

FENDT

Werkstatthandbuch

Workshopmanual

Manuel d'atelier

Manual de taller

Manuale per l'officina

Werkplaatshandboek

FENDT 900 Vario COM III

X 990.005.057.012

1

FENDT

A	General
B	Faults
C	Documents and Diagrams
D	Component location
E	Testing
F	Setting and Calibration
G	Repair
H	Service – Info

1010

Transmission/differential

FENDT 900 Vario - COM III

Volume 1

0000	Overall system/tractor
1005	Overall system/transmission
1010	Transmission/differential
1015	Transmission/axle drive
1050	Transmission/housing
1070	Transmission / Brake system
1080	Transmission/drive train
1200	Transmission/front PTO
1220	Transmission / Live PTO
1320	Transmission/front wheel drive
2000	Overall system/engine
2010	Engine/cylinder head
2050	Engine/cooling
2060	Engine/fuel system
2210	Engine/crankcase
2312	Engine/lubrication
2400	Engine/exhaust system
2712	Engine/injectors
3000	Overall system/front axle
3120	Front axle/steering cylinder
3180	Front axle/cardan shaft

Volume 2

4000	Overall system/steering
4090	Steering system / hydraulic steering unit
5030	Vehicle layout/operator's seat
5500	Overall system/air conditioning system
8100	Overall system/cab
8610	Power lift/EPC electro-hydraulic control
8631	Power lift/hydraulic lift
8800	Overall system/compressed air system

Volume 3

9000	Overall system/electrical system
9015	Electrical system/starter lockout

FENDT 900 Vario - COM III

Volume 4

9410	Hydraulic pump installation/LS pump
9430	Hydraulic pump installation/steering pump
9534	Hydraulic piping/"Rüfa"reverse operation
9600	Overall system/hydraulic equipment
9605	Hydraulic equipment/hydraulic connections
9610	Hydraulic equipment/central control block (ZSB)
9620	Hydraulic equipment/valve fitting
9700	Overall system/electronics
9920	Service/special tools
9975	Service/SERDIA - Deutz engine diagnostics program

1010 Transmission/differential

G **Repair.5**

G Repair

1	Remove differential gear	7
2	Installing the differential	11
3	Dismantling differential gear	16
4	Assembling the differential gear	20
5	Dismantling the pinion shaft	25
6	Adjusting and fitting the pinion shaft	28
7	Pinion shaft - ring gear backlash adjustment	34

1 Remove differential gear

Preliminary work:

– see §1

NOTE: The work was carried out on a model for greater clarity.

Carry out the following tasks on both sides.

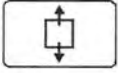

Unscrew the hand brake release screw on the Tristop cylinder by turning counterclockwise until it becomes noticeably more difficult to turn, then tighten as far as it will go with a spanner (SW24)

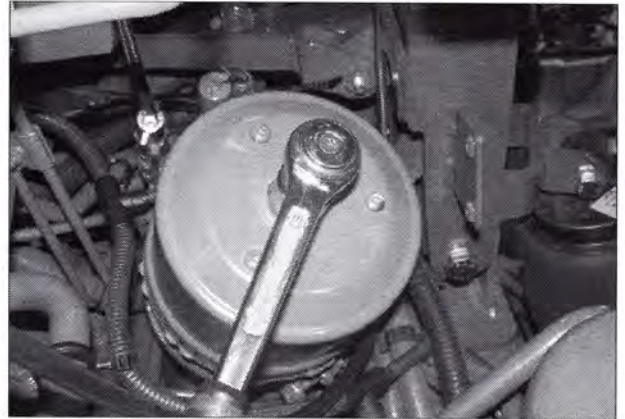
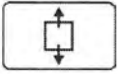

Fig. 1.

1002468



Unplug the air hoses and sensors



Fig. 2.

1002469

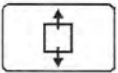

Remove Tristop cylinder

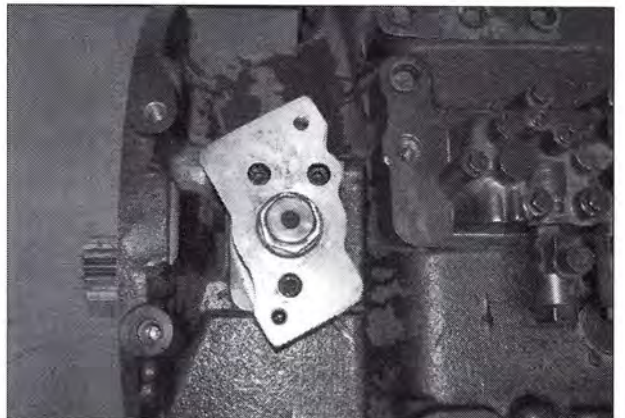
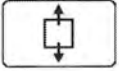

Fig. 3.

1010439



Remove lower part of brake cylinder

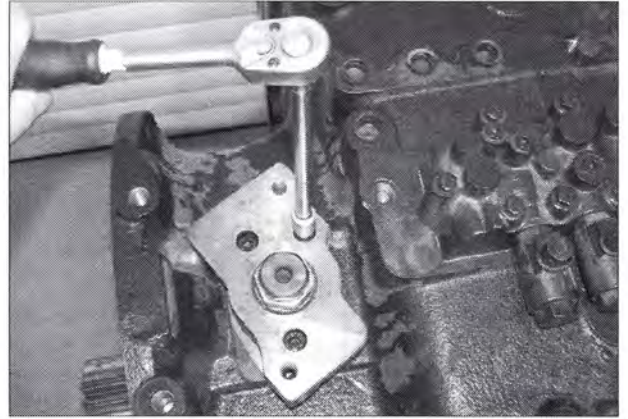
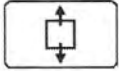

Fig. 4.

1010440



Remove brake plate hex bolts

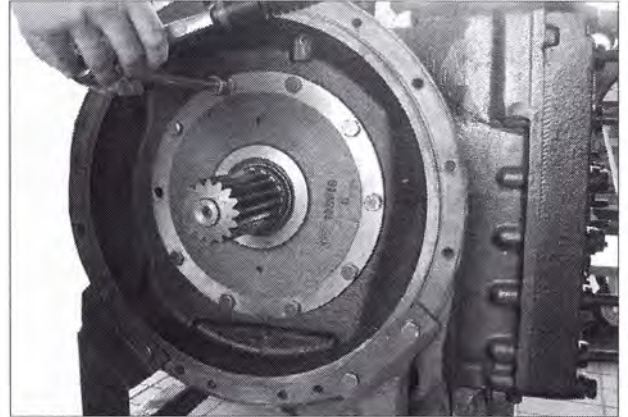
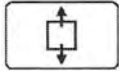

Fig. 5.

1002637



Remove brake plate using a slide hammer puller

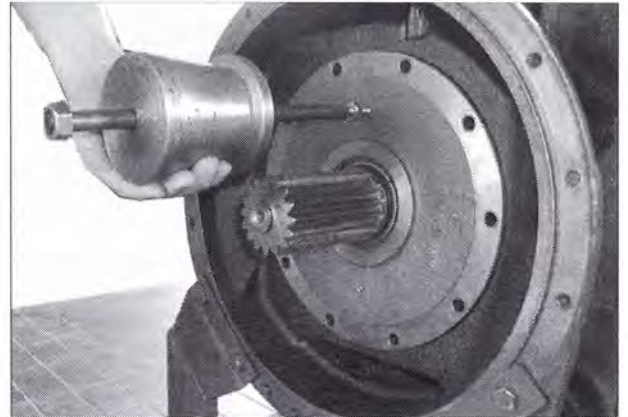
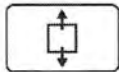

Fig. 6.

1002638



Remove brake plate

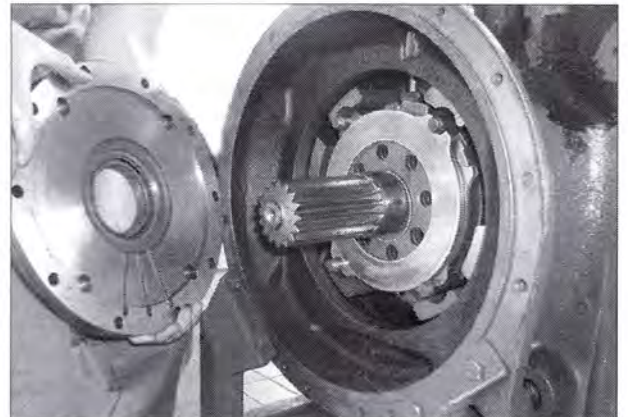
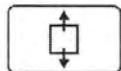

Fig. 7.

1002639



Remove shaft



Fig. 8.

I002643

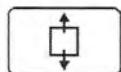

Remove front disc pack

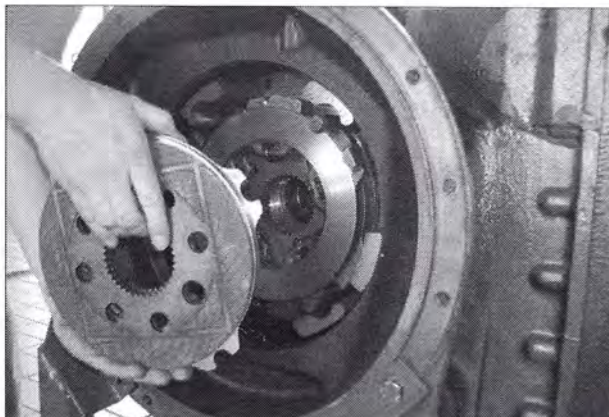
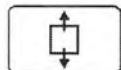

Fig. 9.

I002644



Remove actuator plate and rear disc pack

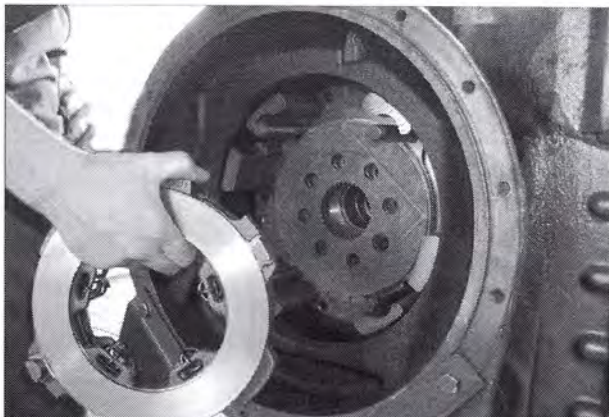
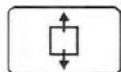

Fig. 10.

I002645



Attach hoisting gear to differential gear

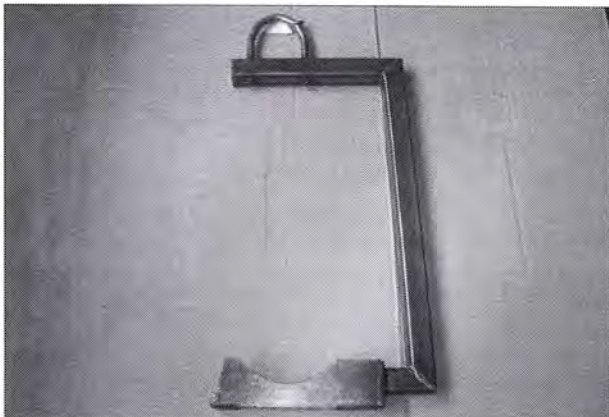

Fig. 11.

I002649

919 .. 0101-1000
 919 .. 1001-
 922 .. 0101-1000
 922 .. 1001-
 925 .. 0101-1000

925 .. 1001-
 928 .. 0101-1000
 928 .. 1001-
 931 .. 0101-1000
 931 .. 1001-

934 .. 0101-1000
 934 .. 1001-

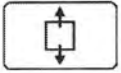

Press off bearing flange with jack screws

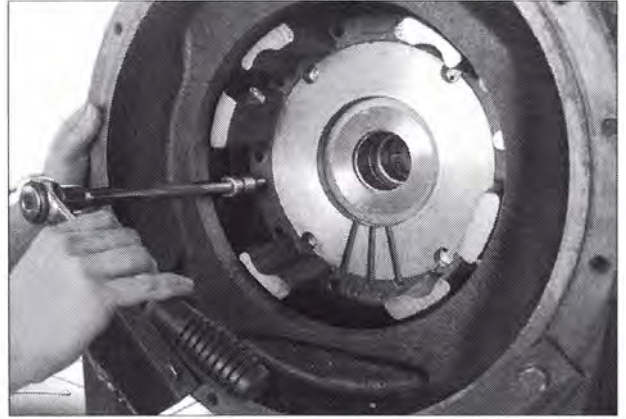
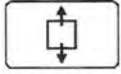

Fig. 12.

I002646



Remove bearing flange

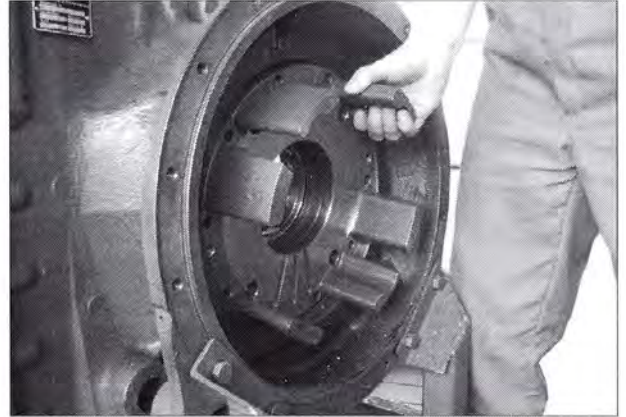
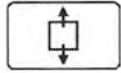

Fig. 13.

I002647



Remove differential gear using the hoisting gear

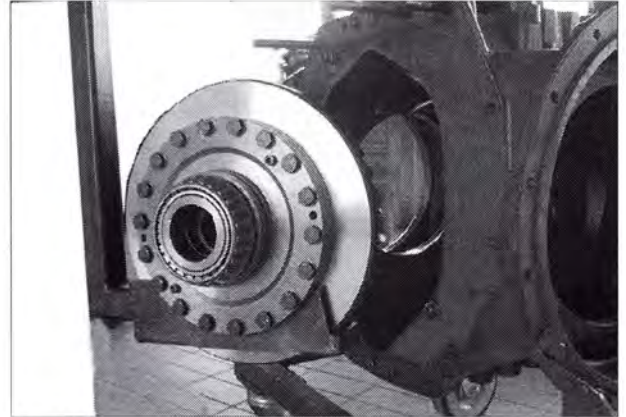
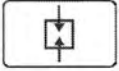

Fig. 14.

I002648

2 Installing the differential

NOTE: The work was carried out on a model for greater clarity.



Fit the differential in the transmission housing using the hoisting gear



Fig. 15.

I002668

The following tasks must be carried out on both sides. Starting on the right side.

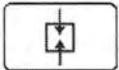

Fit stud bolts (M12x180) as a mounting aid

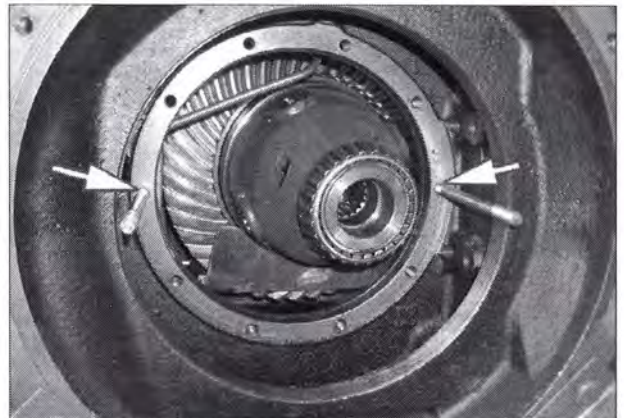
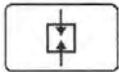

Fig. 16.

I002674



Push the bearing flange on to the stud bolts. Fit the bolts for the externally toothed discs

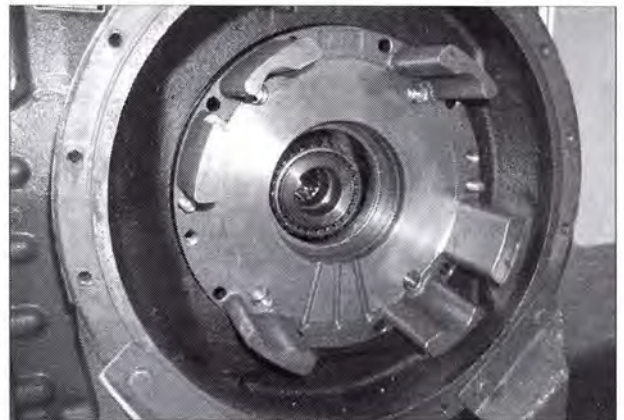
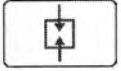

Fig. 17.

I002675



Fit the spacer

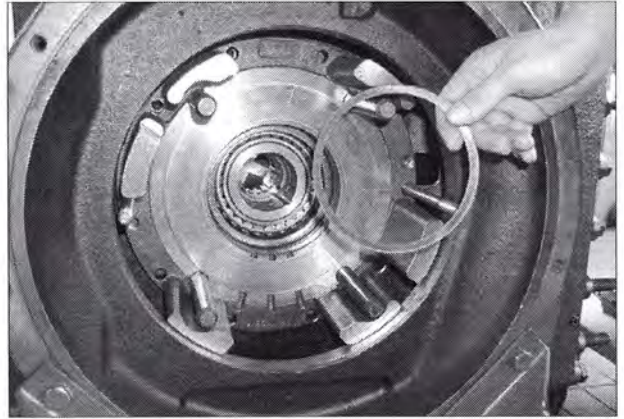
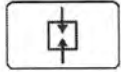

Fig. 18.

1002676



Fit the thrust ring with collar facing inwards

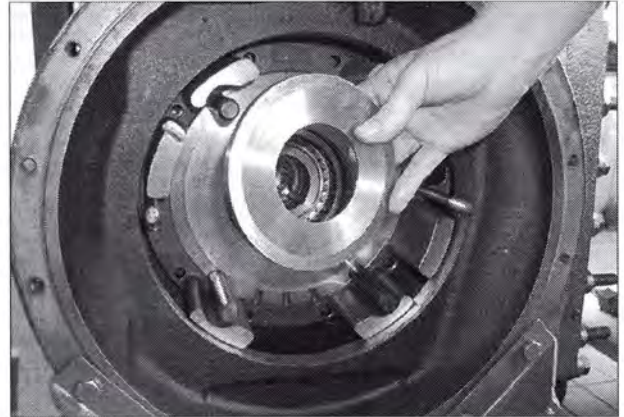
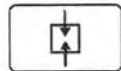

Fig. 19.

1002677



Fit the circlip

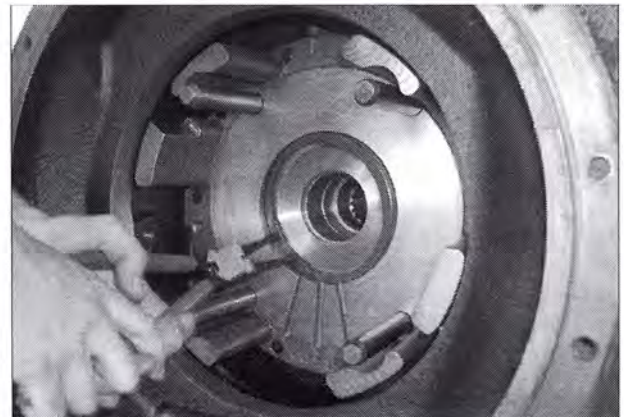
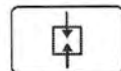

Fig. 20.

1002686



Fit 3 pairs of discs. Starting with the externally toothed discs

NOTE: Fit the externally toothed discs 90° offset to each other

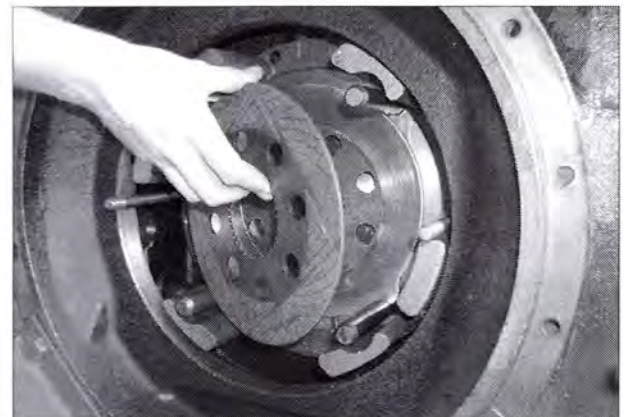
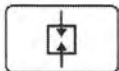

Fig. 21.

1002678



Fit the actuator plate

NOTE: Attach the 3rd and 4th externally toothed discs to the actuator plate

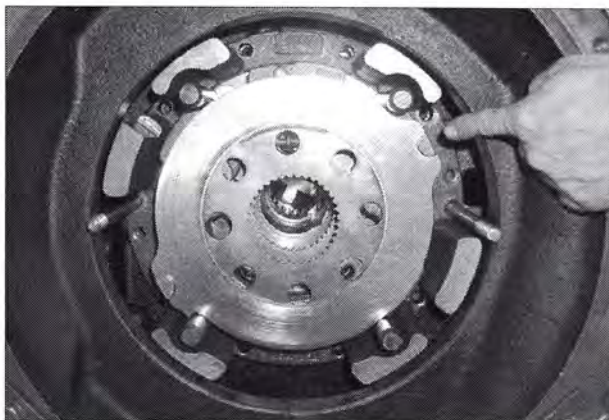
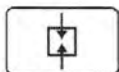

Fig. 22.

1002679



Fit remaining discs and thread in wheel axle

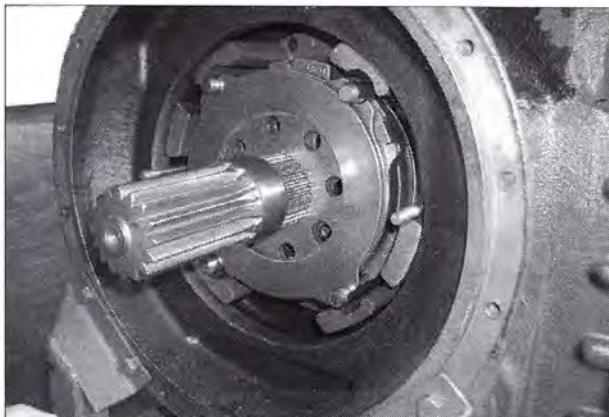
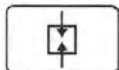

Fig. 23.

1002680



Fit brake plate with new shaft seal ring

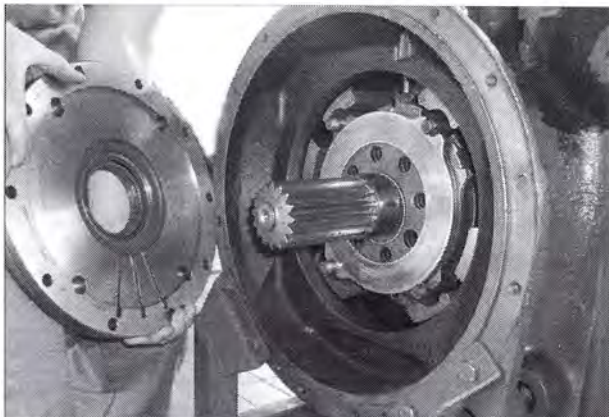
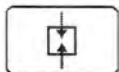

Fig. 24.

1002639



Tighten the brake plate hex bolts crosswise, while constantly checking the clearance of the differential, attach brake plate to system

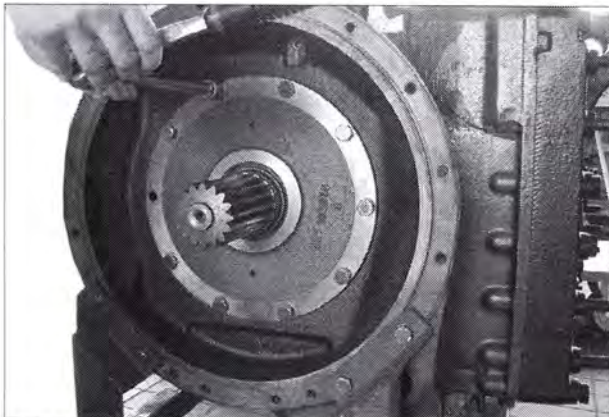

Fig. 25.

1002637

919 .. 0101-1000
919 .. 1001-
922 .. 0101-1000
922 .. 1001-
925 .. 0101-1000

925 .. 1001-
928 .. 0101-1000
928 .. 1001-
931 .. 0101-1000
931 .. 1001-

934 .. 0101-1000
934 .. 1001-

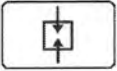

Using a rotating device and torque gauge, check the roll resistance to be 4–6Nm. If necessary, use an adjusting shim



Fig. 26.

1002735

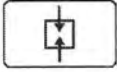

Tighten hex bolts to 120 Nm

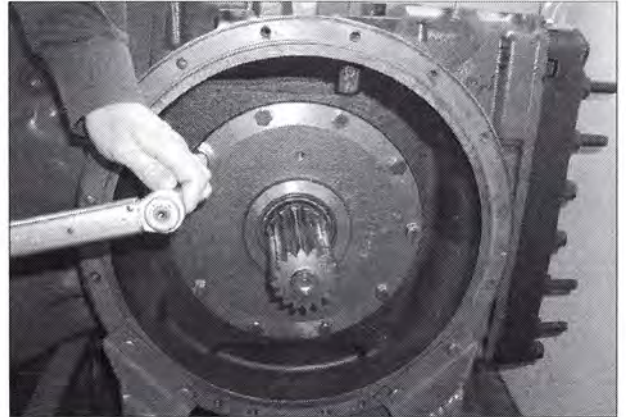
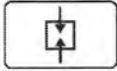

Fig. 27.

1002685



Fit lower part of brake cylinder
Tightening torque for bolts: 69 Nm

NOTE: Adjust the rear wheel brake
see §1

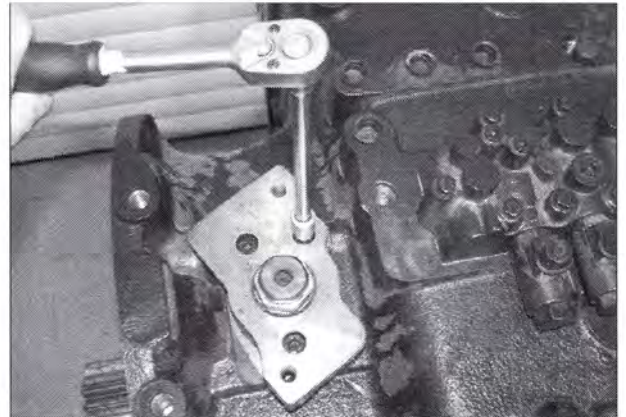
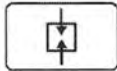

Fig. 28.

1010440



Fit Tristop cylinder with flat seal
Bolt tightening torque: 86 Nm

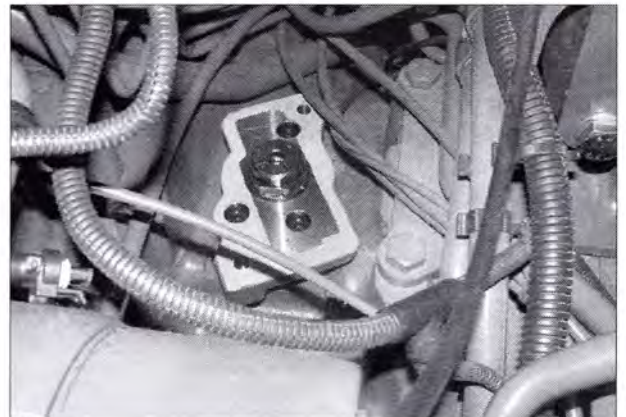
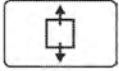

Fig. 29.

1002477



Connect air hoses and sensors



Fig. 30.

I002469

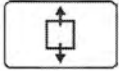

Screw in the hand brake release screw on the Tristop cylinder in a clockwise direction

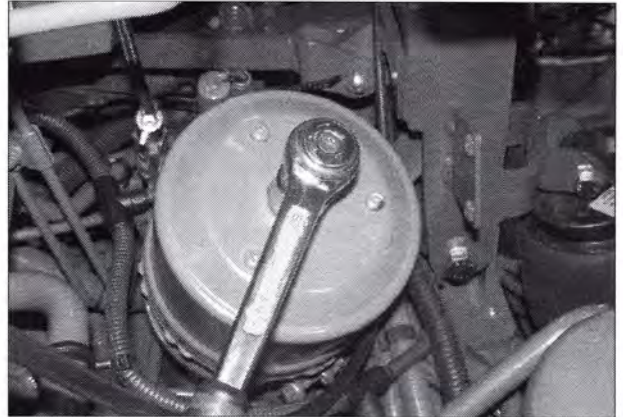

Fig. 31.

I002468

3 Dismantling differential gear

Preliminary work:

- see §1

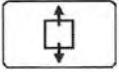

Loosen hex bolts

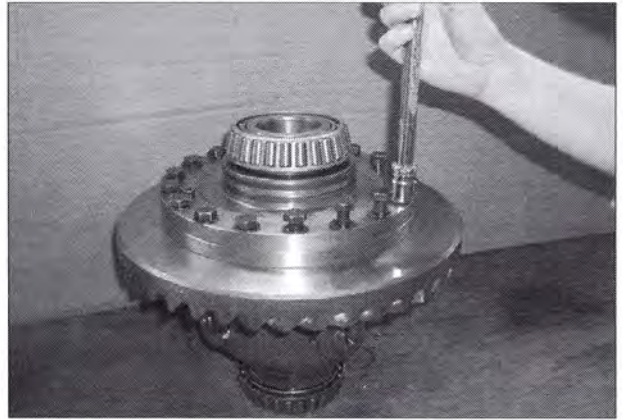
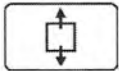

Fig. 32.

I002650



Loosen hex socket head screws

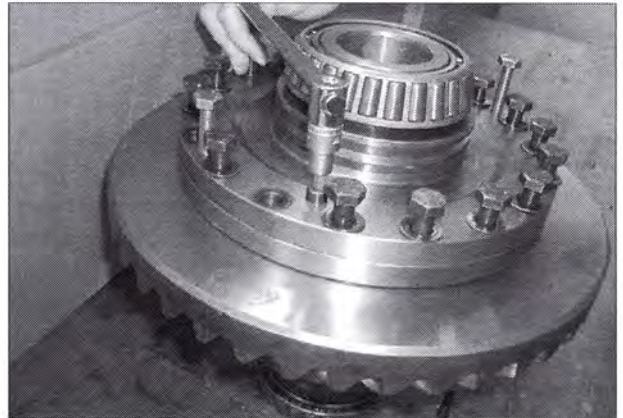
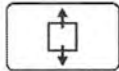

Fig. 33.

I002651



Press off the housing flange

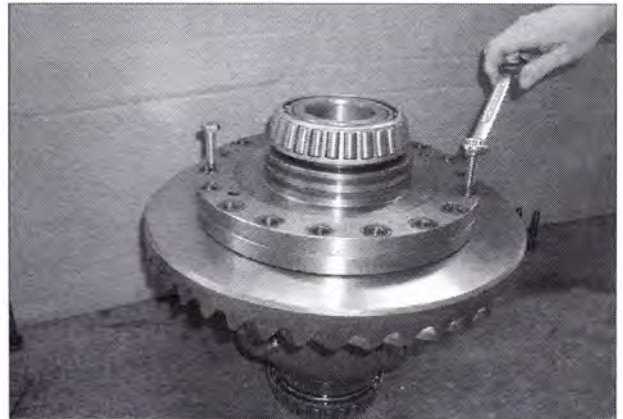
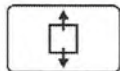

Fig. 34.

I002652



Remove the housing flange



Fig. 35.

I002653

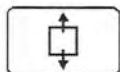

Remove the disc package with axle bevel gear

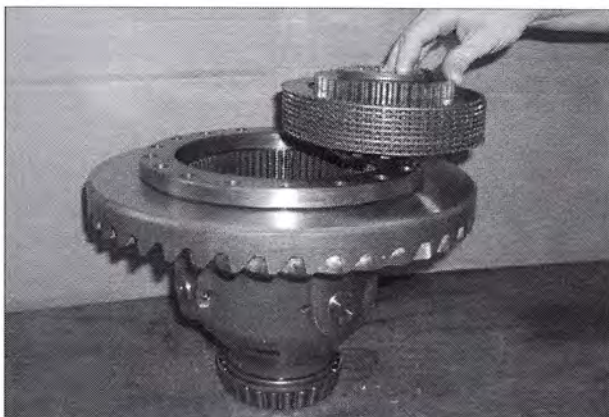
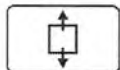

Fig. 36.

I002654



Remove the ring gear



Fig. 37.

I002655

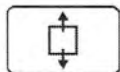

Remove the shaft hollow dowel pins

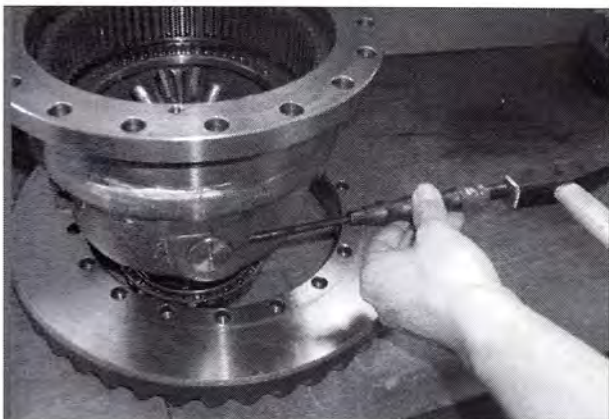

Fig. 38.

I002656

919 .. 0101-1000
919 .. 1001-
922 .. 0101-1000
922 .. 1001-
925 .. 0101-1000

925 .. 1001-
928 .. 0101-1000
928 .. 1001-
931 .. 0101-1000
931 .. 1001-

934 .. 0101-1000
934 .. 1001-

T000821
Version 1
07-11-2007

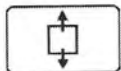

Remove the long shaft

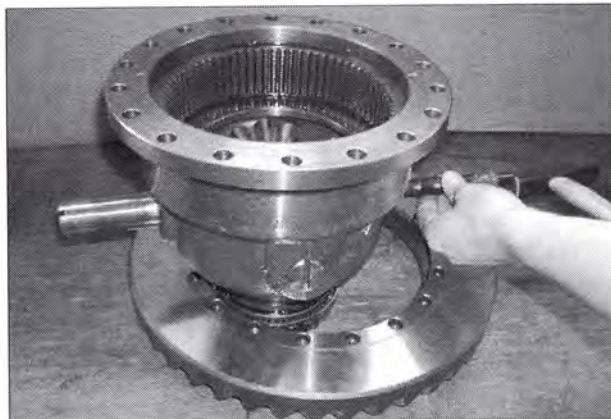
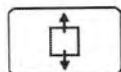

Fig. 39.

1002657



Remove the short shaft



Fig. 40.

1002658

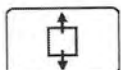

Remove the cross bearing

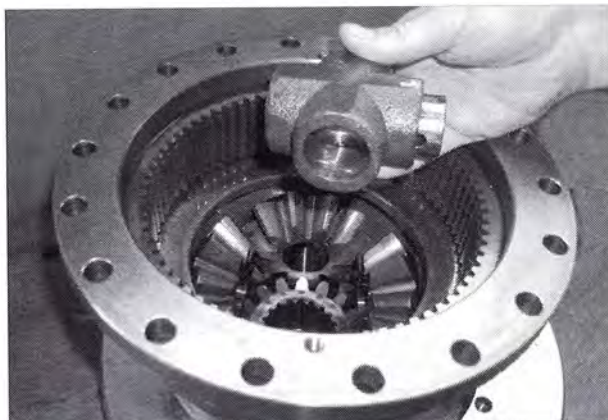
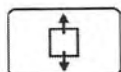

Fig. 41.

1002659



Remove the pinion gears and thrust rings

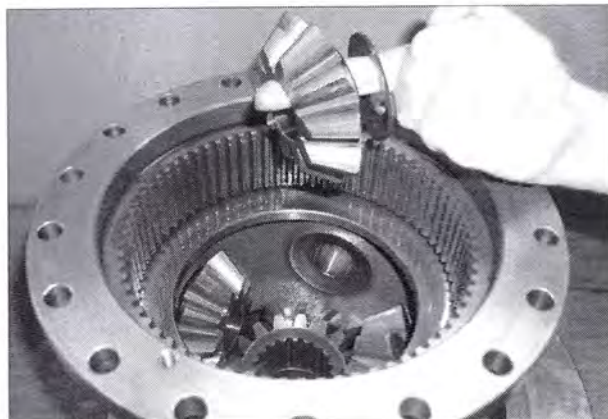
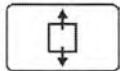

Fig. 42.

1002660



Remove the axle bevel gear

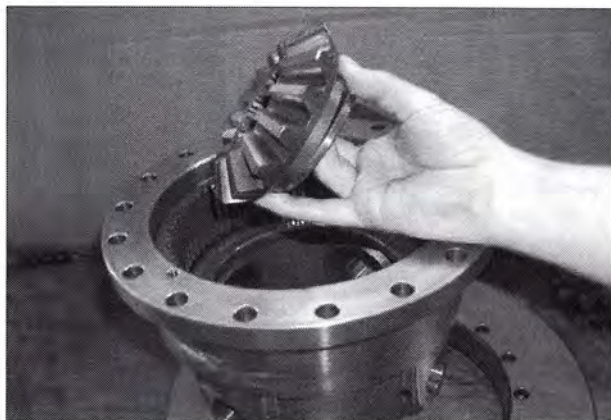
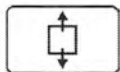

Fig. 43.

I002661



Remove the ring disk

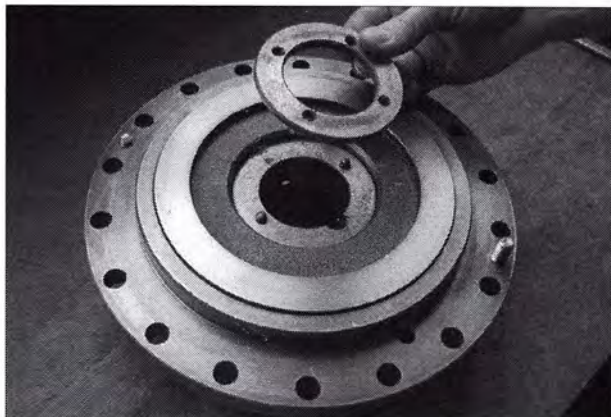
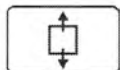

Fig. 44.

I002662



Remove the piston from the housing flange



Fig. 45.

I002663

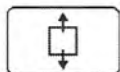

Remove the taper roller bearing

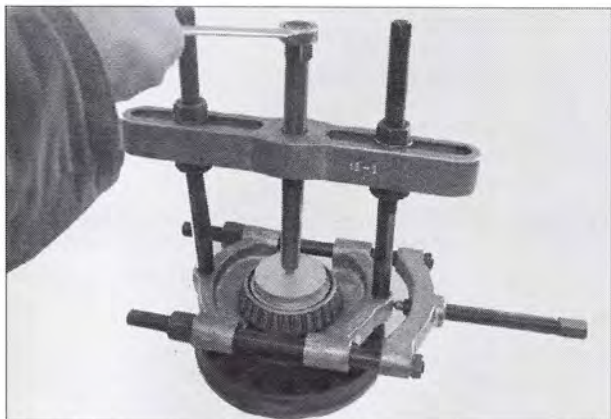

Fig. 46.

I002669

919 .. 0101-1000
919 .. 1001-
922 .. 0101-1000
922 .. 1001-
925 .. 0101-1000

925 .. 1001-
928 .. 0101-1000
928 .. 1001-
931 .. 0101-1000
931 .. 1001-

934 .. 0101-1000
934 .. 1001-

T000821
Version 1
07-11-2007

4 Assembling the differential gear

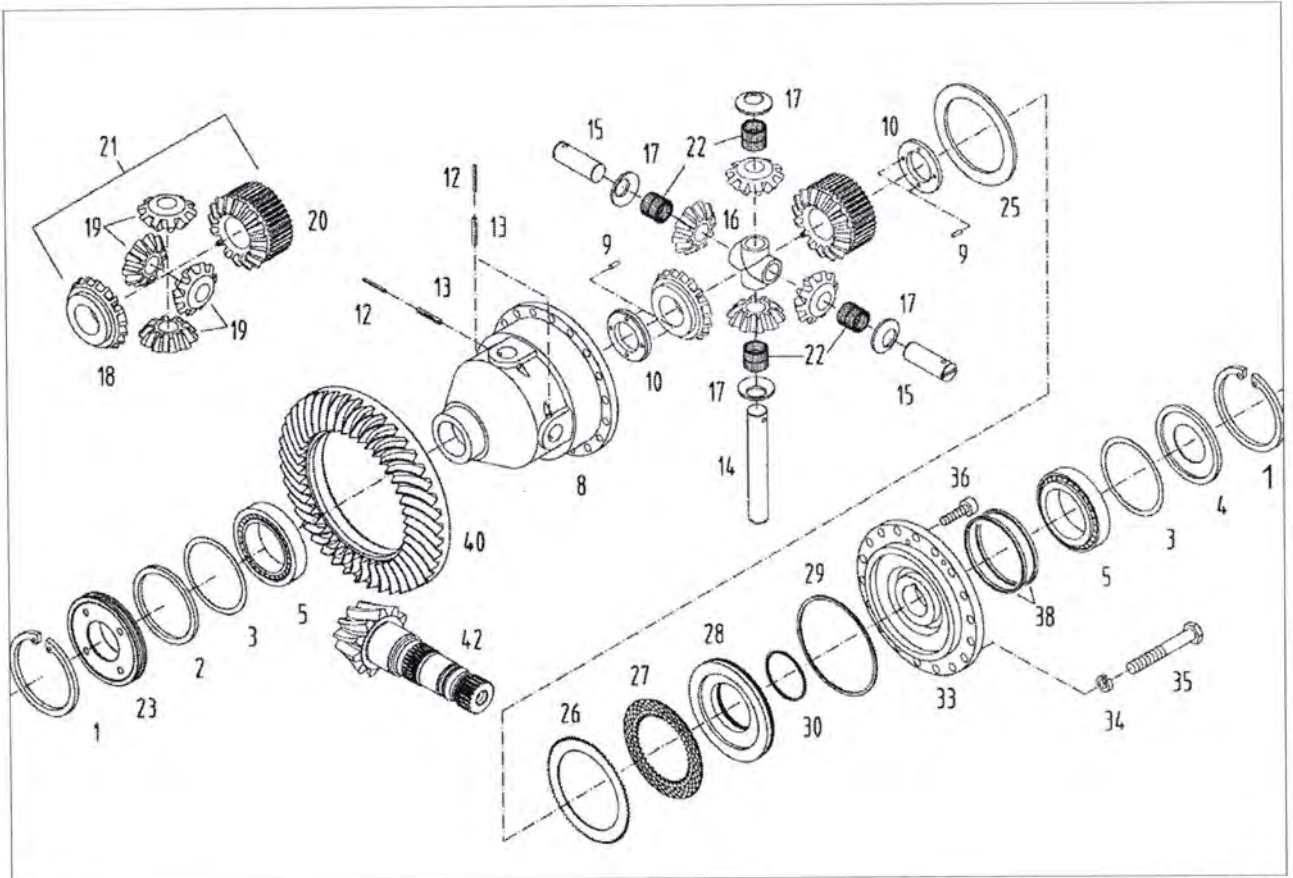
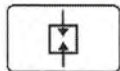

Fig. 47.

1002670

1	Circlip	21	Bevel gear set
3	Shim	22	Cylinder roller bearing
4	Washer	23	Spacer
5	Taper roller bearing	25	Ring
8	Differential housing	26	External disc
9	Parallel pin	27	Internal disc
10	Ring	28	Piston
12	Dowel pin	29	Lip seal
13	Dowel pin	30	Lip seal
14	Axle	33	Housing flange
15	Axle	34	Washer
16	Cross bearing	35	Hex. bolt
17	Thrust ring	36	Socket head cap screw
18	Axle bevel gear	38	Rectangular-section ring
19	Differential bevel gears	40	Ring gear
20	Axle bevel gear	42	Pinion shaft



Heat the taper roller bearing (5) to approx. 90°C and fit it onto the housing flange (33) and differential housing (8)

CAUTION: Risk of burns!



Fig. 48.

I002673

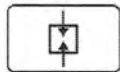

Fit the piston (28) with new lip sealing rings (29, 30) into the housing flange (33)

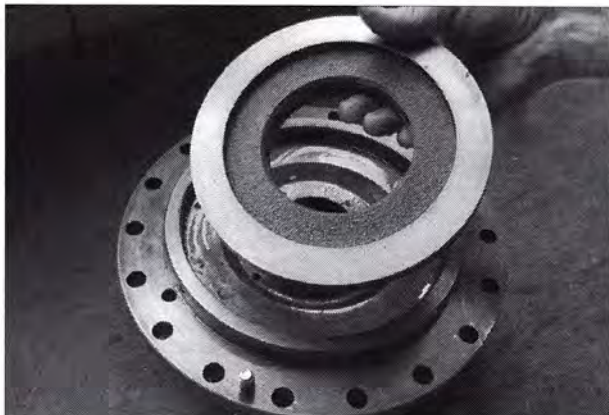
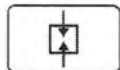

Fig. 49.

I002663



Fit the ring (10) with the coated side upwards into the housing flange (33); coat the underside of the ring with heavy grease to prevent it falling out

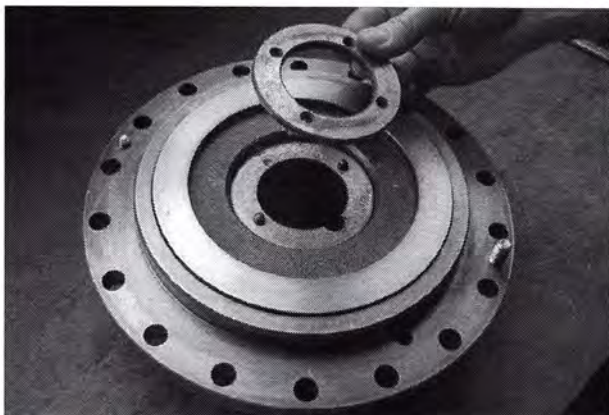
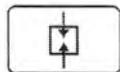

Fig. 50.

I002662



Fit the ring (10) with the coated side upwards into the differential housing (8)

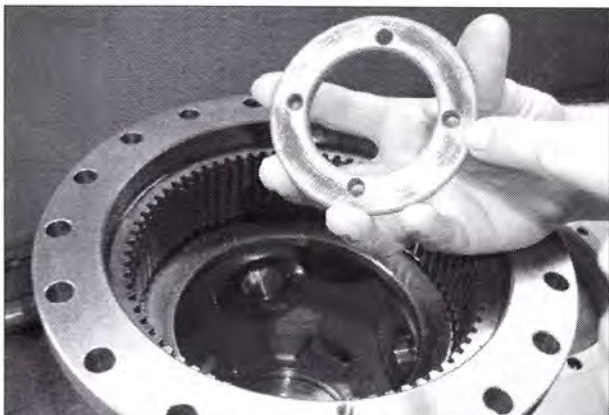

Fig. 51.

I002671

919 .. 0101-1000
919 .. 1001-
922 .. 0101-1000
922 .. 1001-
925 .. 0101-1000

925 .. 1001-
928 .. 0101-1000
928 .. 1001-
931 .. 0101-1000
931 .. 1001-

934 .. 0101-1000
934 .. 1001-

T000822
Version 1
07-11-2007

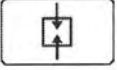

Lay the axle bevel gear (18) in the differential housing (8)

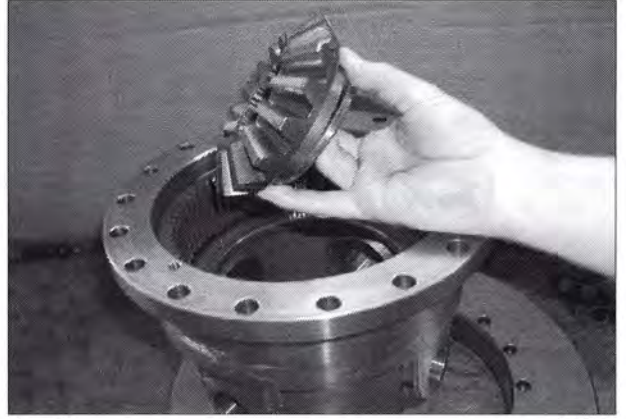
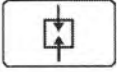

Fig. 52.

1002661



Fit the cylinder roller ring (22) into the differential bevel gears

NOTE: *Emplace the cylinder rollers with heavy grease*

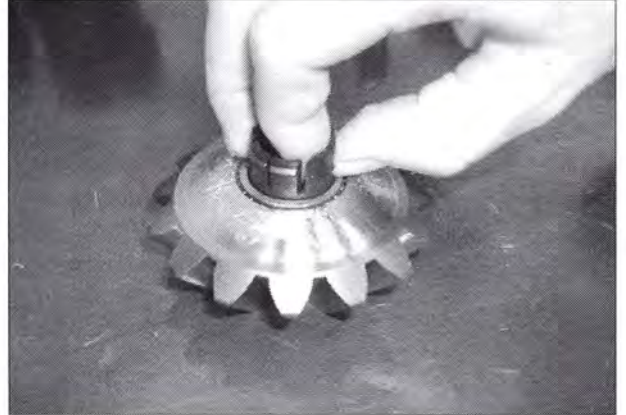
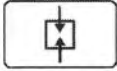

Fig. 53.

1002672



Fit the differential bevel gears (19) with the thrust ring (17)

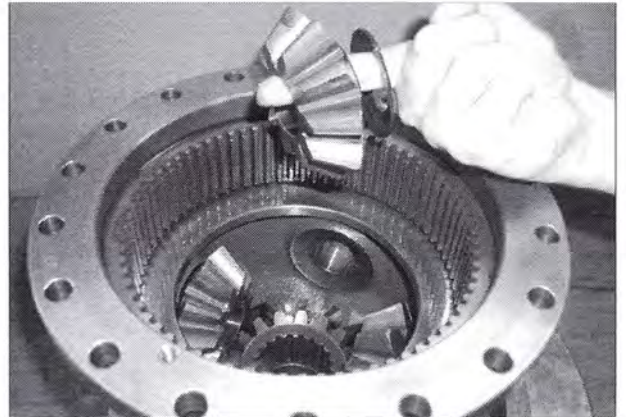
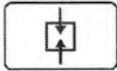

Fig. 54.

1002660



Fit the cross bearing (16)

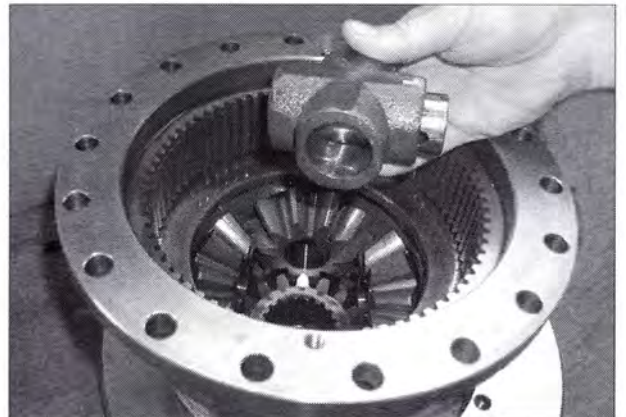
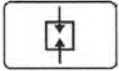

Fig. 55.

1002659



Fit the long axle (14) and then the two short axles (15) and secure the axles (14, 15) with the dowel pins (12, 13)

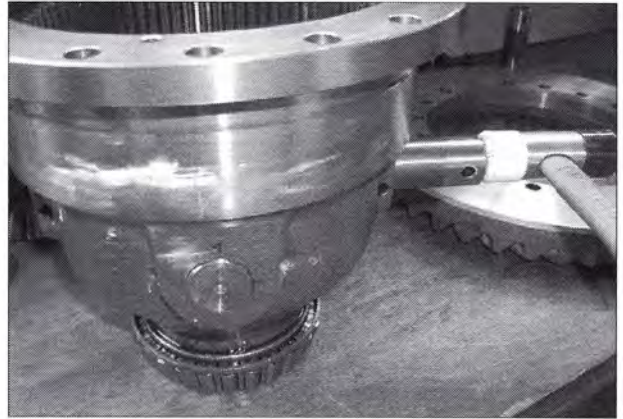
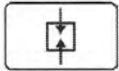

Fig. 56.

1002664



Fit the axle bevel gear (20)

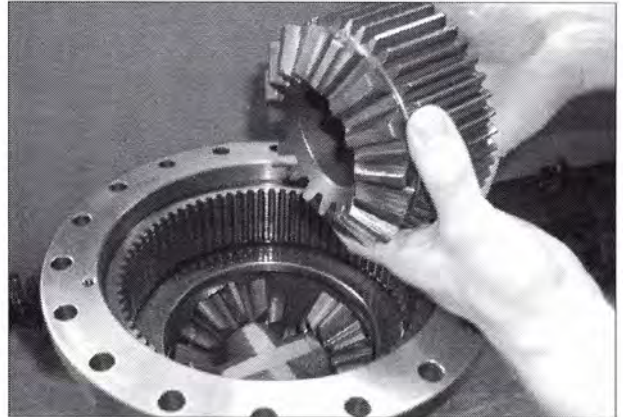
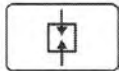

Fig. 57.

1002665



Fit the ring (25) along with the outer and inner discs (26, 27)

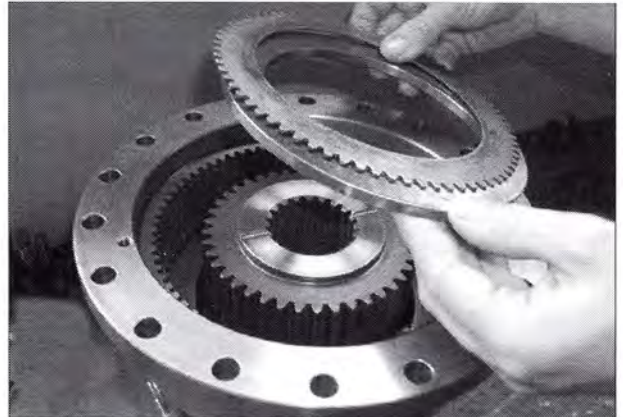
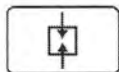

Fig. 58.

1002666



Fit the housing flange (33) to the differential housing (8)

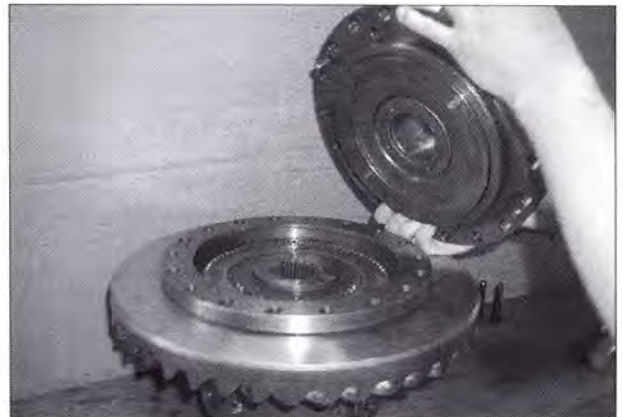

Fig. 59.

1002653

919 .. 0101-1000
919 .. 1001-
922 .. 0101-1000
922 .. 1001-
925 .. 0101-1000

925 .. 1001-
928 .. 0101-1000
928 .. 1001-
931 .. 0101-1000
931 .. 1001-

934 .. 0101-1000
934 .. 1001-

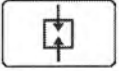

Fit the hex. bolts (35) and the two hex. socket head bolts (36)

Torque value for the hex. bolt (35): 120 Nm

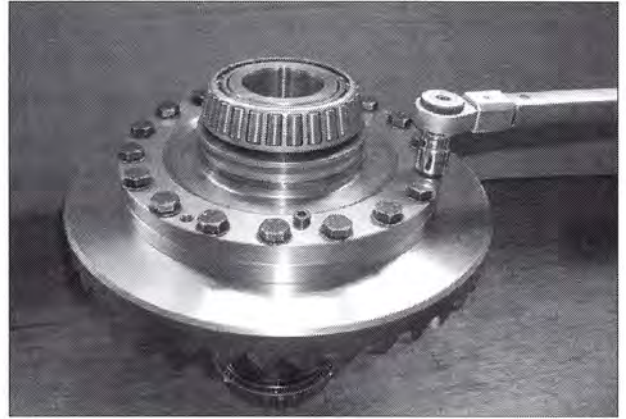
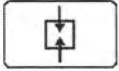

Fig. 60.

1002667



Fit the rectangular-section rings (38)

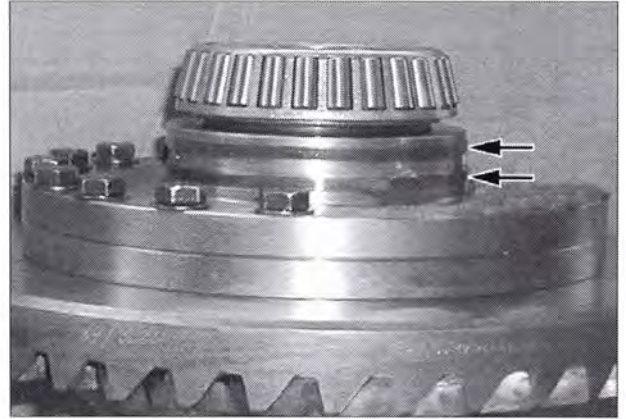

Fig. 61.

1002734

5 Dismantling the pinion shaft

Preliminary work:

- see §1
- Separate the rear axle from the transmission housing

NOTE: The work was carried out on a model for greater clarity.

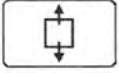

Remove the pinion shaft lubricating line

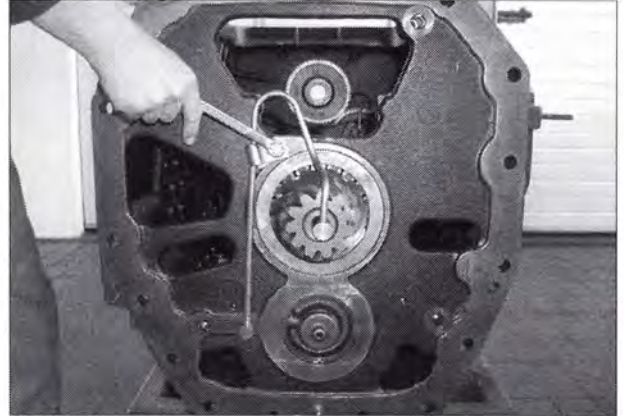
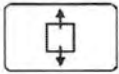

Fig. 62.

1002688



Remove the inner securing ring as well as the spacers

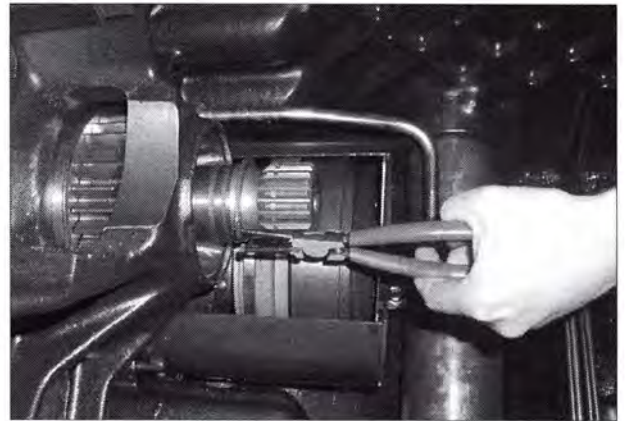
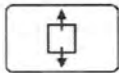

Fig. 63.

1002700



Place a hydraulic jack between the bevel pinion shaft and the supporting frame (self-made) and push out the pinion shaft



Fig. 64.

1002690

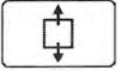

Remove the pinion shaft

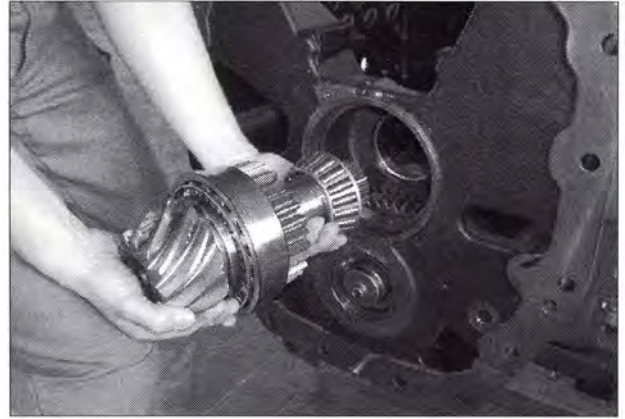
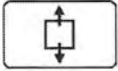

Fig. 65.

1002691



Remove the bevel roller bearings from the pinion shaft



Fig. 66.

1002712

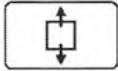

Remove the securing ring and toothed gear

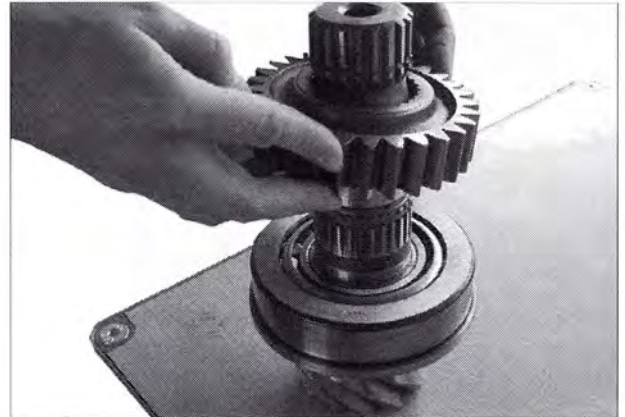
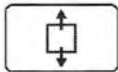

Fig. 67.

1002692



Remove the bevel roller bearing



Fig. 68.

1002693

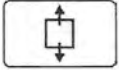

Remove the adjustment spacer



Fig. 69.

I002689

919 .. 0101-1000
919 .. 1001-
922 .. 0101-1000
922 .. 1001-
925 .. 0101-1000

925 .. 1001-
928 .. 0101-1000
928 .. 1001-
931 .. 0101-1000
931 .. 1001-

934 .. 0101-1000
934 .. 1001-

T000824
Version 1
07-11-2007

6 Adjusting and fitting the pinion shaft

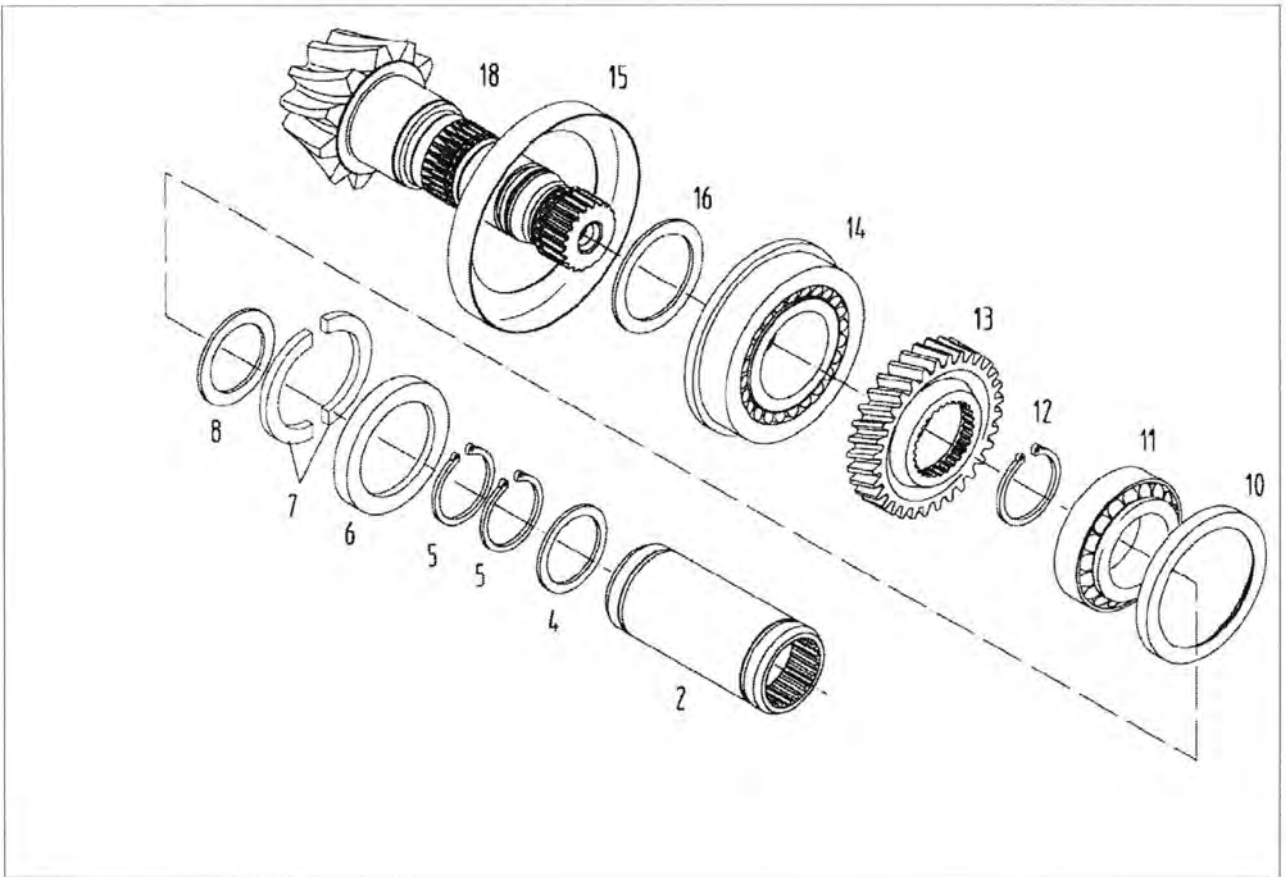

Fig. 70.

1002713

2	Spigot bush	12	Circlip
4	Locating ring	13	Spur gear
5	Circlip	14	Taper roller bearing
6	Ring	15	Oil tray
7	Ring	16	Shim pack
8	Shim pack	18	Pinion shaft
10	Oil tray	19	Ring gear
11	Taper roller bearing		

NOTE: The work was carried out on a model for greater clarity.

Adjusting the pinion shaft

Determining the spacer thickness S (16):

Calculated spacer thickness $S_{\text{target}} = G + A - E - F$

Chosen spacer thickness $S_{\text{actual}} = S_{\text{target}} - 0.04 \text{ mm}$

- G = Actual dimension middle of rear axle - flange surface (nominal dimension = 190)
- A = Bore depth in transmission housing (nominal dimension = $20^{+0.1}$).
- E = Bearing width (nominal dimension = $20^{+0.2}$).
- F = Actual installation dimension of pinion shaft (nominal dimension = 187)

Determining dimension A:

Determine bore depth from outer flange face.

Nominal dimension = $20^{+0.1}$



Fig. 71.

1002694

Determining dimension E:

Carefully roll in the tapered roller bearing before taking the measurement

Carry out the measurement on a level surface (surface plate)

Nominal dimension = $20^{+0.2}$

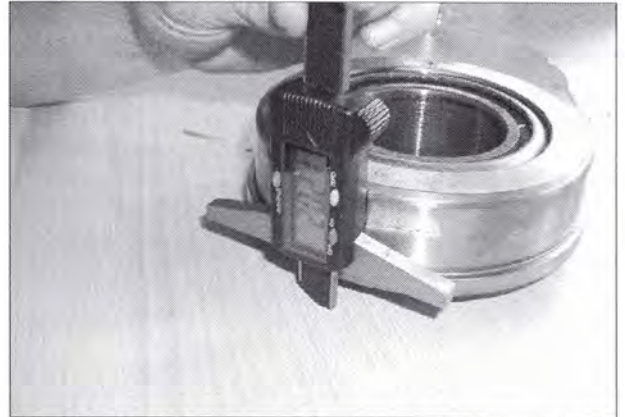

Fig. 72.

1002695

Determining dimension F:

The installation dimension is engraved on the front end of the pinion shaft

Nominal dimension = 187



Fig. 73.

1002696

The actual dimension is engraved on the flange surface of the rear axle housing

Nominal dimension = 190



Fig. 74.

1002707

Spacer thickness (16) $S = G + A - E - F$	
Dimension G =	190.02
Dimension A =	20.03
Dimension E =	20.2
Dimension F =	187.00
S =	2.85



Fig. 75.

1002689

Fitting the pinion shaft

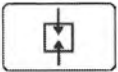

Fit a spacer of the determined thickness onto the pinion shaft

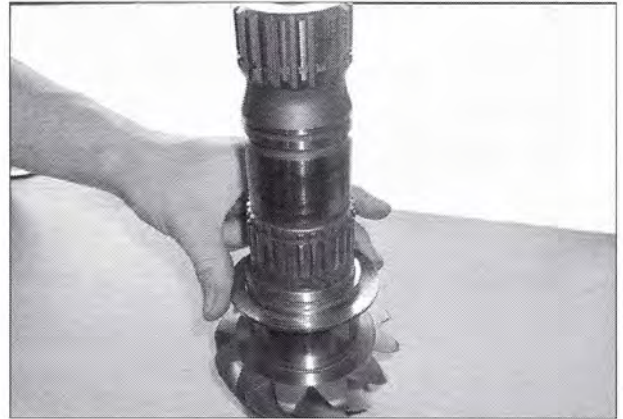
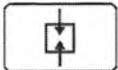

Fig. 76.

1002689



Heat the taper roller bearing (14) to approx. 90°C and fit it to the pinion shaft



CAUTION: Risk of burns!

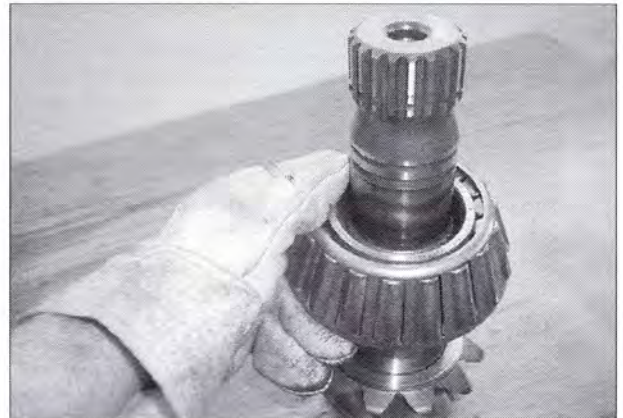
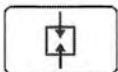

Fig. 77.

1002714



Emplace the spur gear (13) in the transmission housing



Fig. 78.

1002715

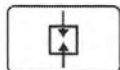

Press the oiled bearing outer ring of the taper roller bearing (14) into the transmission housing as far as it will go

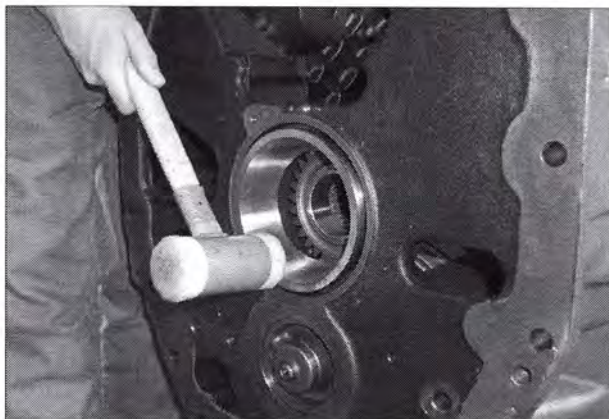
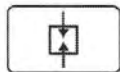

Fig. 79.

1002697



Press the oiled bearing outer ring of the taper roller bearing (11) into the transmission housing as far as it will go

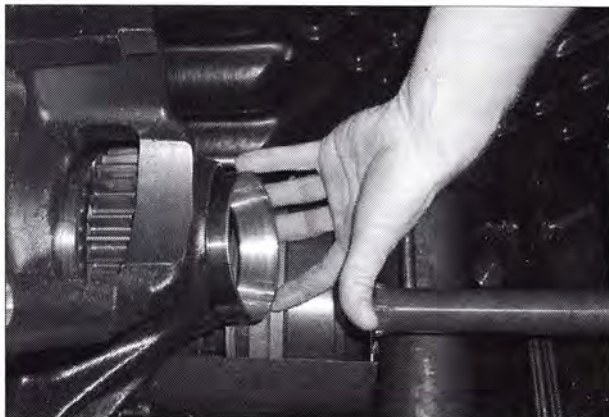
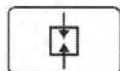

Fig. 80.

1002698



Oil the taper roller bearing (14) and insert the pre-assembled pinion shaft into the transmission housing; thread the constant 4WD (spur gear) at the same time

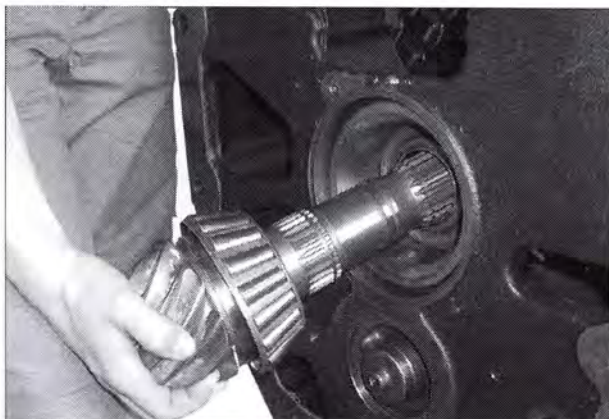
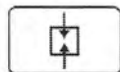

Fig. 81.

1002699



Fit the circlip (12)

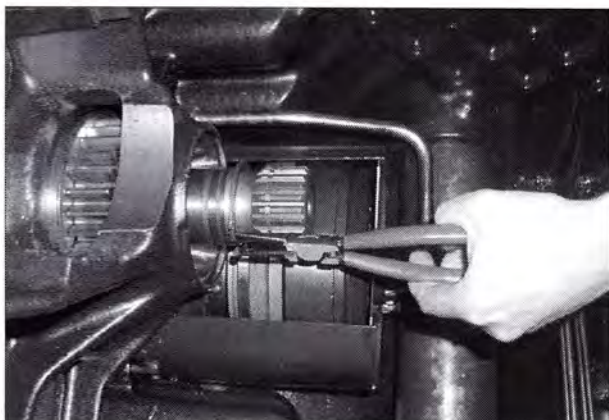

Fig. 82.

1002700

919 .. 0101-1000
919 .. 1001-
922 .. 0101-1000
922 .. 1001-
925 .. 0101-1000

925 .. 1001-
928 .. 0101-1000
928 .. 1001-
931 .. 0101-1000
931 .. 1001-

934 .. 0101-1000
934 .. 1001-

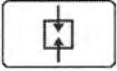

Heat the taper roller bearing (11) to approx. 90°C and fit it to the pinion shaft, liberally oil the taper roller bearing



CAUTION: Risk of burns!

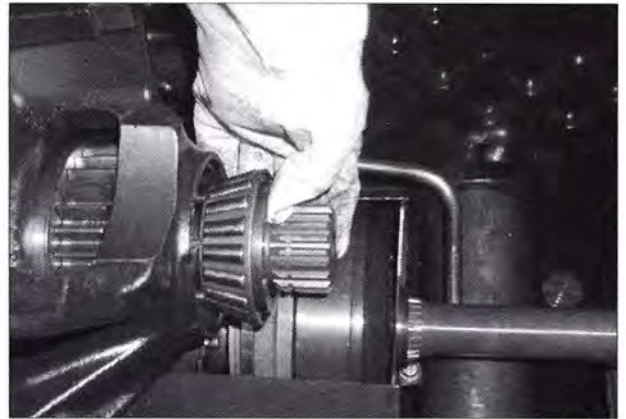
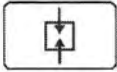

Fig. 83.

1002701



Pre-tension the bearing with a drawing tool and threaded spindle

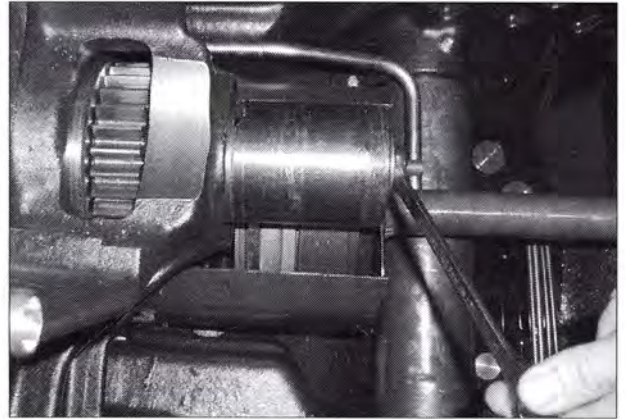
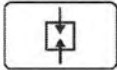

Fig. 84.

1002702



Using a rotating device and torque gauge, check the roll resistance to be 2-6 Nm, adjust using a shim pack (8)

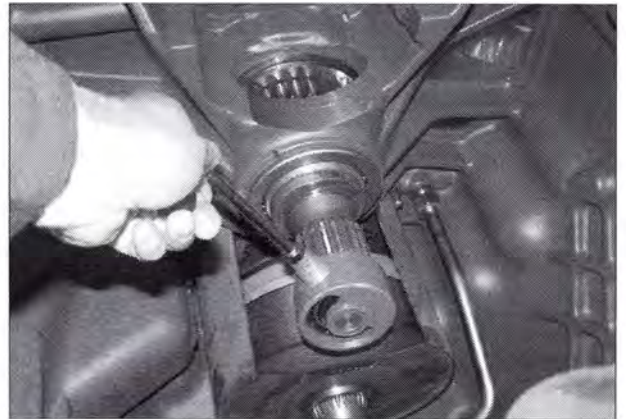
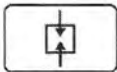

Fig. 85.

1002736



Fit rings (6, 7) onto the pinion shaft (18)

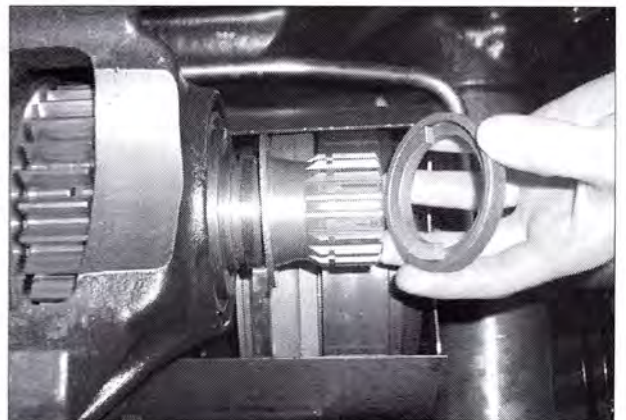
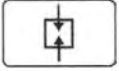

Fig. 86.

1002704



Fit the circlip (5)

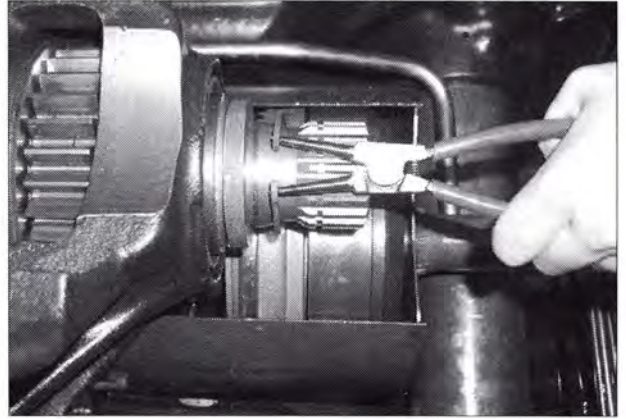
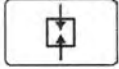

Fig. 87.

1002705



Fit the oil trays (10, 15)

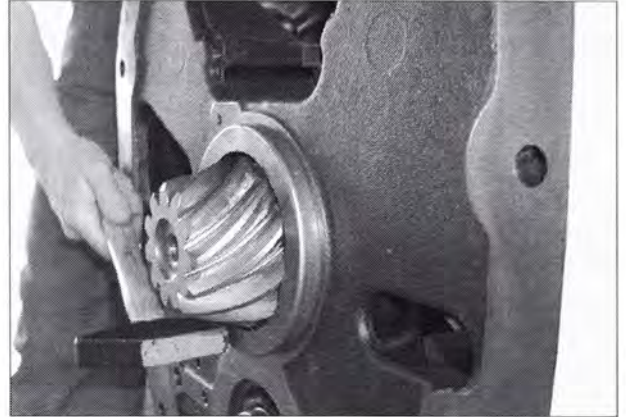

Fig. 88.

1002706

7 Pinion shaft - ring gear backlash adjustment

Backlash adjustment calculation:

Calculation: Target dimension A = X - E - 0.2 mm

- X = Actual dimension, middle of pinion shaft to measurement surface of the rear axle housing (156)
- E = Adjustment dimension engraved on the ring gear
- 0.2 mm = Tooth play

Target dimension A = X - E - 0.2 mm	
Dimension X =	156.03
Dimension E =	81.01
Tooth play =	0.2
Specified dimension A =	74.82

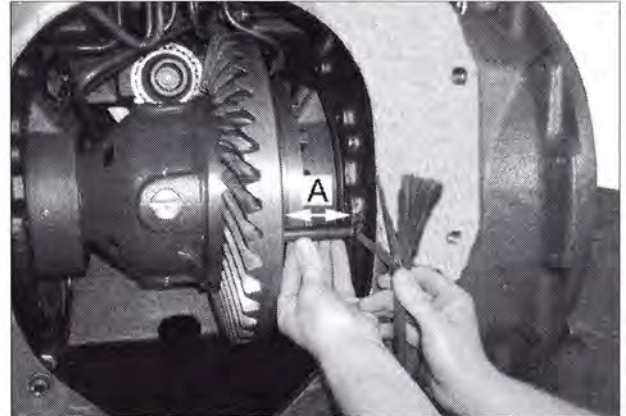

Fig. 89.

1002716

Determining dimension X

The actual dimension is engraved on the flange surface of the rear axle housing



Fig. 90.

1002707

NOTE: Using a gauge block of 74.00 mm (self-made) and a feeler gauge, determine dimension A. If there is a variation from the target dimension, adjust the dimension by changing the shim (tolerance $+0.05$).

If dimension A is not correct, change the shims

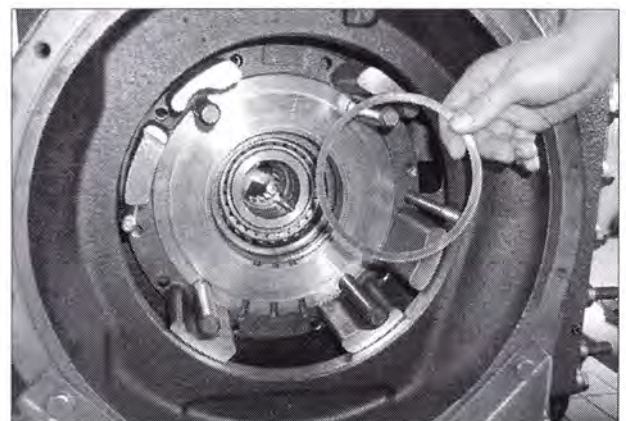

Fig. 91.

1002676

Checking the wear pattern

Coat the sides of six to eight of the ring gear teeth with gear marking compound

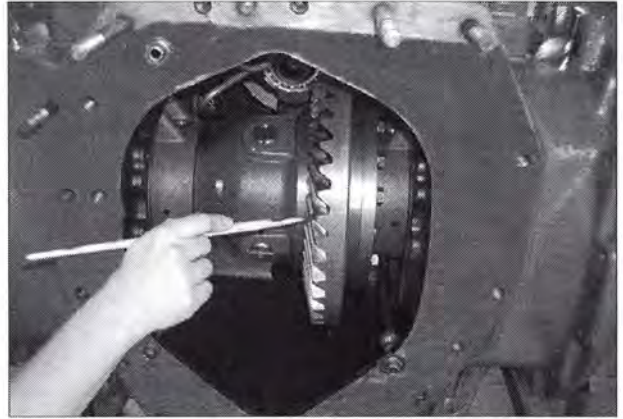

Fig. 92.

1002682

Clean the sealing surfaces, apply sealing compound X903.050.074.000, mate the rear axle housing and the transmission housing, and screw together

Tightening torque: **295 Nm** for M16

Tightening torque: **580 Nm** for M20

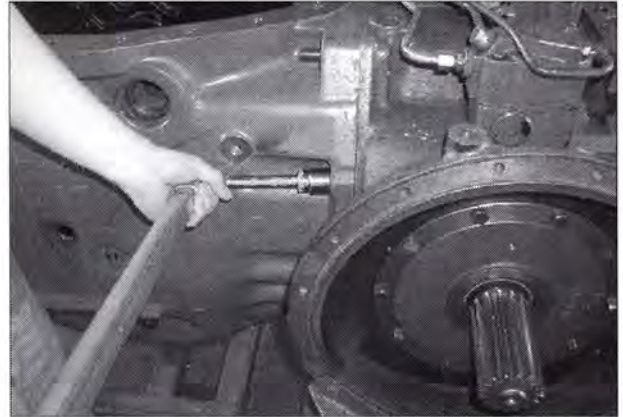

Fig. 93.

1002683

Screw bolt M16 into the pinion shaft and lock it. Rotate the ring gear using the pinion shaft several times in both directions

Check the ring gear and pinion shaft wear pattern through the opening in the housing.

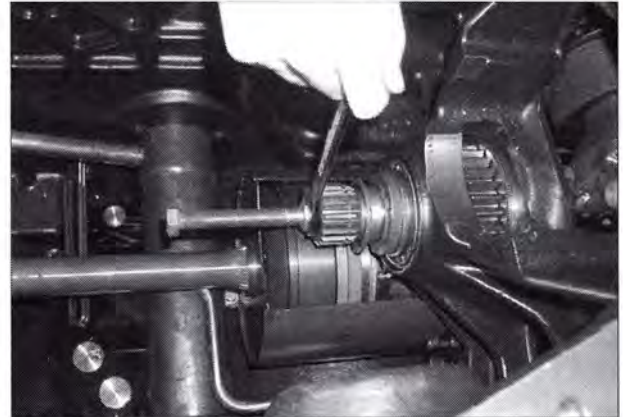

Fig. 94.

1002684

Correct wear pattern for Gleason tothing:

A = Ring gear flank (pull)

B = Ring gear flank (push)

If the wear pattern is wrong, correct the pinion shaft distance accordingly

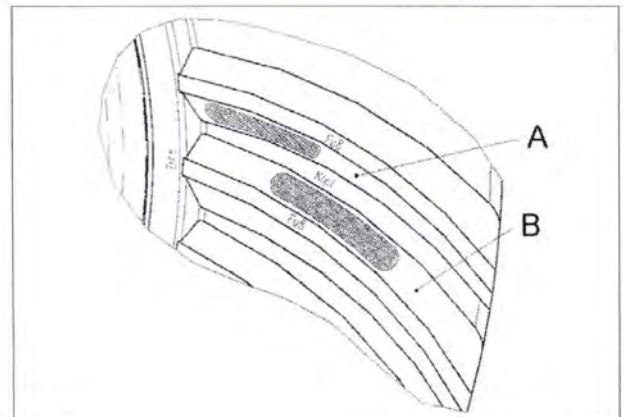

Fig. 95.

1002718

919 .. 0101-1000	925 .. 1001-	934 .. 0101-1000
919 .. 1001-	928 .. 0101-1000	934 .. 1001-
922 .. 0101-1000	928 .. 1001-	
922 .. 1001-	931 .. 0101-1000	
925 .. 0101-1000	931 .. 1001-	

Screw the measuring device (self-made) into the pinion shaft and fit the measuring scale
 Set the measuring scale 34 mm from the middle of the pinion shaft

Determine backlash in four positions.
Target value = 0.2 mm + 0.05

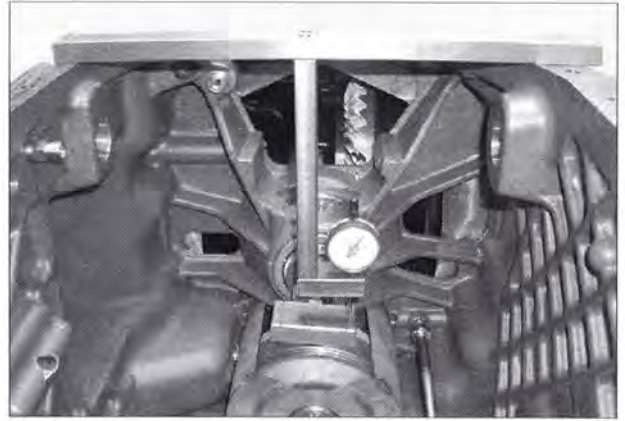

Fig. 96.

I002710