

FENDT

Werkstatthandbuch

Workshopmanual

Manuel d'atelier

Manual de taller

Manuale per l'officina

Werkplaatshandboek

FENDT 900 Vario COM III

X 990.005.057.012

1

FENDT

A	General
B	Faults
C	Documents and Diagrams
D	Component location
E	Testing
F	Setting and Calibration
G	Repair
H	Service – Info

1015

Transmission/axle drive

FENDT 900 Vario - COM III

Volume 1

0000	Overall system/tractor
1005	Overall system/transmission
1010	Transmission/differential
1015	Transmission/axle drive
1050	Transmission/housing
1070	Transmission / Brake system
1080	Transmission/drive train
1200	Transmission/front PTO
1220	Transmission / Live PTO
1320	Transmission/front wheel drive
2000	Overall system/engine
2010	Engine/cylinder head
2050	Engine/cooling
2060	Engine/fuel system
2210	Engine/crankcase
2312	Engine/lubrication
2400	Engine/exhaust system
2712	Engine/injectors
3000	Overall system/front axle
3120	Front axle/steering cylinder
3180	Front axle/cardan shaft

Volume 2

4000	Overall system/steering
4090	Steering system / hydraulic steering unit
5030	Vehicle layout/operator's seat
5500	Overall system/air conditioning system
8100	Overall system/cab
8610	Power lift/EPC electro-hydraulic control
8631	Power lift/hydraulic lift
8800	Overall system/compressed air system

Volume 3

9000	Overall system/electrical system
9015	Electrical system/starter lockout

FENDT 900 Vario - COM III

Volume 4

- 9410** Hydraulic pump installation/LS pump
- 9430** Hydraulic pump installation/steering pump
- 9534** Hydraulic piping/"Rüfa"reverse operation
- 9600** Overall system/hydraulic equipment
- 9605** Hydraulic equipment/hydraulic connections
- 9610** Hydraulic equipment/central control block (ZSB)
- 9620** Hydraulic equipment/valve fitting
- 9700** Overall system/electronics
- 9920** Service/special tools
- 9975** Service/SERDIA - Deutz engine diagnostics program

1015 Transmission/axle drive

G **Repair.5**

G Repair

1 Dismantling and reassembling axle drive 7

1 Dismantling and reassembling axle drive

Technical drawing of axle drive (flange axle)

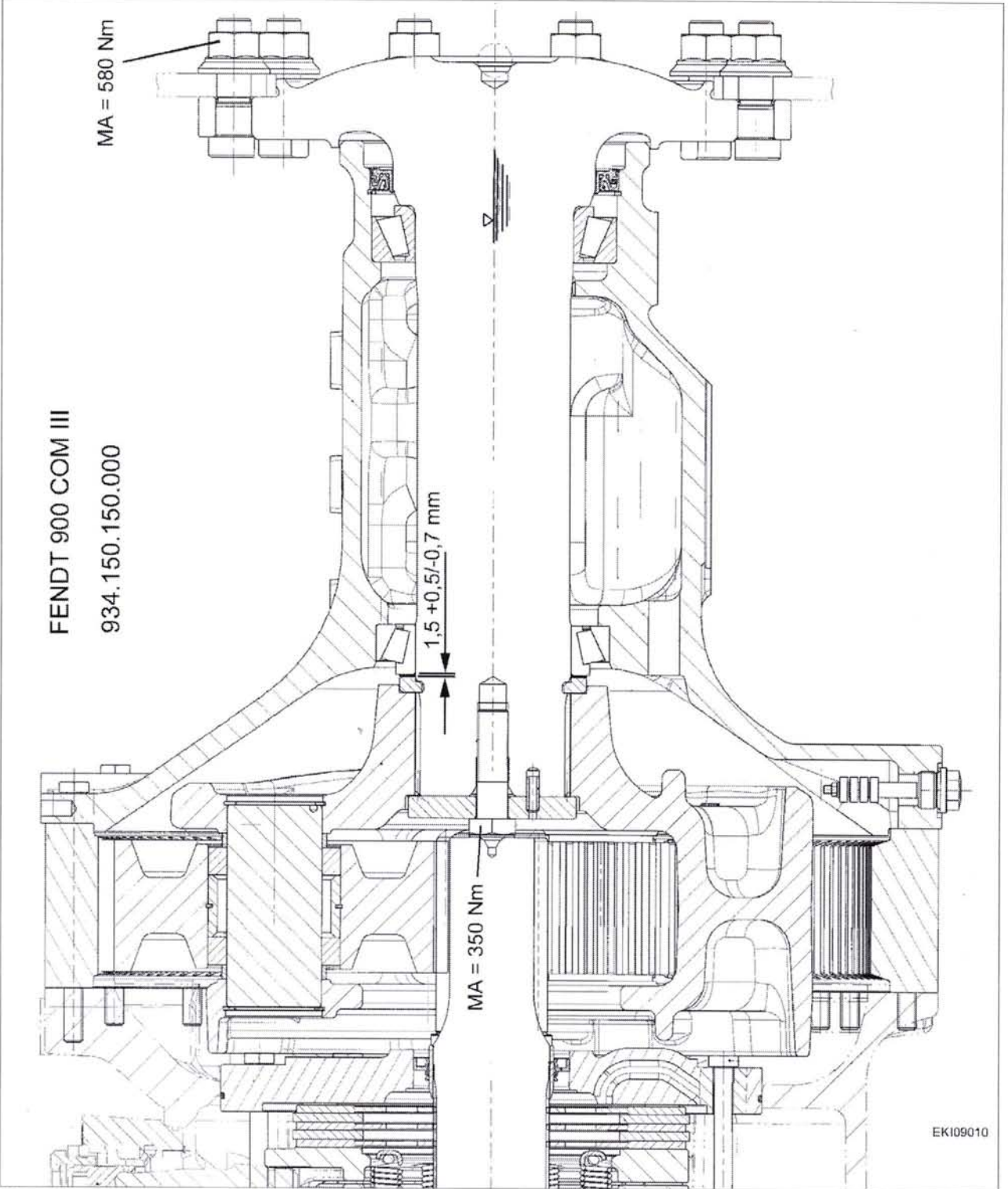

Fig. 1.

1003576

919 .. 0101-1000
 919 .. 1001-
 922 .. 0101-1000
 922 .. 1001-
 925 .. 0101-1000

925 .. 1001-
 928 .. 0101-1000
 928 .. 1001-
 931 .. 0101-1000
 931 .. 1001-

934 .. 0101-1000
 934 .. 1001-

T001212
 Version 1
 07-11-2007

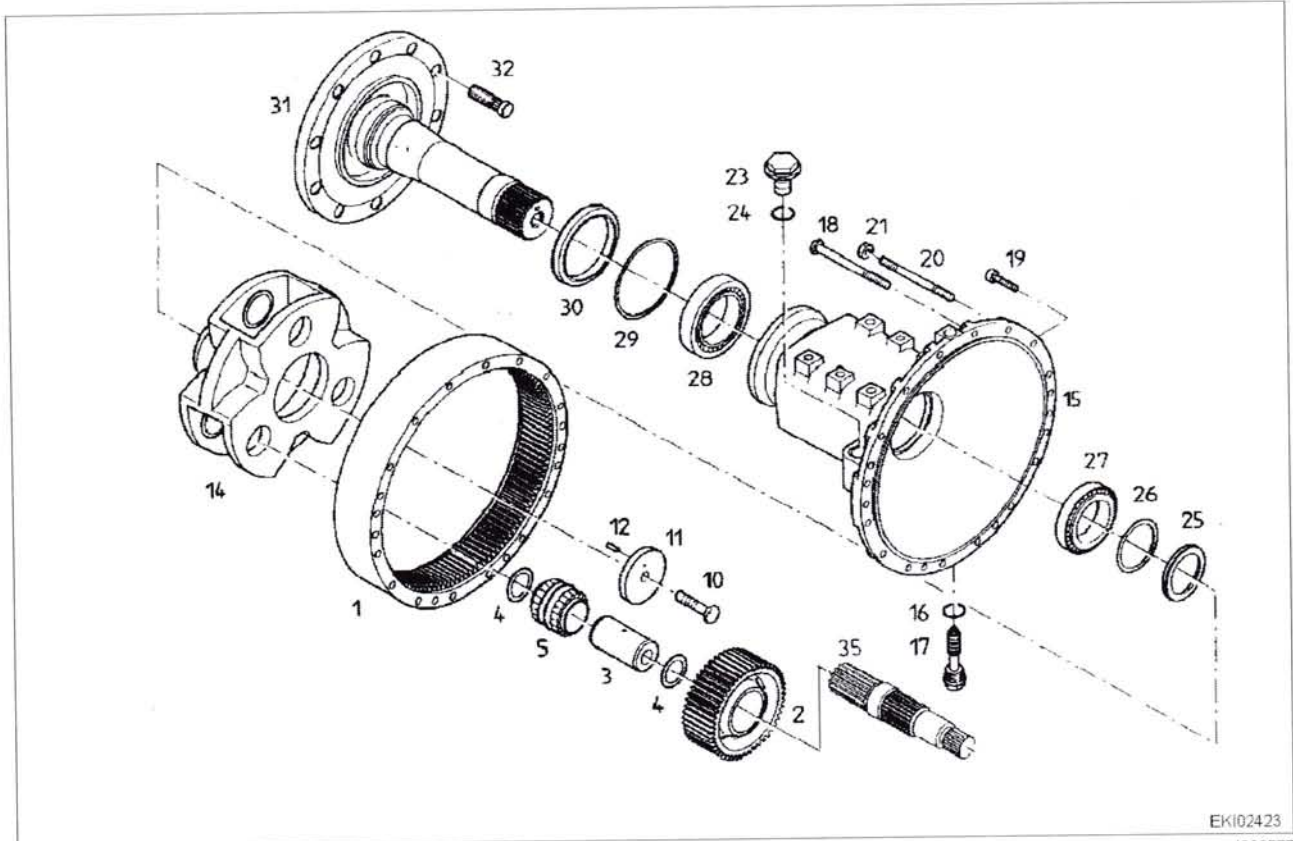

EKI02423

I003577

Fig. 2.

Item	Designation	Item	Designation
1	Internal gear	20	Stud bolt M12 x 165 - 10.9
2	Spur gear	21	Hex. nut M12-10
3	Axle	23	Screw plug M30 x 1.5
4	Circlip	24	Seal ring
5	Cylinder roller ring	25	Ring
10	Hex screw	26	Shim
11	Plate	27	Taper roller bearing
12	Dowel pin	28	Taper roller bearing
14	Planetary carrier	29	Snap ring
15	Axle housing	30	Shaft seal ring
16	Seal ring	31	Rear axle shaft
17	Magnetic plug	32	Wheel bolt
18	Hex. screw M12 x 160-10.9	35	Shaft
19	Socket head cap screw		

Technical drawing of axle drive (stub shaft axle)

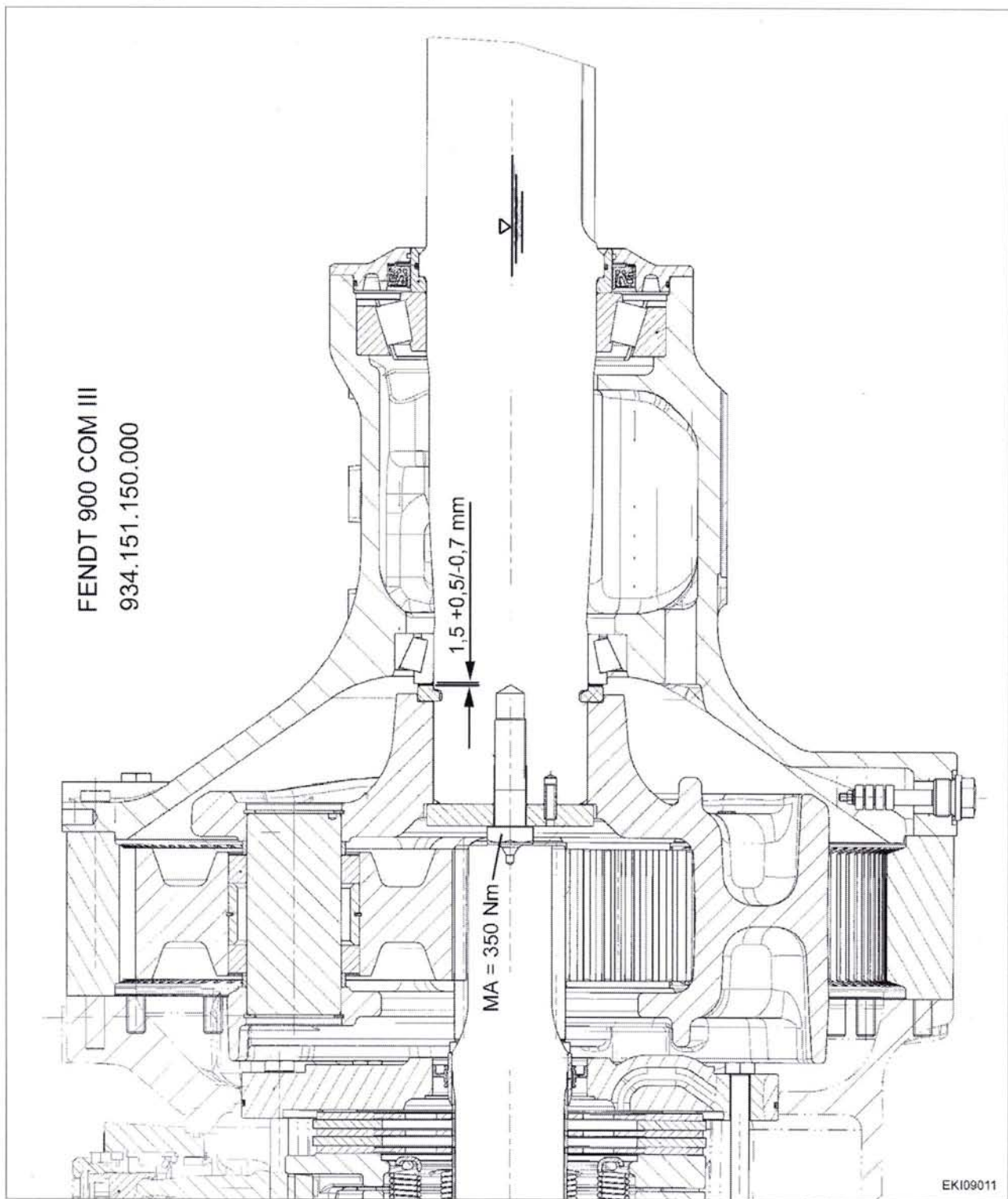

Fig. 3.

919 .. 0101-1000
 919 .. 1001-
 922 .. 0101-1000
 922 .. 1001-
 925 .. 0101-1000

925 .. 1001-
 928 .. 0101-1000
 928 .. 1001-
 931 .. 0101-1000
 931 .. 1001-

934 .. 0101-1000
 934 .. 1001-

T001212
 Version 1
 07-11-2007

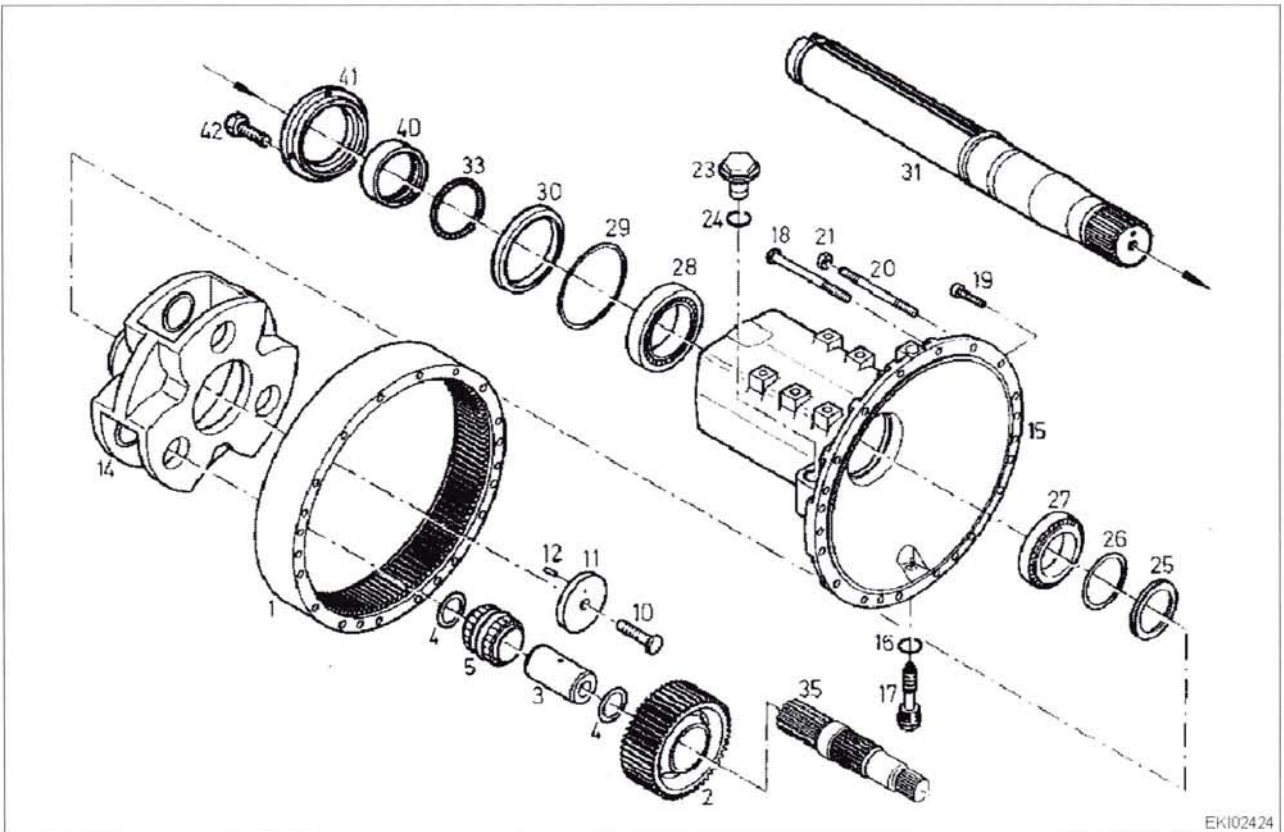

EKI02424

Fig. 4.

I003604

Item	Designation	Item	Designation
1	Internal gear	21	Hex. nut M12-10
2	Spur gear	23	Screw plug M30 x 1.5
3	Axle	24	Seal ring
4	Circlip	25	Ring
5	Cylinder roller ring	26	Shim
10	Hex screw	27	Taper roller bearing
11	Plate	28	Taper roller bearing
12	Dowel pin	29	Snap ring
14	Planetary carrier	30	Shaft seal ring
15	Axle housing	31	Rear axle shaft
16	Seal ring	33	O-ring
17	Magnetic plug	35	Shaft
18	Hex. screw M12 x 160-10.9	40	Spacer
19	Socket head cap screw	41	Cover
20	Stud bolt M12 x 165 - 10.9	42	Hex screw

Dismantling axle drive

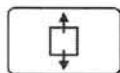

NOTE: The task is carried out on the axle drive (flange).
 Logical repair of axle drive (stub shaft).

Preliminary work:

Remove the axle drive concerned

Screw out socket head cap screws (19) by approx. 10 mm
 and lightly tap the ring gear (1) back

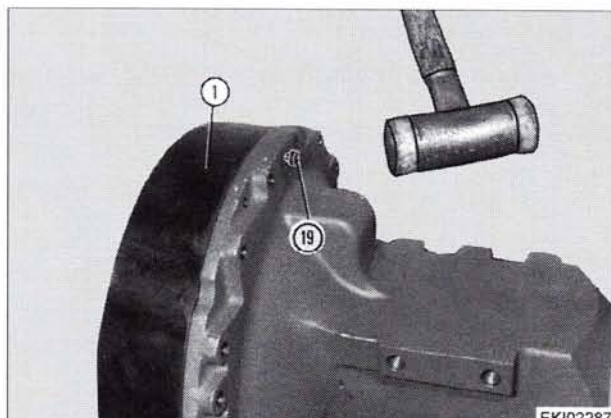
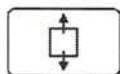

Fig. 5.

EKI02287
 1003605



Screw out the hex screw (10) and remove the planetary carrier

NOTE: The hex screw (10) is fixed with synthetic bonding agent!

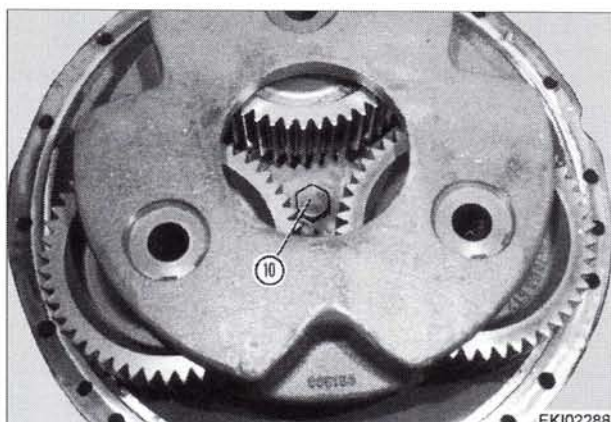
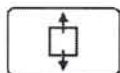

Fig. 6.

EKI02288
 1003609



If necessary:

Unclip circlip (4).

Press out the axle (3)

Remove the spur gear (2)

Fit the spur gears (2)

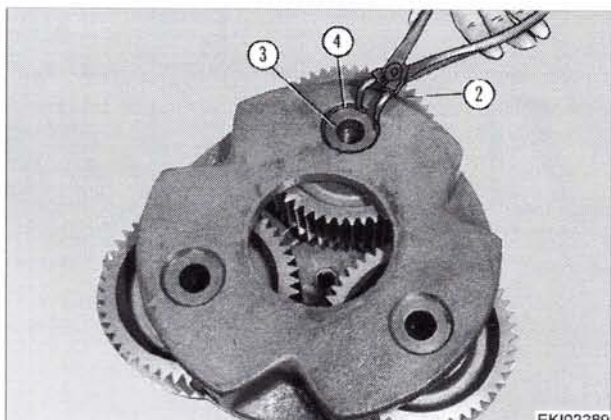
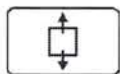

Fig. 7.

EKI02289
 1003610



Pre-tension the rear axle shaft bearing

Place one or two shims, order no. X534.739.501 (thickness: 1mm each) onto the rear axle shaft (31).

Then re-fit the planetary carrier.

NOTE: If no shims are available, the rear axle shaft bearing can also be pre-tensioned using a (self made) clamping bush.

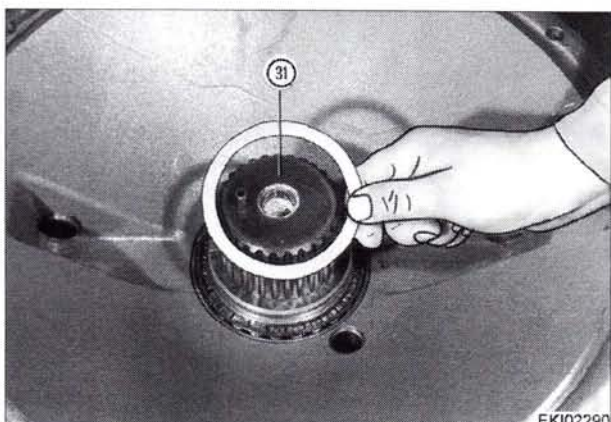

Fig. 8.

EKI02290
 1003611

919 .. 0101-1000
 919 .. 1001-
 922 .. 0101-1000
 922 .. 1001-
 925 .. 0101-1000

925 .. 1001-
 928 .. 0101-1000
 928 .. 1001-
 931 .. 0101-1000
 931 .. 1001-

934 .. 0101-1000
 934 .. 1001-

T001212
 Version 1
 07-11-2007

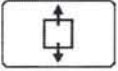

Pre-tension the rear axle shaft bearing with the hex screw (10).

Remove the planetary carrier (14) once more.

NOTE: Do not turn the rear axle shaft (31)!

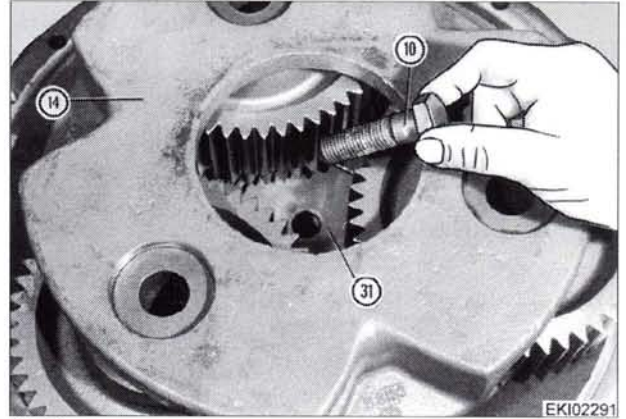
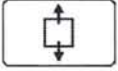

Fig. 9.

EKI02291
1003612



Press the sectioned ring (25) out of the rear axle shaft (31) groove

Remove shims

Withdraw the dowel pin (12)

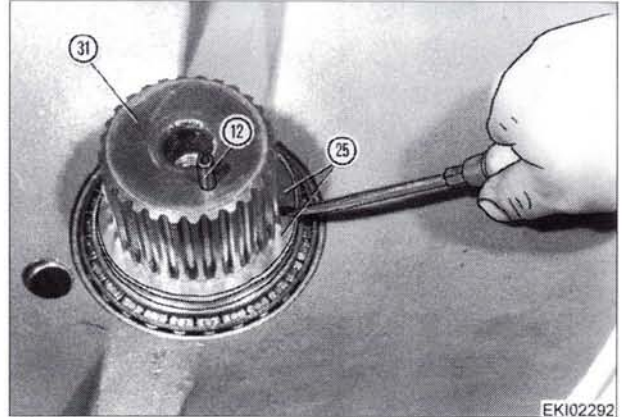
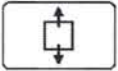

Fig. 10.

EKI02292
1003613



Attach the protective cap X 899.980.157.000 to the rear axle shaft



Fig. 11.

EKI02293
1003614

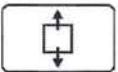

Attach assembly clamps (self made, see picture) to the rear axle shaft (31).

Force the rear axle shaft out (31) by knocking on a metal block.

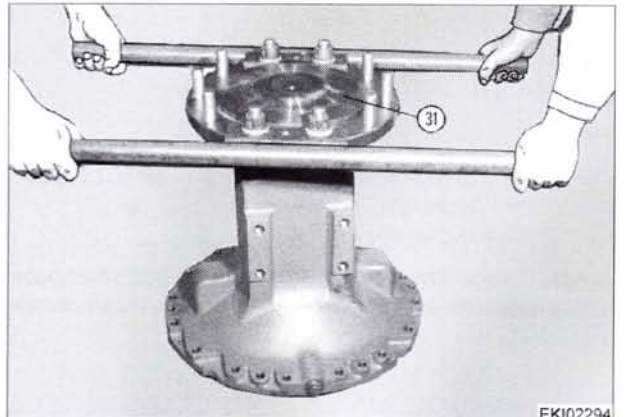
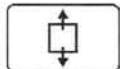

Fig. 12.

EKI02294
1003615



Withdraw the inner ring from the taper roller bearing (28) using X899.980.159.000 extraction tool. Then push the shaft seal ring (30) off.

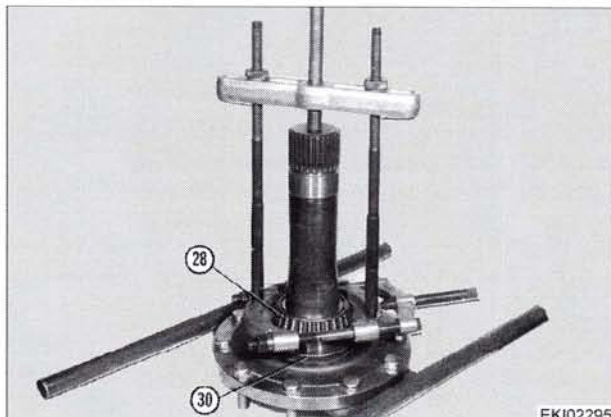
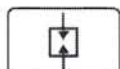

Fig. 13.

EKI02295
1003616

Assembling axle drive



Assembly:

Where removed:

Press the outer ring of the taper roller bearing (28) in as far as it will go.

Emplace the snap ring (29) into the groove.

On the opposite side, press the outer ring of the taper roller bearing in as far as it will go.



Fig. 14.

EKI02296
1003617

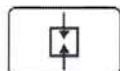

Heat the inner ring of the taper roller bearing (28) to approx. 80°C and place it in the axle housing (15).

Coat the outside of the shaft seal ring (30) with sealing compound X903.051.711, and the inside with a (1:1) spirit/water mixture and press it in as far as it will go.

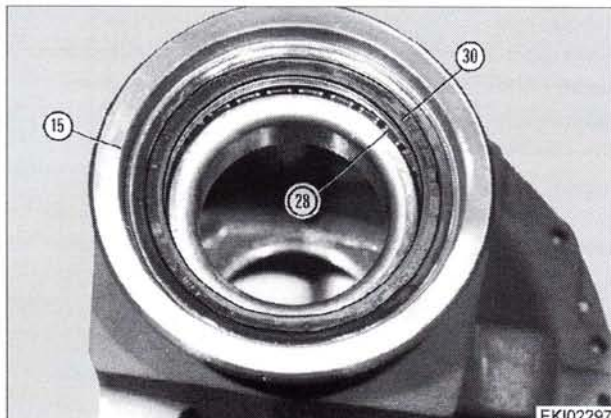
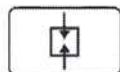

Fig. 15.

EKI02297
1003618



Before the inner ring cools down, insert the rear axle shaft (31) with the assembly clamps (self made, see picture) attached as far as it will go.

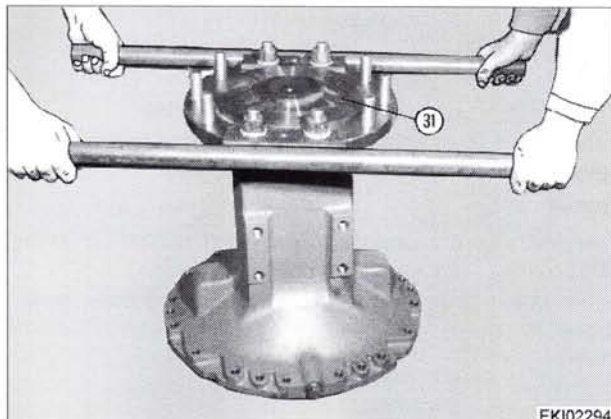

Fig. 16.

EKI02294
1003615

919 .. 0101-1000
919 .. 1001-
922 .. 0101-1000
922 .. 1001-
925 .. 0101-1000

925 .. 1001-
928 .. 0101-1000
928 .. 1001-
931 .. 0101-1000
931 .. 1001-

934 .. 0101-1000
934 .. 1001-

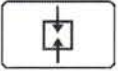

Turn the axle housing (15) round.
Heat the inner ring of the taper roller bearing (27) to approx. 80°C and press it on as far as it will go.
Lubricate the rear axle shaft bearing with transmission oil.

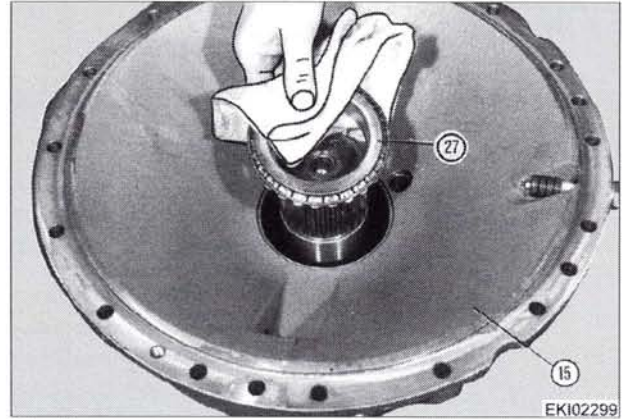
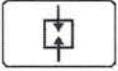

Fig. 17.

EKI02299
1003620

Support the axle housing (15) from below.
There must be slight play in the rear axle shaft bearing.
Attach the torque gauge X899.980.150.000 and measure and note the torque resistance of the shaft seal ring, e.g. 5.0 Nm.

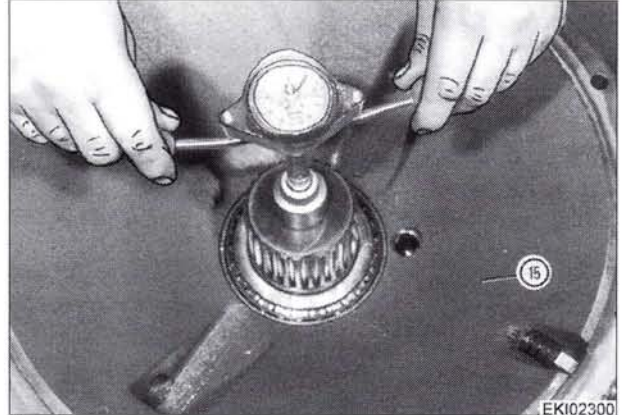
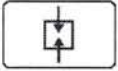

Fig. 18.

EKI02300
1003621

Select the thickness of the shims (26) so that the sectioned ring has no play once in place.

NOTE: If possible, emplace the shims (26) so that the 1.0 mm thick shim (26) faces the sectioned ring (25).

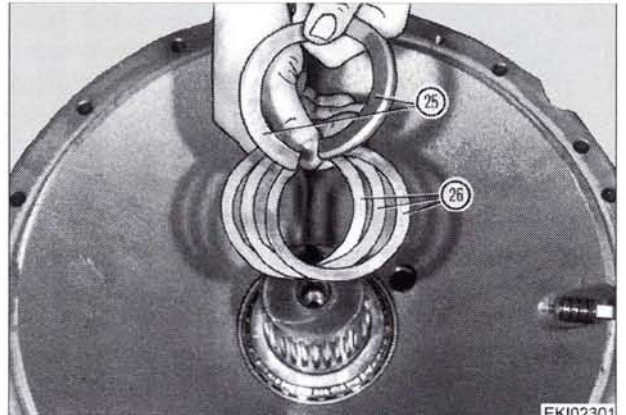
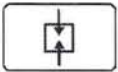

Fig. 19.

EKI02301
1003622

Place two shims, order no. X534.739.501, (thickness: 1.0 mm each) onto the rear axle shaft (31).
Then attach and tighten the planetary carrier.
The torque resistance of the rear axle shaft bearing must increase.

NOTE: If the torque resistance does not increase, remove the planetary carrier once again and insert further shims (26) beneath the sectioned ring (25).

Then pre-tension the rear axle shaft bearing once more.

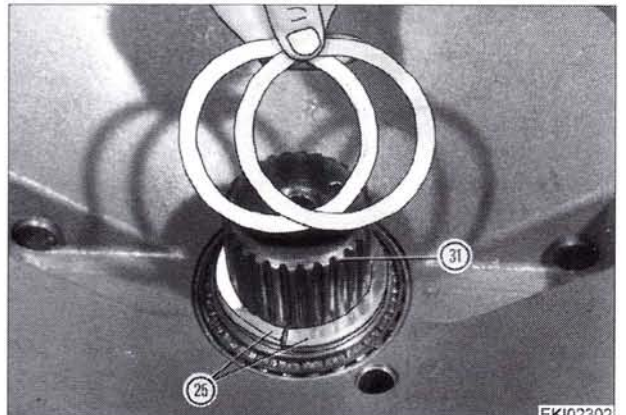
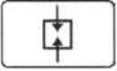

Fig. 20.

EKI02302
1003623



Lightly tap the bearing in both directions, thus releasing its tension.
Remove the planetary carrier once more.
Select a shim (26) thickness that enables the sectioned ring (25) to be pushed in by light tapping with a hammer.
Insert the dowel pin (12) into the rear axle shaft (31).

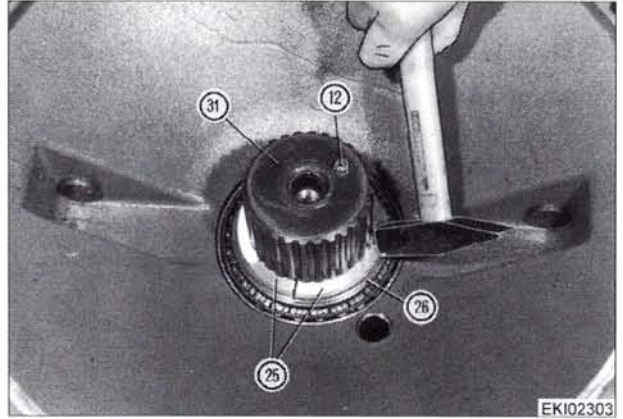
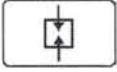

Fig. 21.

EKI02303
1003624



Coat the threads of the hex screw (10) with synthetic bonding agent X903.050.084 and tighten to a torque of **350 Nm** .
Lightly tap the bearing in both directions, thus releasing its tension.

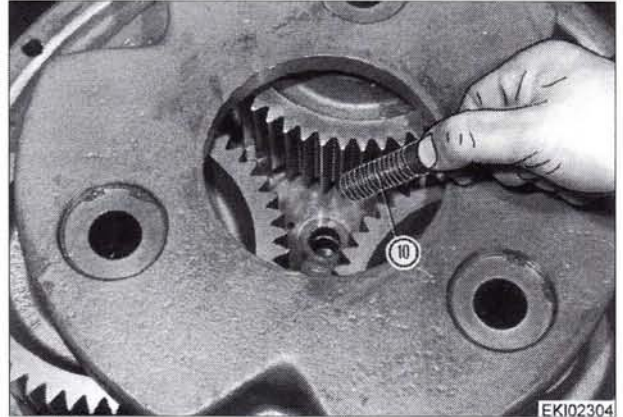
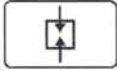

Fig. 22.

EKI02304
1003625



Measure and note the torque resistance of the shaft seal ring and bearing with torque gauge X899.980.150.

Target value: 4.0 to 6.0 Nm (bearing) + torque resistance (shaft seal ring e.g. 5.0 Nm) .

If there is any deviation correct the torque resistance with shims (26).

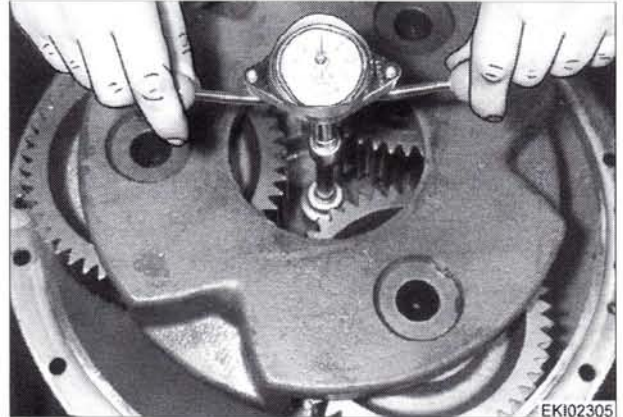
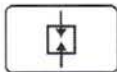

Fig. 23.

EKI02305
1003626



Check the axial play of the planetary carrier (14) with two mounting levers.

Target value: 0.2 to 0.5 mm axial play.

NOTE: Important – some axial play must be present.

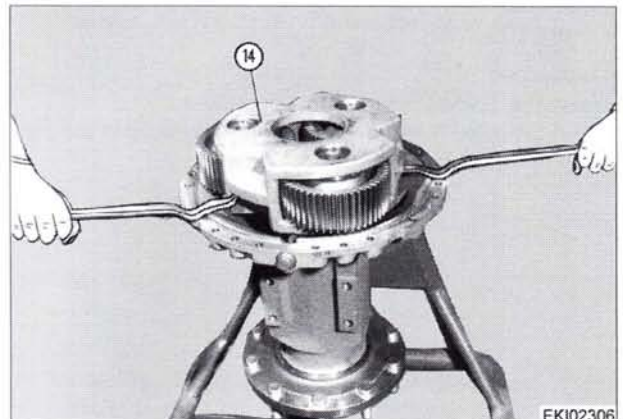
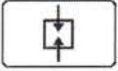

Fig. 24.

EKI02306
1003627

919 .. 0101-1000	925 .. 1001-	934 .. 0101-1000
919 .. 1001-	928 .. 0101-1000	934 .. 1001-
922 .. 0101-1000	928 .. 1001-	
922 .. 1001-	931 .. 0101-1000	
925 .. 0101-1000	931 .. 1001-	



If dismantled, attach the planet wheels.

Emplace the snap ring onto the groove of the bush and press the bush (arrow) into the spur gear (2) (planet wheel) until the snap ring engages.

NOTE: The bush (arrow) cannot be dismantled.

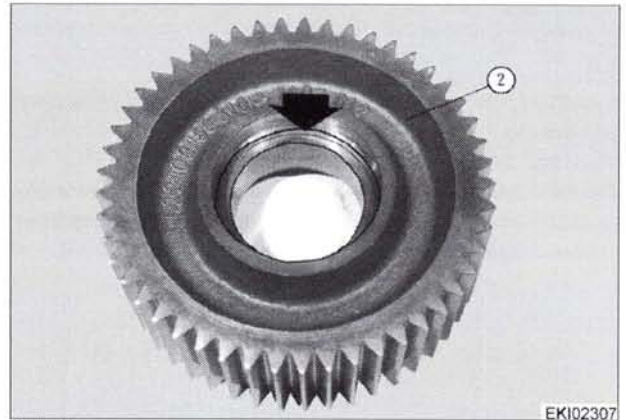
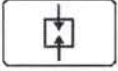

Fig. 25.

EKI02307
1003628



Using grease, stick the 19 rollers from the drum (5) into the spur gear (2). Then stick the drum (5) ring with grease into the spur gear (2). Pre-assemble the other side of the spur gear (2) logically.

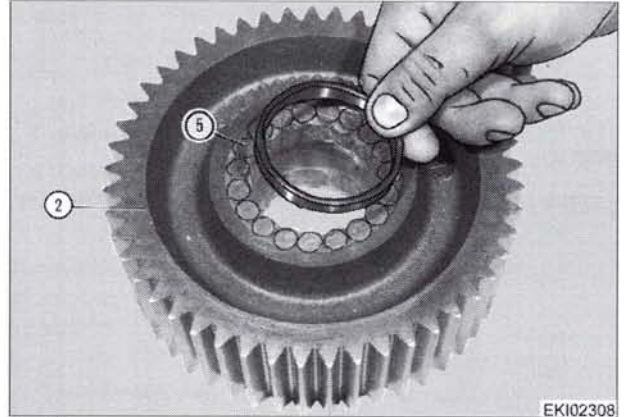
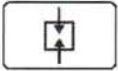

Fig. 26.

EKI02308
1003629



Place the circlip (4) into the groove of the planetary carrier (14).

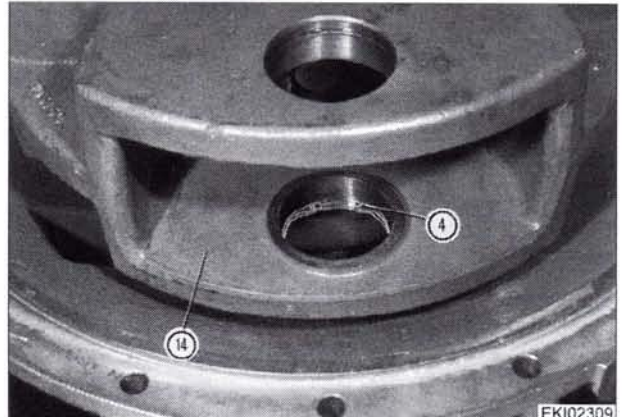
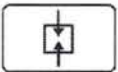

Fig. 27.

EKI02309
1003630



Insert the pre-assembled spur gear (2). Insert the axle (3) and circlip (4) into the groove in the planetary carrier (14).

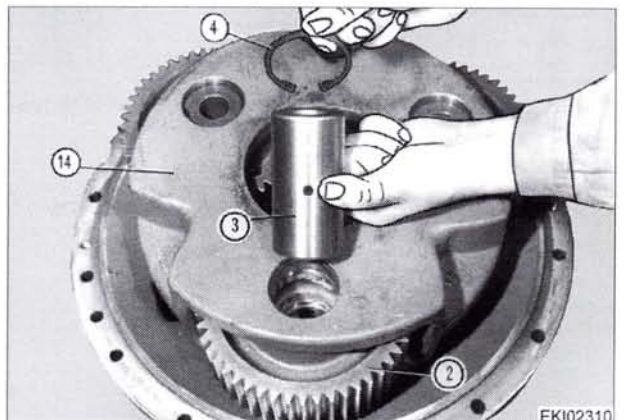
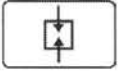

Fig. 28.

EKI02310
1003631



Clean the flange surface and then coat it with flange sealant X903.050.074.

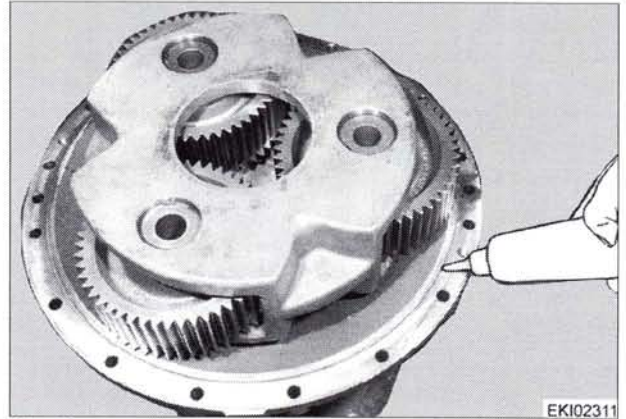
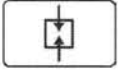

Fig. 29.

EKI02311
 1003632



Attach the ring gear (1).
 Tighten the socket head cap screws (19) to a torque of 86 Nm.

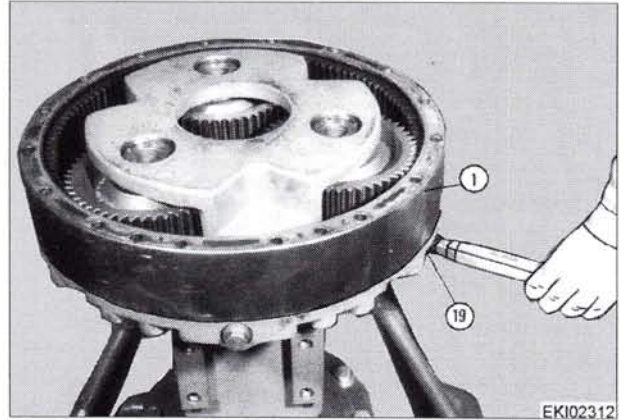

Fig. 30.

EKI02312
 1003633

