

FENDT

Werkstatthandbuch

Workshopmanual

Manuel d'atelier

Manual de taller

Manuale per l'officina

Werkplaatshandboek

FENDT 900 Vario COM III

X 990.005.057.012

1

FENDT

A	General
B	Faults
C	Documents and Diagrams
D	Component location
E	Testing
F	Setting and Calibration
G	Repair
H	Service – Info

1070

Transmission / Brake system

FENDT 900 Vario - COM III

Volume 1

0000	Overall system/tractor
1005	Overall system/transmission
1010	Transmission/differential
1015	Transmission/axle drive
1050	Transmission/housing
1070	Transmission / Brake system
1080	Transmission/drive train
1200	Transmission/front PTO
1220	Transmission / Live PTO
1320	Transmission/front wheel drive
2000	Overall system/engine
2010	Engine/cylinder head
2050	Engine/cooling
2060	Engine/fuel system
2210	Engine/crankcase
2312	Engine/lubrication
2400	Engine/exhaust system
2712	Engine/injectors
3000	Overall system/front axle
3120	Front axle/steering cylinder
3180	Front axle/cardan shaft

Volume 2

4000	Overall system/steering
4090	Steering system / hydraulic steering unit
5030	Vehicle layout/operator's seat
5500	Overall system/air conditioning system
8100	Overall system/cab
8610	Power lift/EPC electro-hydraulic control
8631	Power lift/hydraulic lift
8800	Overall system/compressed air system

Volume 3

9000	Overall system/electrical system
9015	Electrical system/starter lockout

FENDT 900 Vario - COM III

Volume 4

- 9410 Hydraulic pump installation/LS pump**
- 9430 Hydraulic pump installation/steering pump**
- 9534 Hydraulic piping/"Rüfa"reverse operation**
- 9600 Overall system/hydraulic equipment**
- 9605 Hydraulic equipment/hydraulic connections**
- 9610 Hydraulic equipment/central control block (ZSB)**
- 9620 Hydraulic equipment/valve fitting**
- 9700 Overall system/electronics**
- 9920 Service/special tools**
- 9975 Service/SERDIA - Deutz engine diagnostics program**

1070 Transmission / Brake system

C	Documents and diagrams	5
F	Setting and calibrating	15

C Documents and diagrams

1	Technical drawing of the rear wheel brake	7
2	Technical drawing of actuator cylinder and wheel brake cylinder	10
3	Technical drawing of the wheel brake cylinder	13

1 Technical drawing of the rear wheel brake

Rear wheel brake

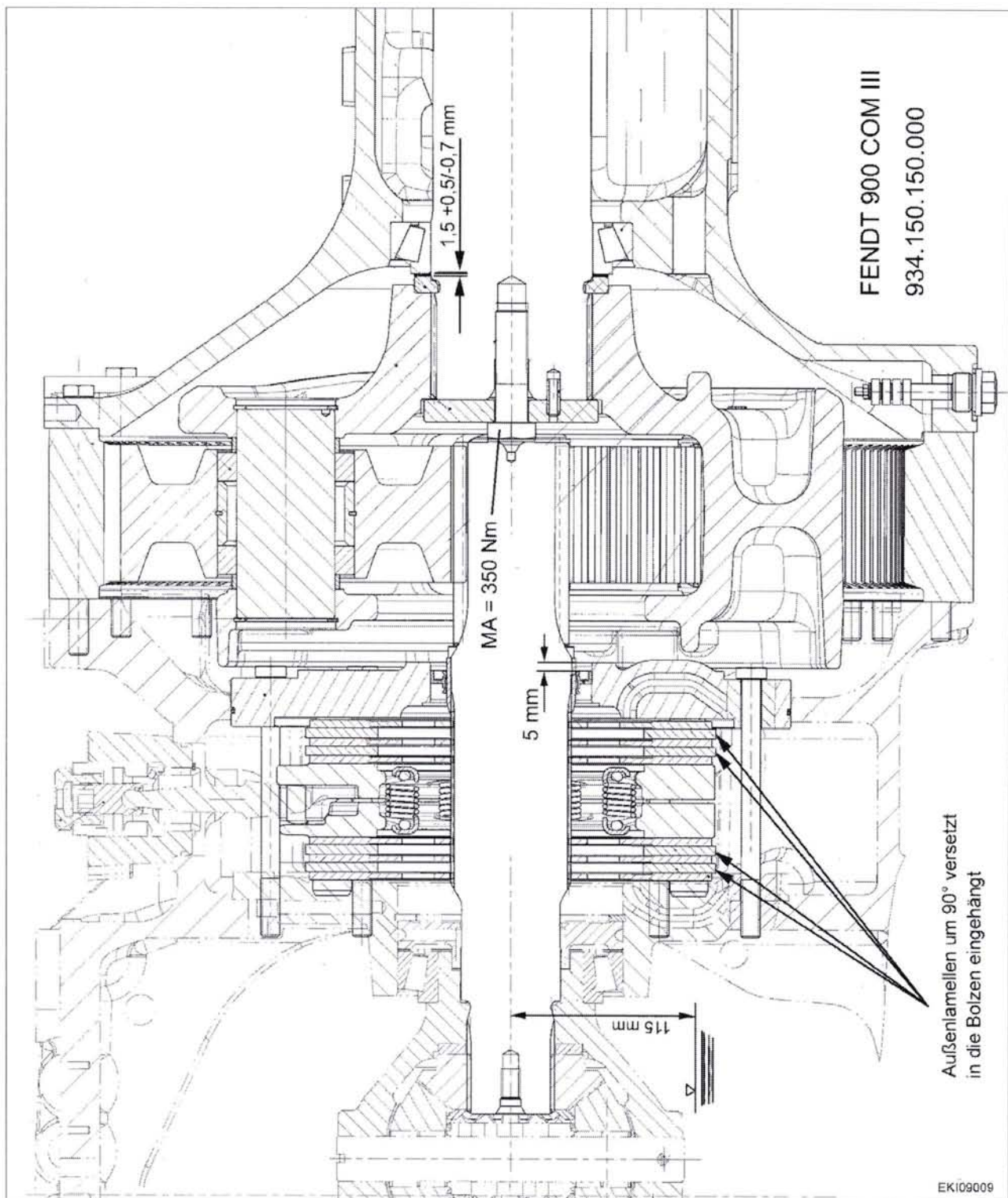

Fig. 1.

EKI09009

1003573

919 .. 0101-1000
 919 .. 1001-
 922 .. 0101-1000
 922 .. 1001-
 925 .. 0101-1000

925 .. 1001-
 928 .. 0101-1000
 928 .. 1001-
 931 .. 0101-1000
 931 .. 1001-

934 .. 0101-1000
 934 .. 1001-

T001210
 Version 1
 07-11-2007

Brake discs

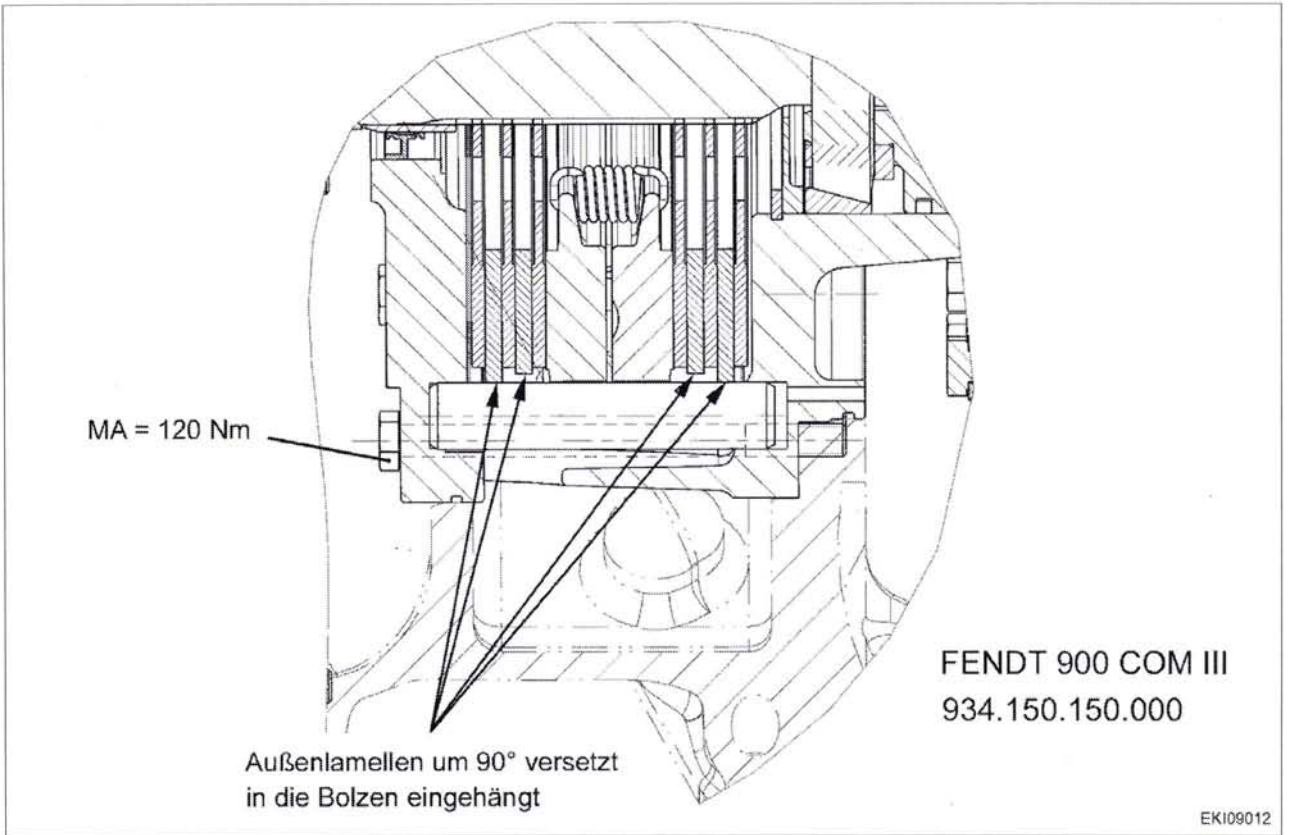

Fig. 2.

Actuator plate

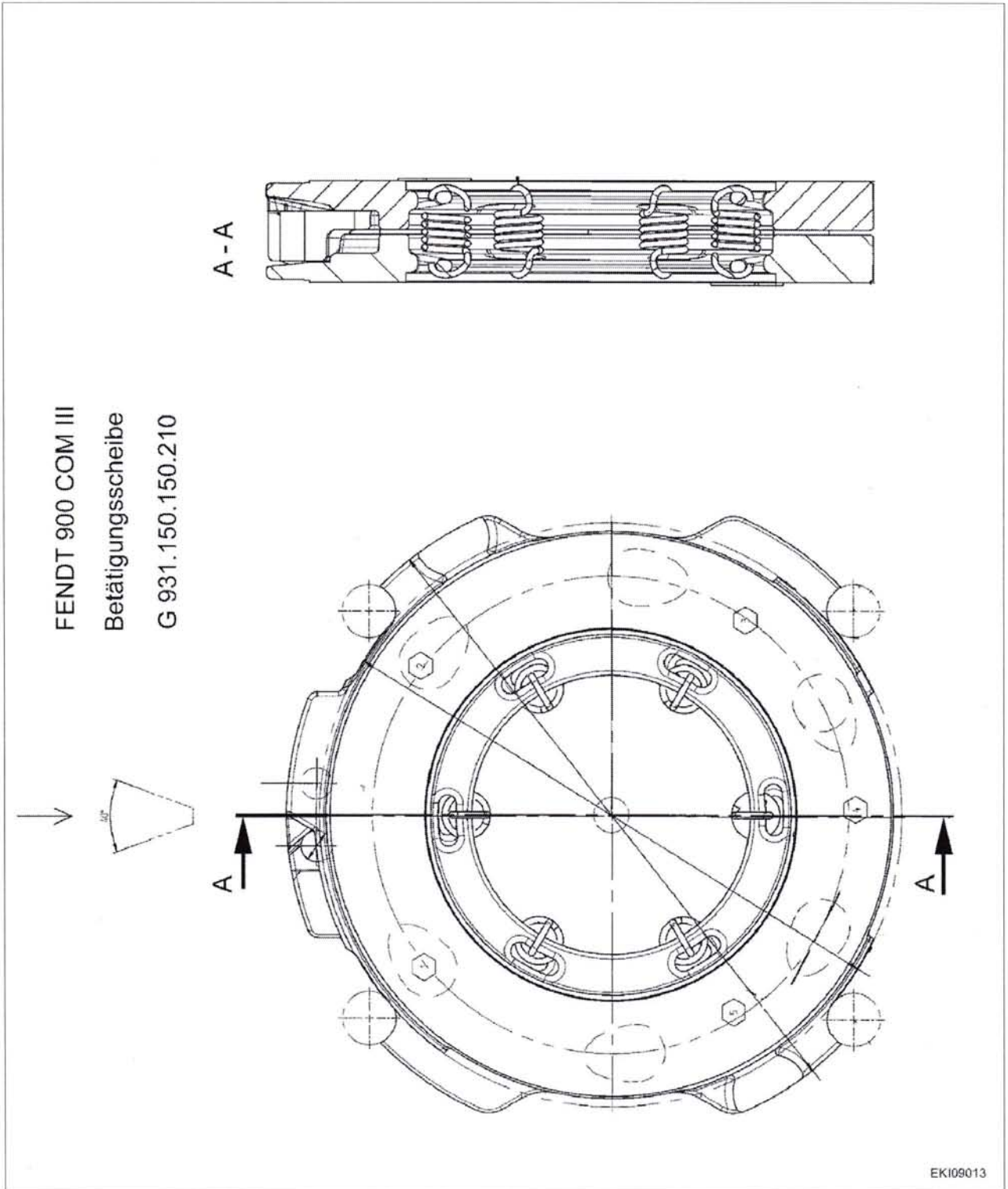

Fig. 3.

1003575

Rear wheel brake adjustment information

NOTE: Chapter 1070 Reg. F - Adjusting the rear wheel brake
 Chapter 1070 Reg. C - Technical drawing of the wheel brake cylinder

919 .. 0101-1000	925 .. 1001-	934 .. 0101-1000
919 .. 1001-	928 .. 0101-1000	934 .. 1001-
922 .. 0101-1000	928 .. 1001-	
922 .. 1001-	931 .. 0101-1000	
925 .. 0101-1000	931 .. 1001-	

T001210
 Version 1
 07-11-2007

2 Technical drawing of actuator cylinder and wheel brake cylinder

Diagram: Actuator cylinder and wheel brake cylinder

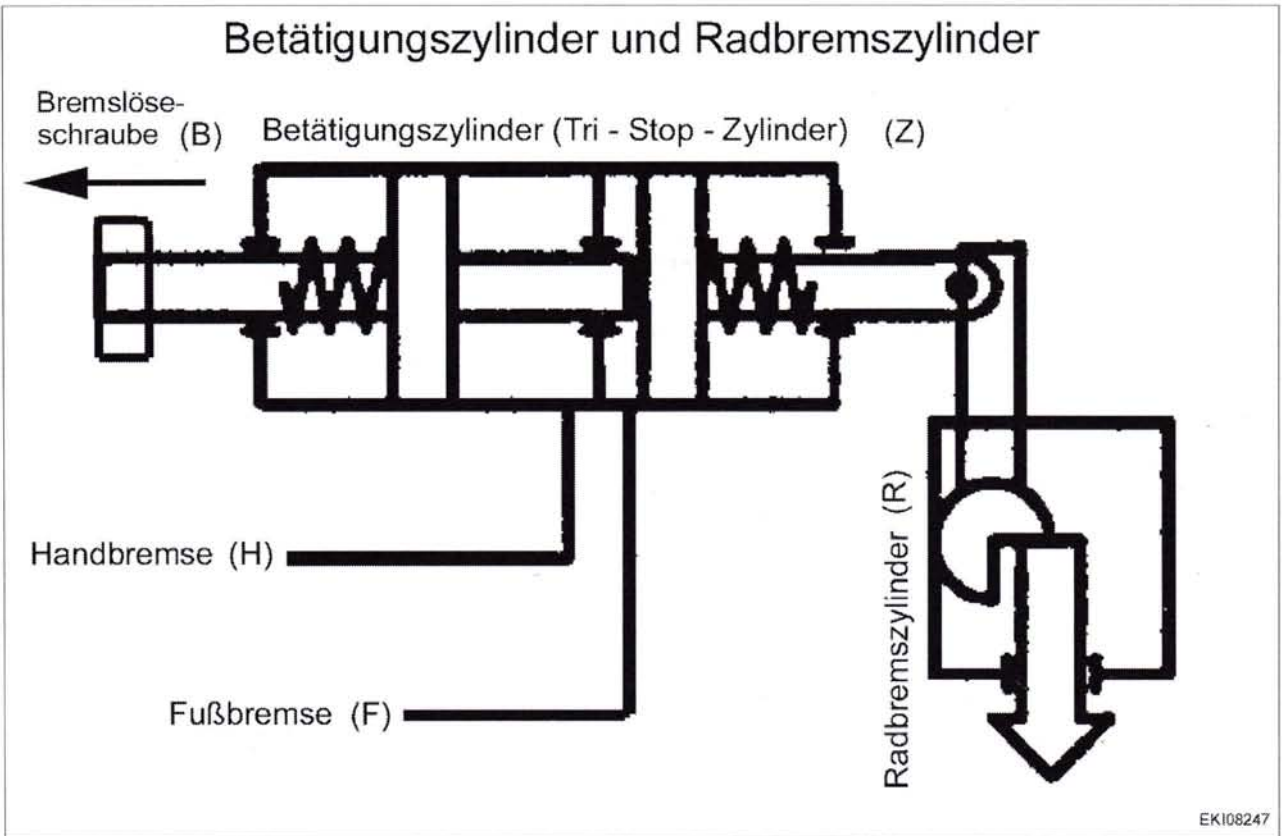
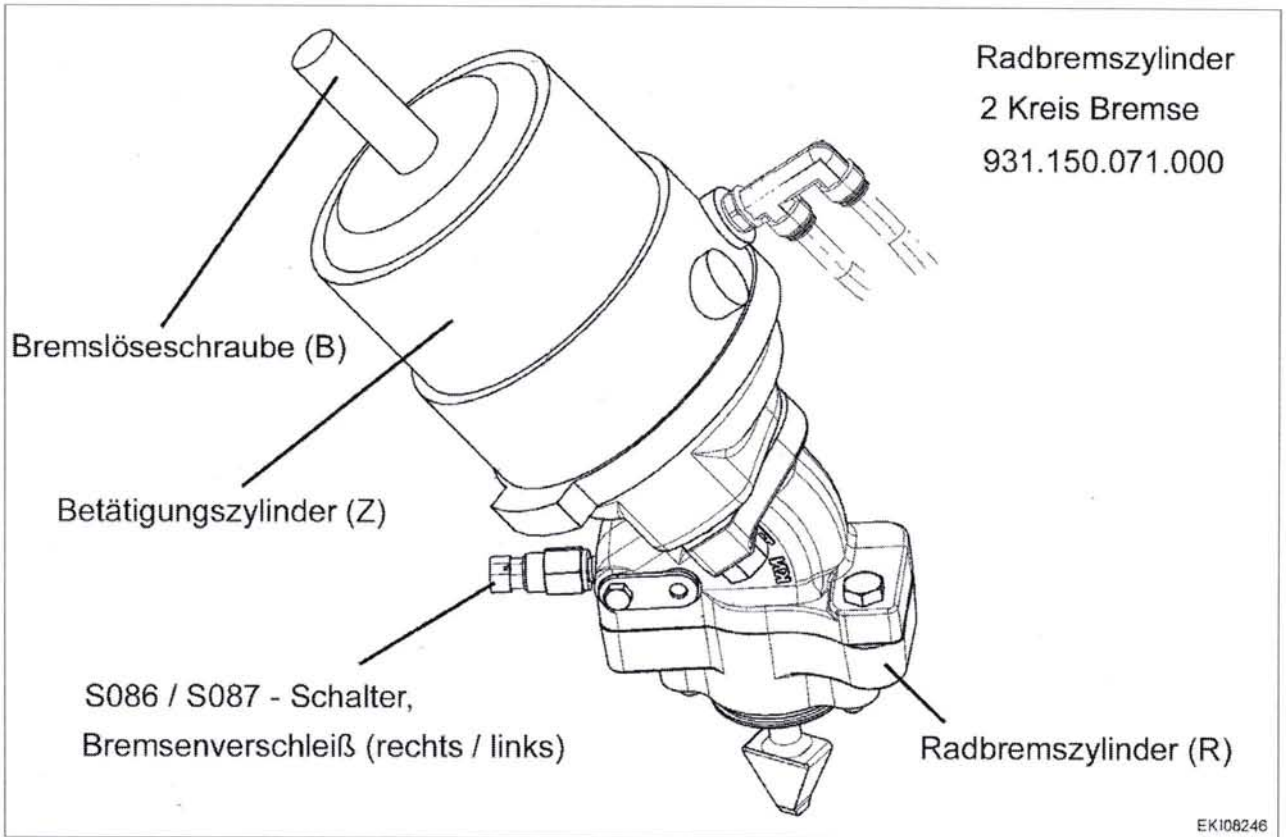

Fig. 4.

I001911

Item	Designation	Item	Designation
B	Brake release screw	R	Wheel brake cylinder
F	Foot brake connection (Note: The foot brake is applied with compressed air)	Z	Actuation cylinder (tri-stop-cylinder)
H	Hand brake connection (Note: The hand brake is released with compressed air)		

Wheel brake cylinder (2-circuit brake)



Radbremszylinder
 2 Kreis Bremse
 931.150.071.000

Fig. 5.

EKI08246

I001912

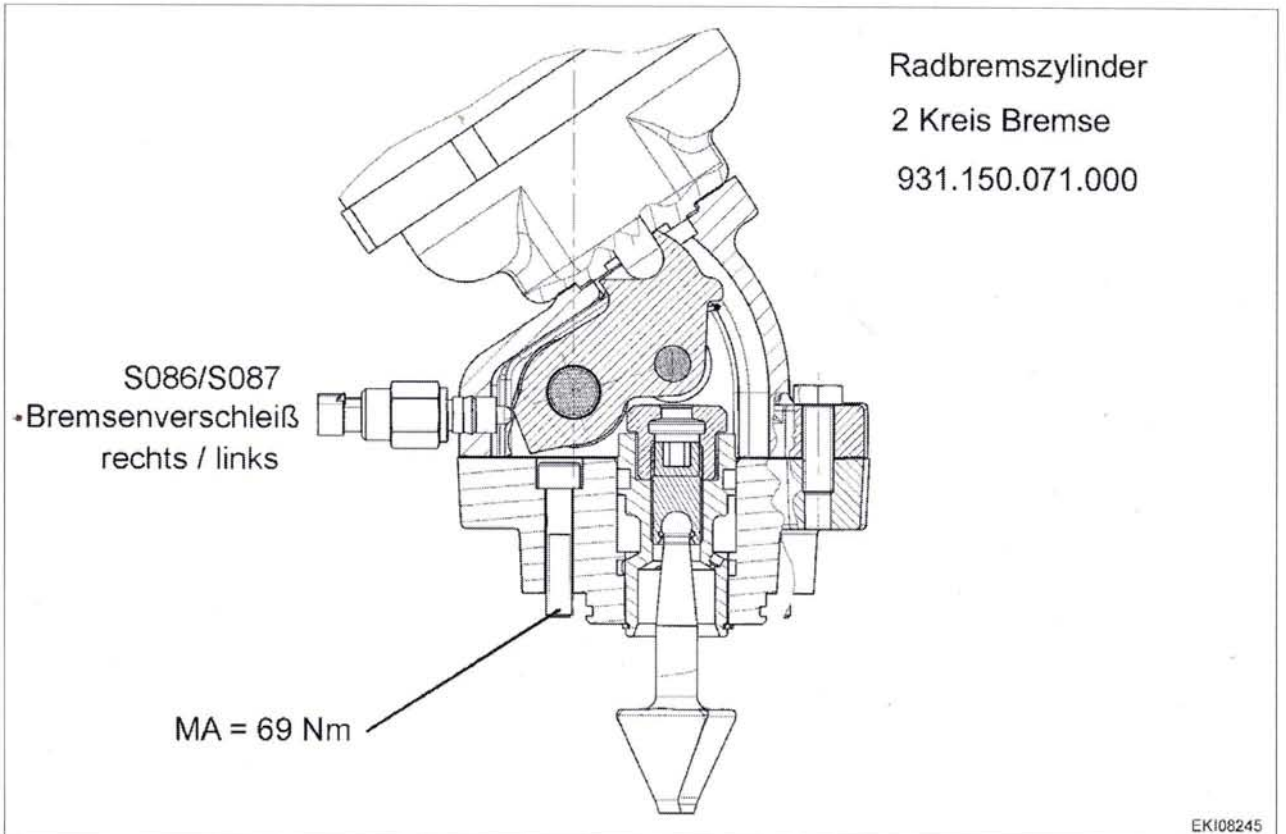

Radbremszylinder
 2 Kreis Bremse
 931.150.071.000

Fig. 6.

EKI08245

I001913

919 .. 0101-1000
 919 .. 1001-
 922 .. 0101-1000
 922 .. 1001-
 925 .. 0101-1000

925 .. 1001-
 928 .. 0101-1000
 928 .. 1001-
 931 .. 0101-1000
 931 .. 1001-

934 .. 0101-1000
 934 .. 1001-

T002613
 Version 1
 21-04-2009

Wheel brake cylinder (1-circuit brake)

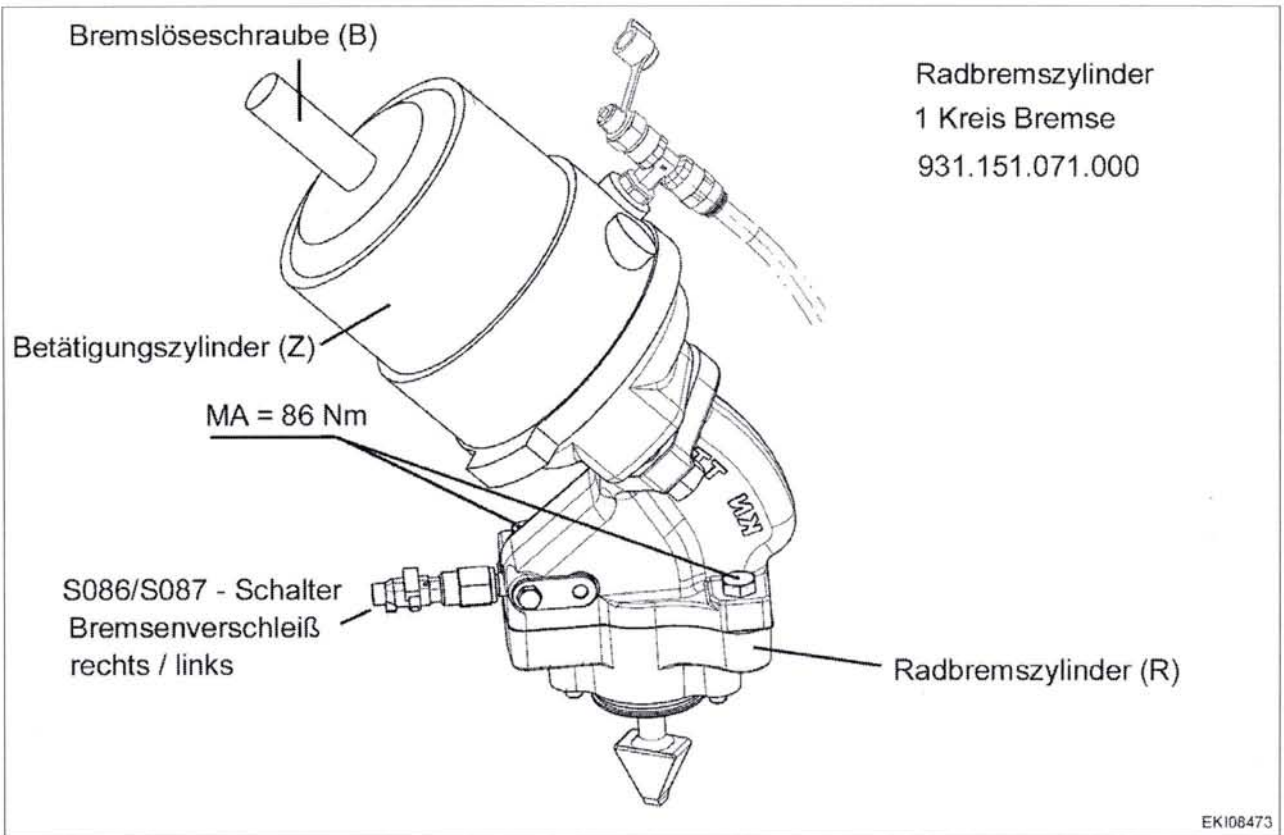

EKI08473

Fig. 7.

1001918

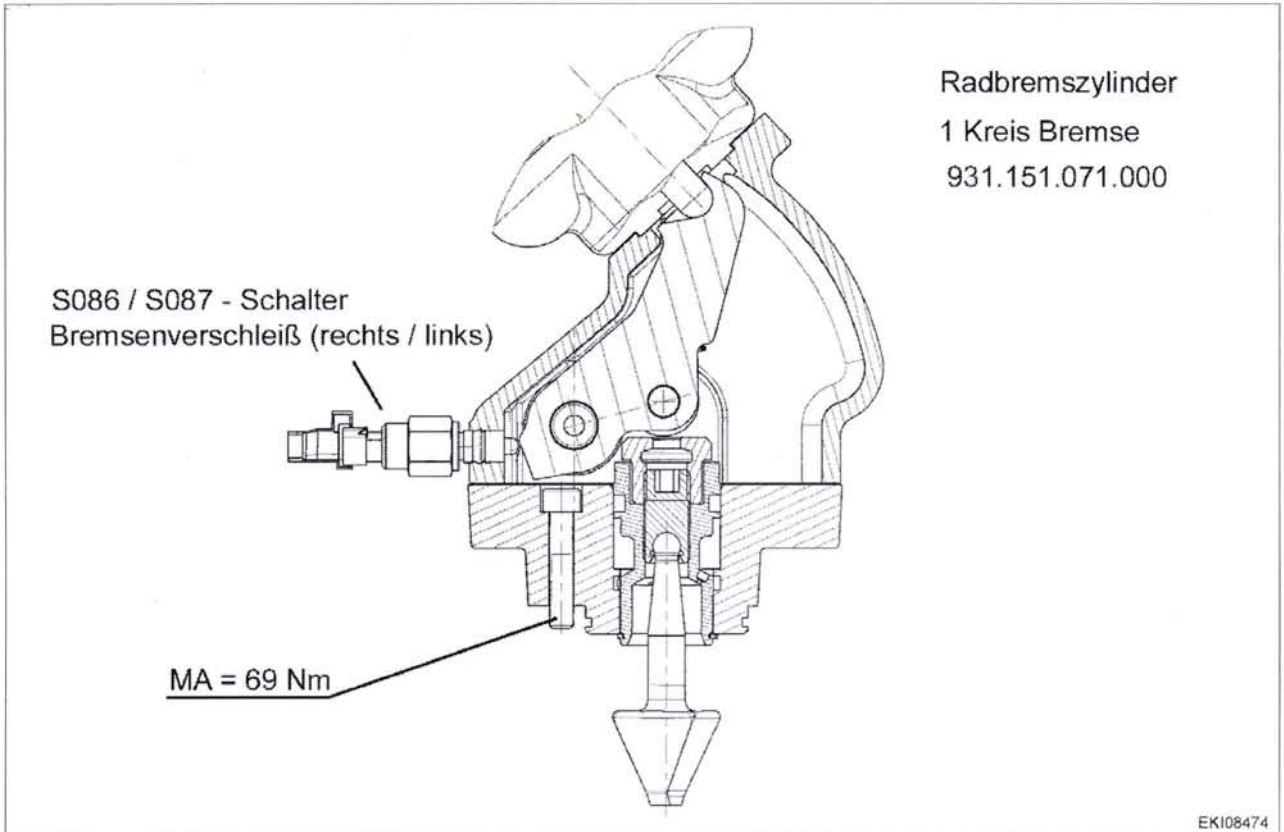

EKI08474

Fig. 8.

1001919

3 Technical drawing of the wheel brake cylinder

Wheel brake cylinder, 1-circuit brake (40, 50 km/h)

1-circuit = Rear wheel brake
 + 4WD engagement when braking

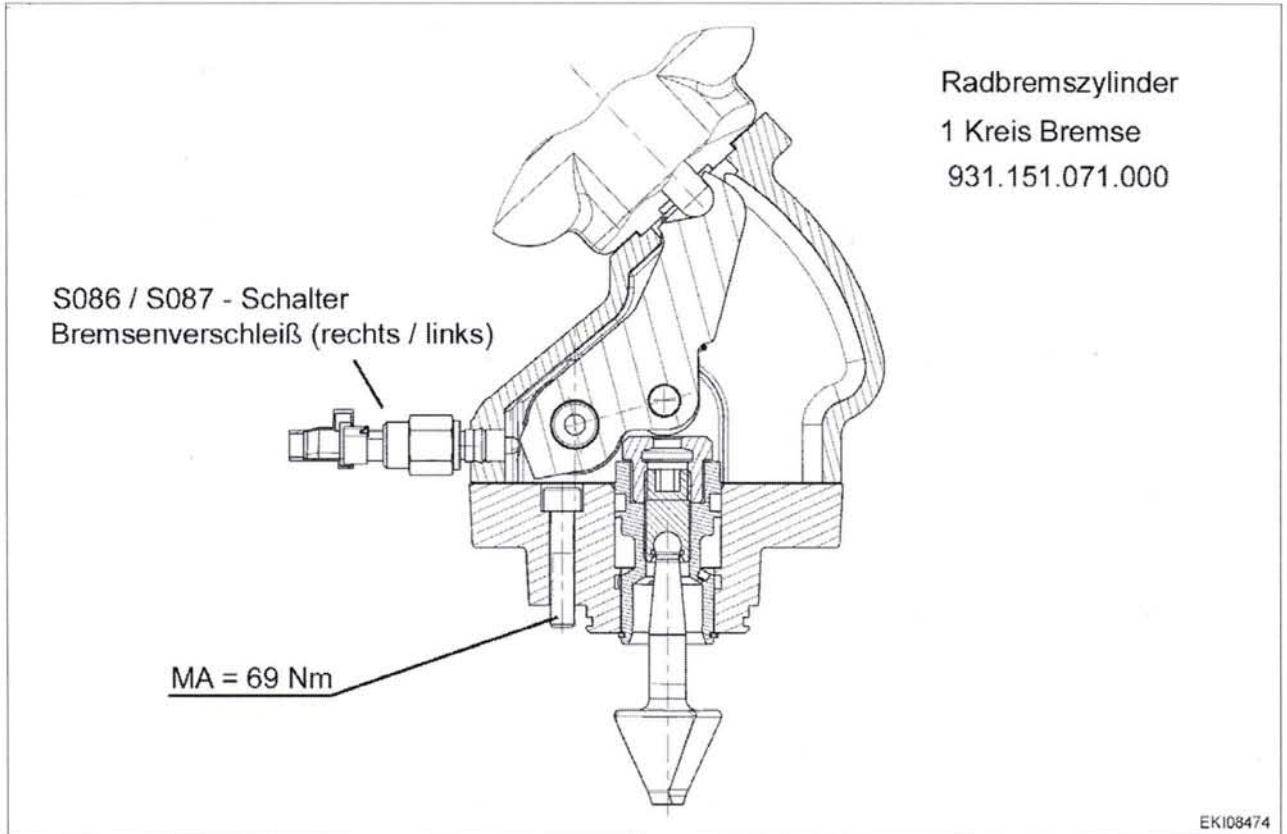

Fig. 9.

EKI08474

1001919

Wheel brake cylinder, 2-circuit brake (40, 50, 60 km/h)

1-circuit = Rear wheel brake
2-circuit = Front wheel brake

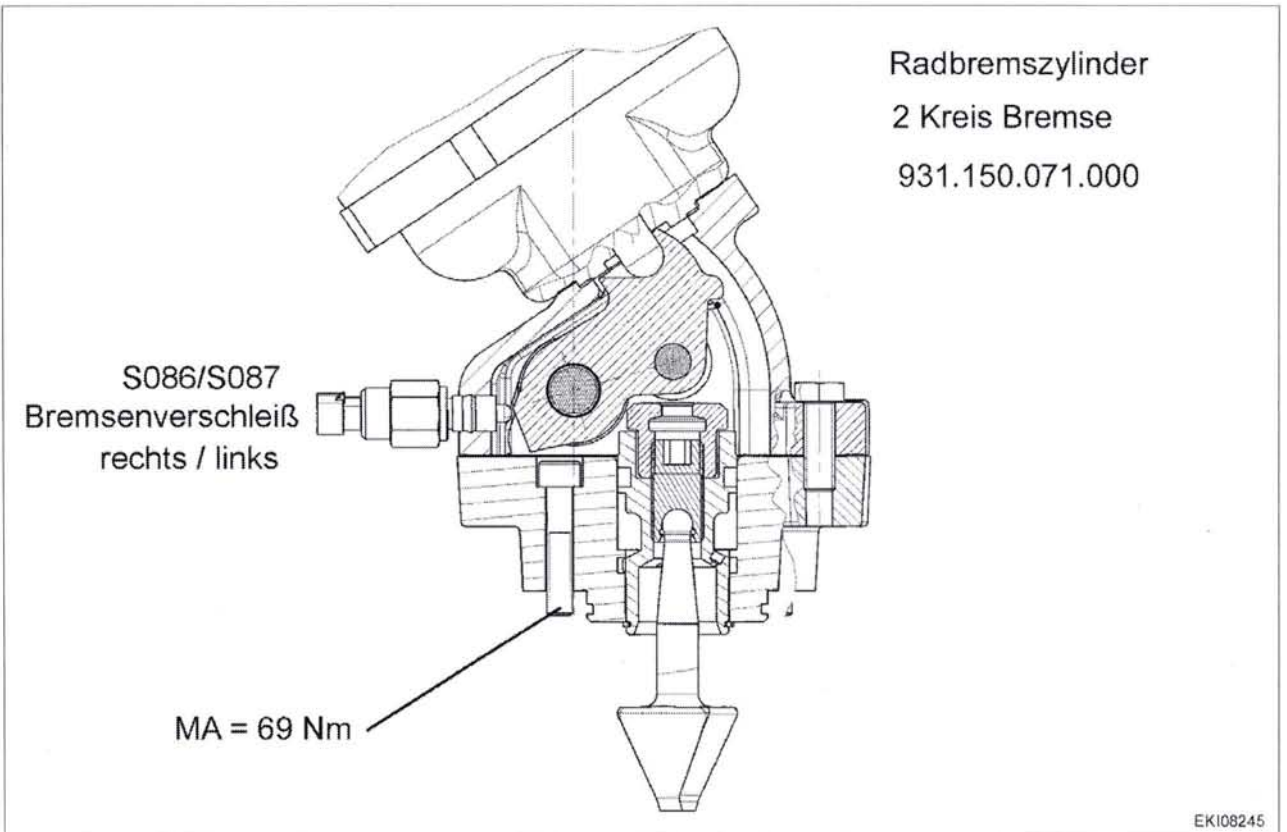

Fig. 10.

Testing options and adjustment of the tractor brake

NOTE: For brake actuation, please see:

Chapter 8800 Reg. C – 1-circuit brake diagram (compressed air system)

Chapter 8800 Reg. C – 2-circuit brake diagram (compressed air system)

NOTE: For checking tractor brake (compressed air system), please see:

Chapter 8800 Reg. E - Checking compressed air system (area: front wheel brake, rear wheel brake, hand brake)

NOTE: Adjusting the wheel brake cylinder: see §1

NOTE: Monitoring brake wear: see §113

NOTE: Adjustment of S086/S087: see §3

F Setting and calibrating

1	Adjusting rear wheel brake.	17
2	Magnet setting for S005/S006 switch, right/left brake	21
3	S086/S087 switch, adjust brake wear	23

1 Adjusting rear wheel brake

Preliminary work:

- Position the tractor on a level surface and ensure it cannot move
- Apply the hand brake
- Remove the rear wheel

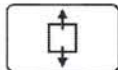

Unscrew the hand brake release screw on the Tristop cylinder by turning counterclockwise until it becomes noticeably more difficult to turn, then tighten as far as it will go with a spanner (SW24)



Fig. 1.

1002468

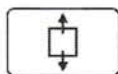

Unplug the air hoses and sensors



Fig. 2.

1002469

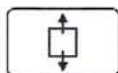

To release the air hoses, push the plastic ring back and withdraw the hose

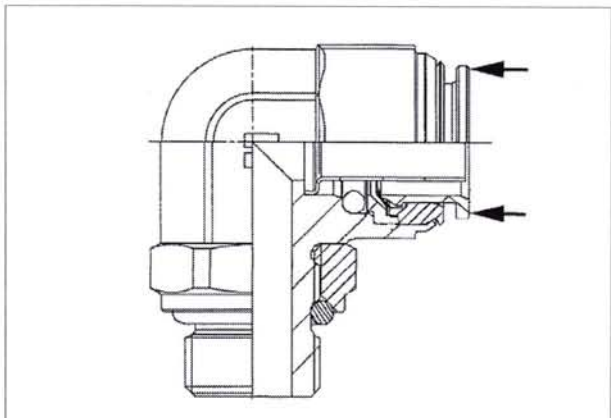
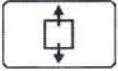

Fig. 3.

1001760



Loosen the fixing bolts on the upper part of the cylinder

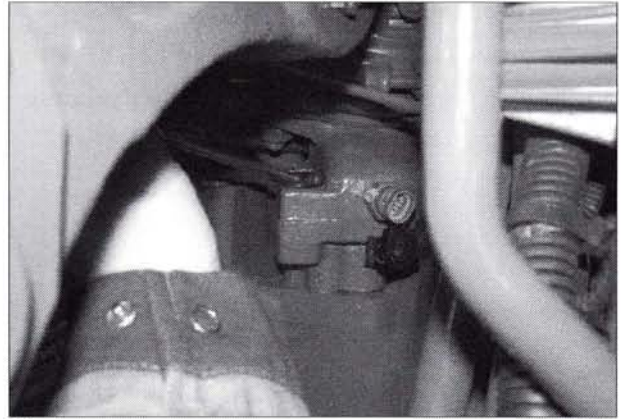
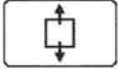

Fig. 4.

1002470



Remove the Tristop cylinder and the cylinder upper part

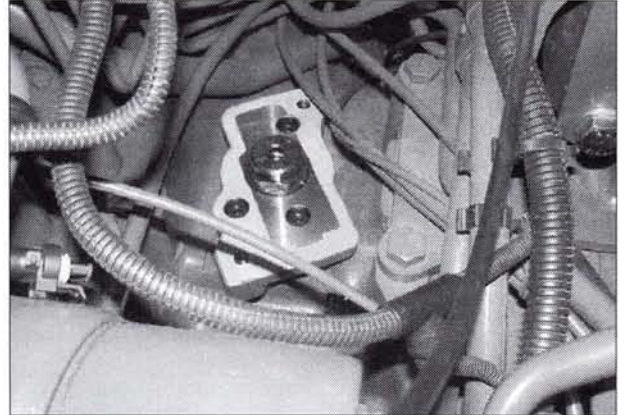
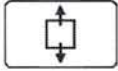

Fig. 5.

1002477



Loosen the locknut (SW 36) on the lower part of the cylinder, holding the guide piston (SW41) against it.

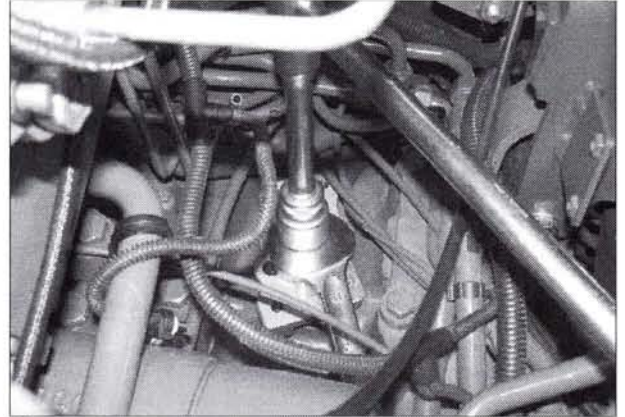

Fig. 6.

1002471

Screw in the adjustment screw and tighten it to a torque of 30 Nm (setting the brake)



Fig. 7.

1002473

Loosen the adjustment screw (approx. 1 turn)



Fig. 8.

I002472

Tighten the adjustment screw to a torque of 7 Nm (or block rear wheel)



Fig. 9.

I002474

Unscrew the adjustment screw 6.5 turns

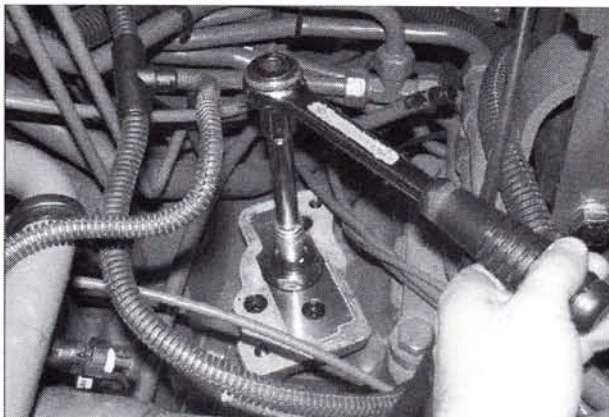

Fig. 10.

I002472

Fix the adjustment screw and tighten the locknut



Fig. 11.

I002475

919 .. 0101-1000
 919 .. 1001-
 922 .. 0101-1000
 922 .. 1001-
 925 .. 0101-1000

925 .. 1001-
 928 .. 0101-1000
 928 .. 1001-
 931 .. 0101-1000
 931 .. 1001-

934 .. 0101-1000
 934 .. 1001-

Tighten the locknut and guide piston to a torque of 80 Nm + 20 Nm

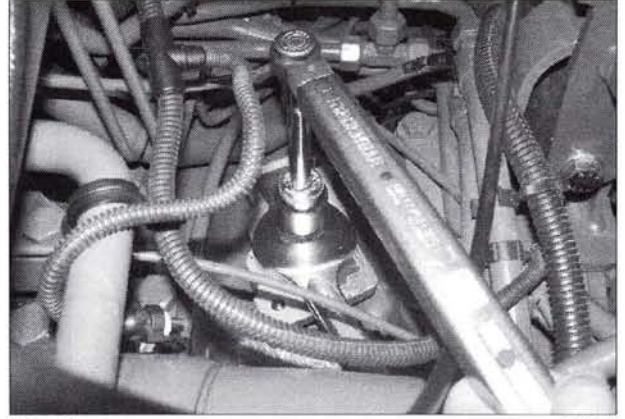
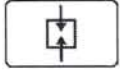

Fig. 12.

1002476



Fit the cylinder upper part and Tristop cylinder and tighten the fixing bolts
Tightening torque: 86 Nm



Fig. 13.

1002470

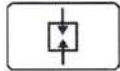

Attach the hoses and cables



Fig. 14.

1002469

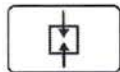

Screw in the hand brake release screw on the Tristop cylinder in a clockwise direction



Fig. 15.

1002468

2 Magnet setting for S005/S006 switch, right/left brake

Setting the S005/S006 switch magnets

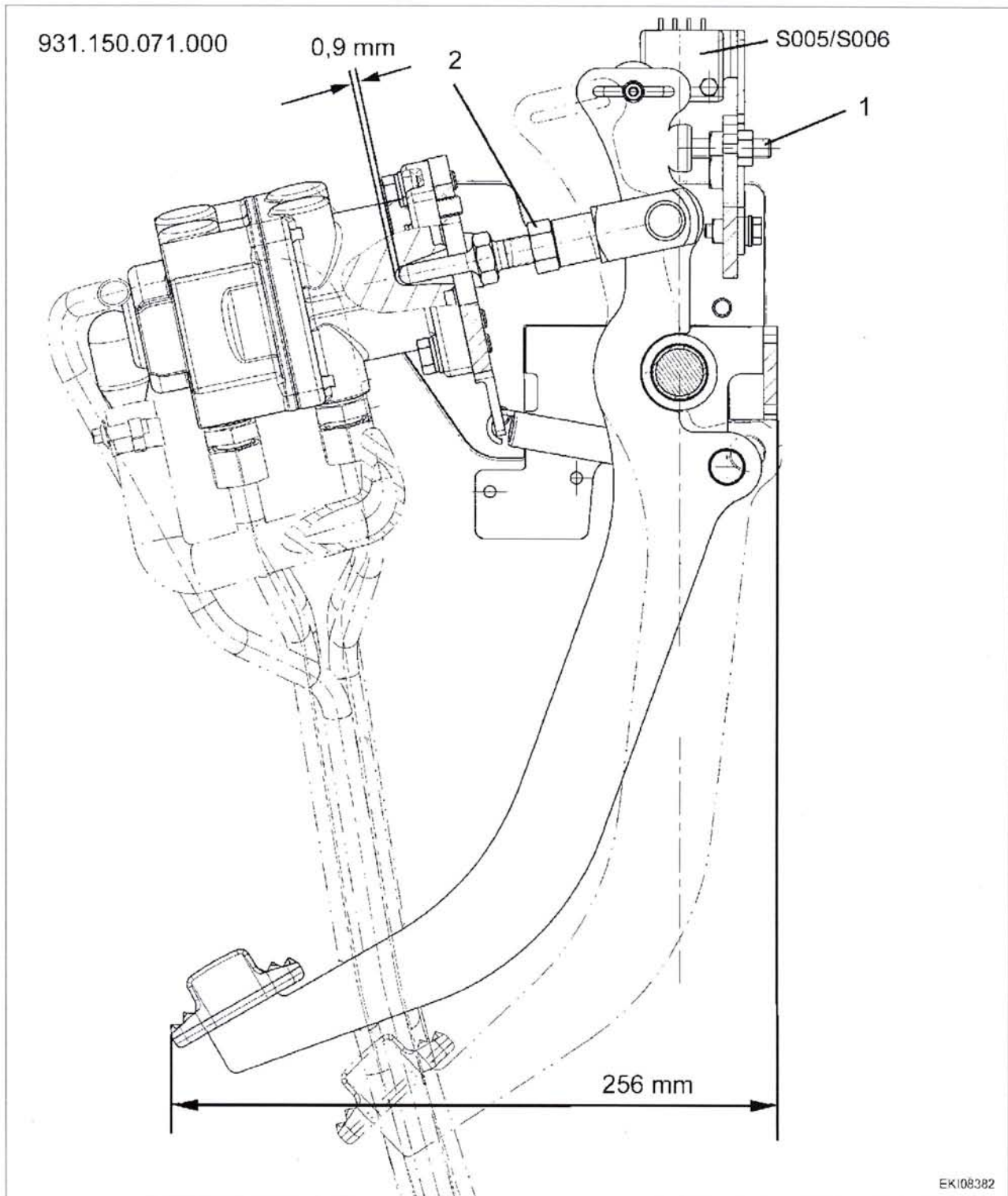

Fig. 16.

I001649

Setting instructions for brake pedal

Set the adjustment screw (1) to **256 mm**.

Adjust piston rod play 0.9 mm (1/2 turn on the push rod (2) equals approx. 5 mm pedal travel).

919 .. 0101-1000
 919 .. 1001-
 922 .. 0101-1000
 922 .. 1001-
 925 .. 0101-1000

925 .. 1001-
 928 .. 0101-1000
 928 .. 1001-
 931 .. 0101-1000
 931 .. 1001-

934 .. 0101-1000
 934 .. 1001-

T002834
 Version 1
 04-09-2009

Setting instructions for magnet (4)

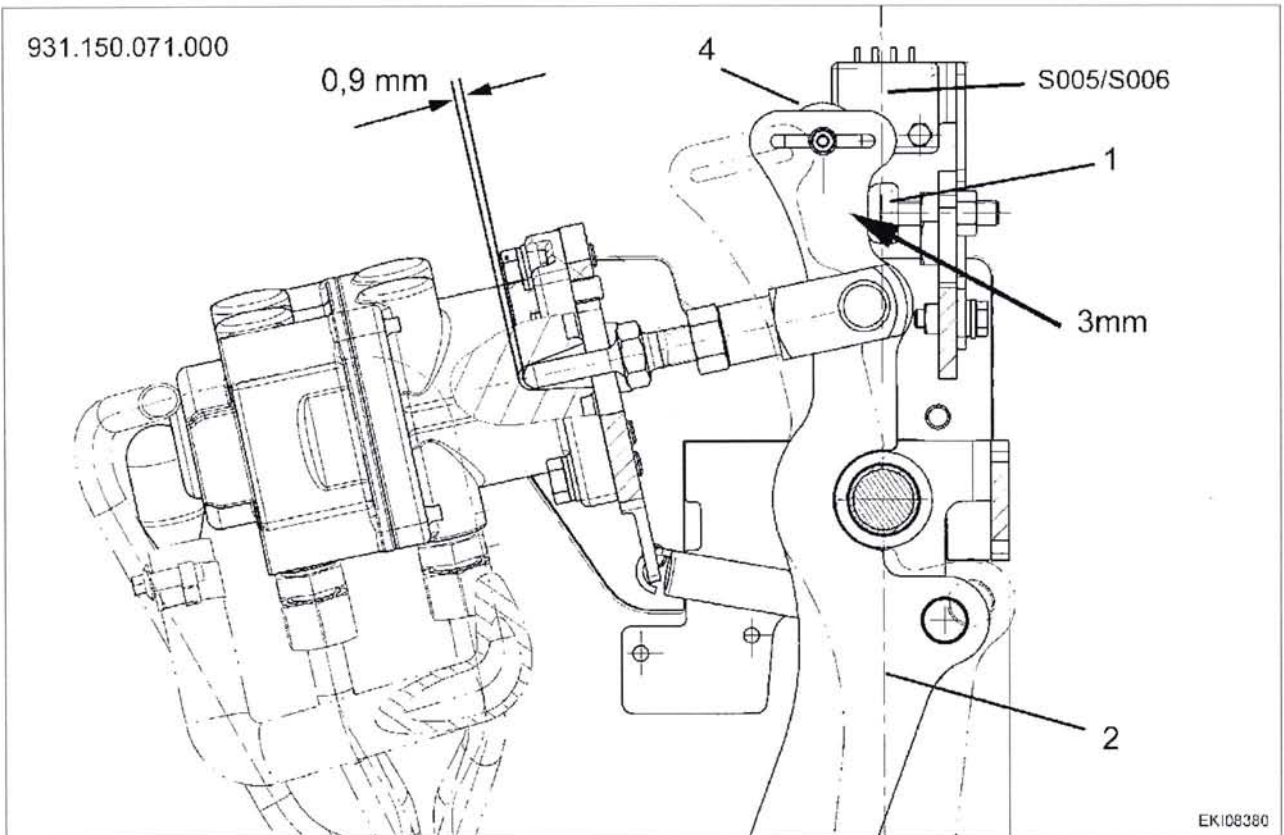

Fig. 17.

I001650

If necessary: unlock brake pedals, **set individually.**

Place shims between buffer (1) and brake pedal (2) to provide a space of 3 mm.
This corresponds to a pedal travel of approx. 11 mm.

Connect X899.980.246.206 adapter cable only to **S005** - Switch, right brake.

Connect multimeter (ohmmeter) to pin 3 and pin 4.

Push magnet (4) towards **S005** - Switch, right brake until the ohmmeter displays a resistance of approx. 121 ohms (switch closed)

Screw magnet (4) tight.

Remove shims (3 mm) from between the buffer (1) and the brake pedal (2).

NOTE: The setting for **S006** - Switch, left brake is carried out in the same way

Checking setting of magnet for S005/S006 switch

Measure pin 3 and 4 with multimeter (ohmmeter).

Unlock brake pedals.

Brake pedal in rest position (solenoid switch closed).
(resistance approx. 121 ohms)

Slowly operate single wheel brake (the solenoid switch must open).

After the brake pedal has travelled approx. 28 mm, the S005 - Switch, right brake opens (resistance approx. 510 ohms).

When the brake pedal returns to its rest position, the **S005** - Switch, right brake must close no later than 5 mm before the pedal reaches its rest position (resistance approx. 121 ohms)

NOTE: The check for the **S006** - Switch, left brake is carried out in the same way

3 S086/S087 switch, adjust brake wear

NOTE:

- Release handbrake, ensuring that there is sufficient pressure in the tank
- Foot brake **not** applied

 **DANGER: Secure the vehicle to prevent it from rolling away!**

Disconnect plug from the switch and connect adapter cable X899.980.246.204

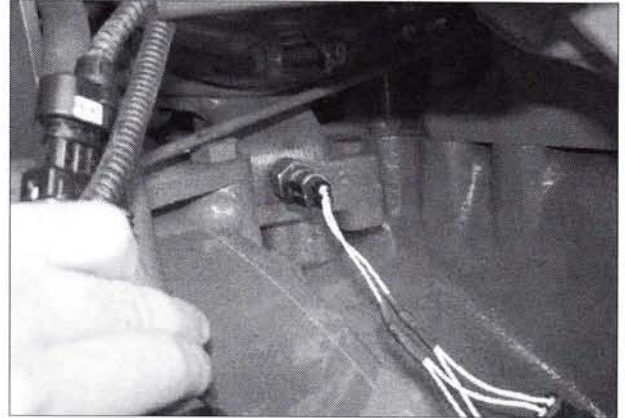

Fig. 18.

1007221

Connect multimeter to the adapter cable



Fig. 19.

1007220

Turn switch until multimeter switches to 510 Ohm

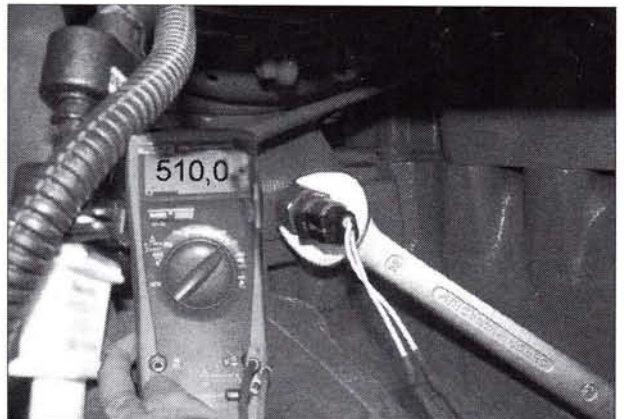

Fig. 20.

1007226

Mark switch relative to the housing

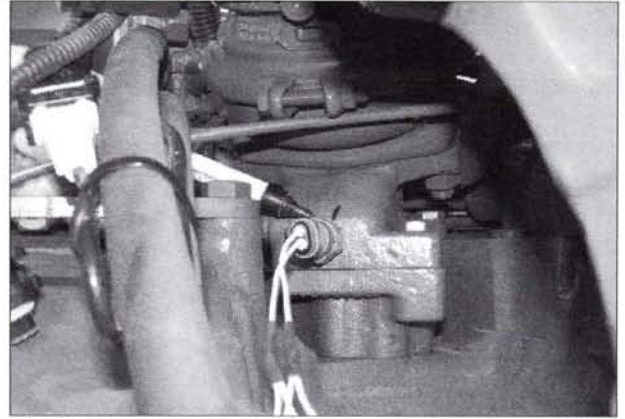

Fig. 21.

I007223

Turn switch back 1 4/6 turns

NOTE: When the switch is turned back, the multimeter will switch back to 120 Ohm

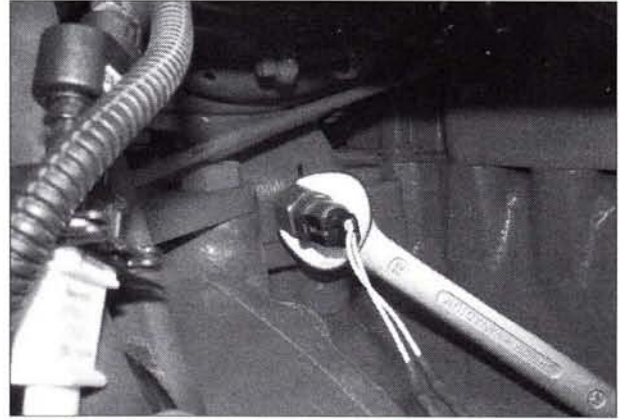

Fig. 22.

I007224