

FENDT

Werkstatthandbuch

Workshopmanual

Manuel d'atelier

Manual de taller

Manuale per l'officina

Werkplaatshandboek

FENDT 900 Vario COM III

X 990.005.057.012

1

FENDT

A	General
B	Faults
C	Documents and Diagrams
D	Component location
E	Testing
F	Setting and Calibration
G	Repair
H	Service – Info

1080

Transmission/drive train

FENDT 900 Vario - COM III

Volume 1

0000	Overall system/tractor
1005	Overall system/transmission
1010	Transmission/differential
1015	Transmission/axle drive
1050	Transmission/housing
1070	Transmission / Brake system
1080	Transmission/drive train
1200	Transmission/front PTO
1220	Transmission / Live PTO
1320	Transmission/front wheel drive
2000	Overall system/engine
2010	Engine/cylinder head
2050	Engine/cooling
2060	Engine/fuel system
2210	Engine/crankcase
2312	Engine/lubrication
2400	Engine/exhaust system
2712	Engine/injectors
3000	Overall system/front axle
3120	Front axle/steering cylinder
3180	Front axle/cardan shaft

Volume 2

4000	Overall system/steering
4090	Steering system / hydraulic steering unit
5030	Vehicle layout/operator's seat
5500	Overall system/air conditioning system
8100	Overall system/cab
8610	Power lift/EPC electro-hydraulic control
8631	Power lift/hydraulic lift
8800	Overall system/compressed air system

Volume 3

9000	Overall system/electrical system
9015	Electrical system/starter lockout

FENDT 900 Vario - COM III

Volume 4

- 9410 Hydraulic pump installation/LS pump
- 9430 Hydraulic pump installation/steering pump
- 9534 Hydraulic piping/"Rüfa"reverse operation
- 9600 Overall system/hydraulic equipment
- 9605 Hydraulic equipment/hydraulic connections
- 9610 Hydraulic equipment/central control block (ZSB)
- 9620 Hydraulic equipment/valve fitting
- 9700 Overall system/electronics
- 9920 Service/special tools
- 9975 Service/SERDIA - Deutz engine diagnostics program

1080 Transmission/drive train

A	General.	5
G	Repair.	9

A General

1	2V3/2V4 high-pressure limiting valve	7
2	2V5 purge valve (function)	8

1 2V3/2V4 high-pressure limiting valve

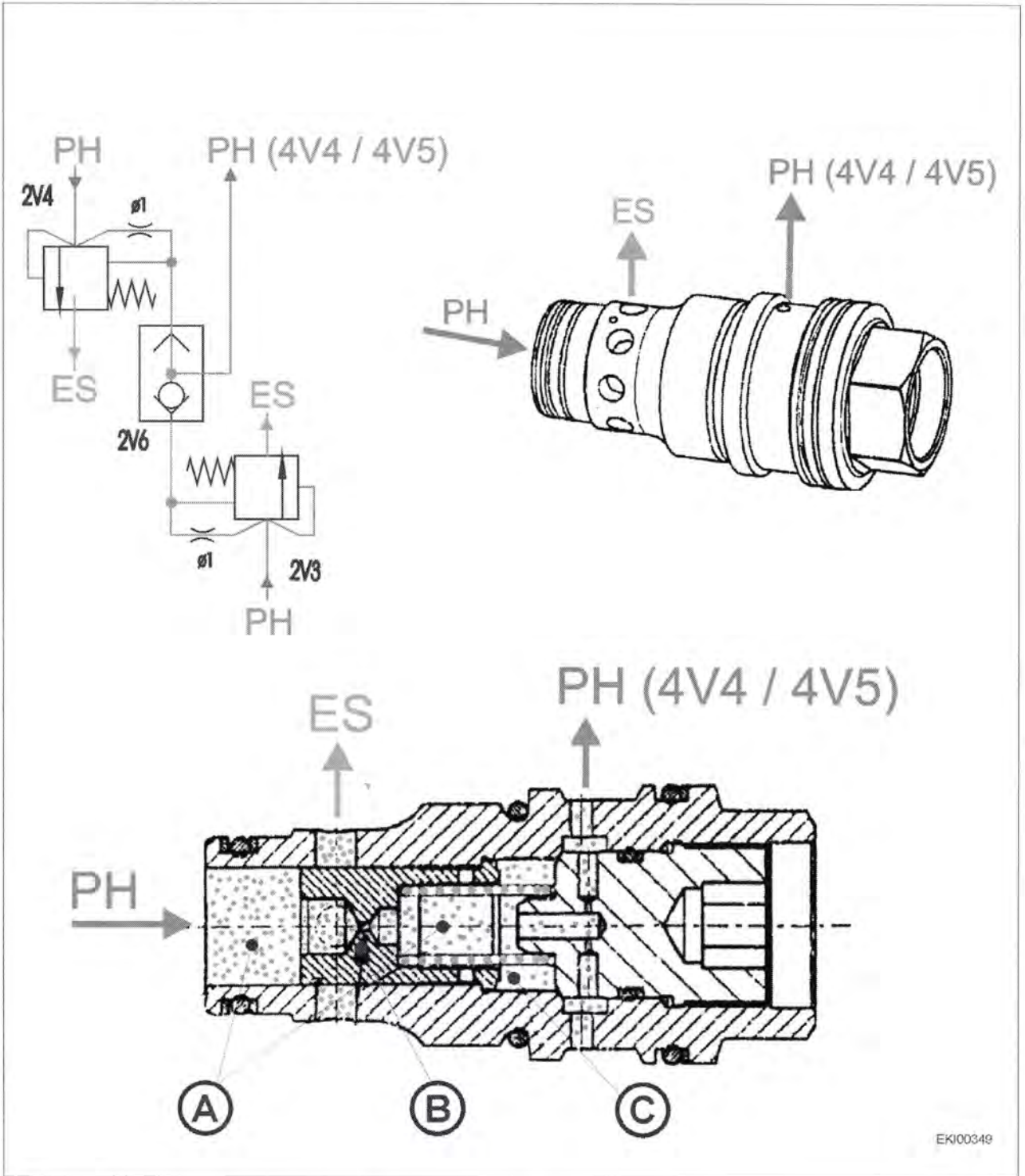

Fig. 1.

I002165

- A If the clutch and turbo-clutch valve is closed, the pressure is equal in both chambers. The spring holds the piston closed.
- B If the clutch or turbo-clutch valve is open, the pressure drop through the diaphragm (x piston surface area) becomes greater than the spring force. The piston moves to the right and connects PH with ES.
- C The pressure is limited by the clutch and turbo-clutch valves.

919 .. 0101-1000	925 .. 1001-	934 .. 0101-1000
919 .. 1001-	928 .. 0101-1000	934 .. 1001-
922 .. 0101-1000	928 .. 1001-	
922 .. 1001-	931 .. 0101-1000	
925 .. 0101-1000	931 .. 1001-	

T000752
Version 2
03-02-2010

2 2V5 purge valve (function)

Pressure at **A, B** max. 550 bar

Pressure at **T** max. 50 bar

Opening pressure: $\Delta p = 7$ bar between **A** and **B**

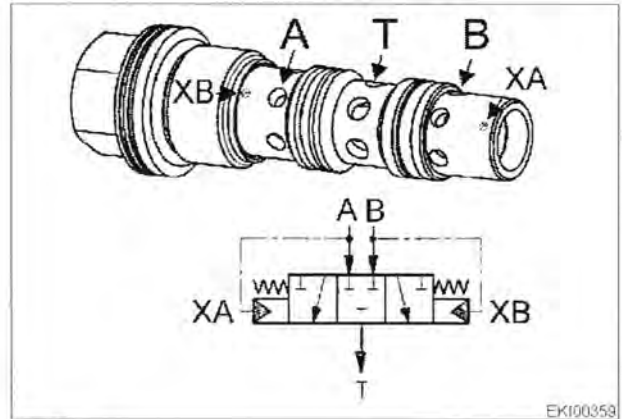

Fig. 2.

EK100359
1002166

Transmission in "neutral"

$p_A = p_B$, $\Delta p < 7$ bar

Piston is held in mid-position by spring force. Both channels (**A, B**) are closed.

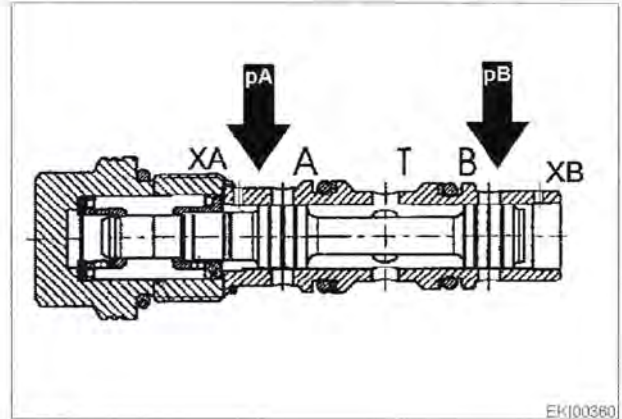

Fig. 3.

EK100360
1002166

"Tractive mode"

$p_A > p_B$, $\Delta p > 7$ bar

Piston is pushed to the right via control bore **XA**.

Channel **B** is connected to **T**. Hot oil can flow from the low pressure side **B** via **T** to the discharge connection and to the oil cooler.

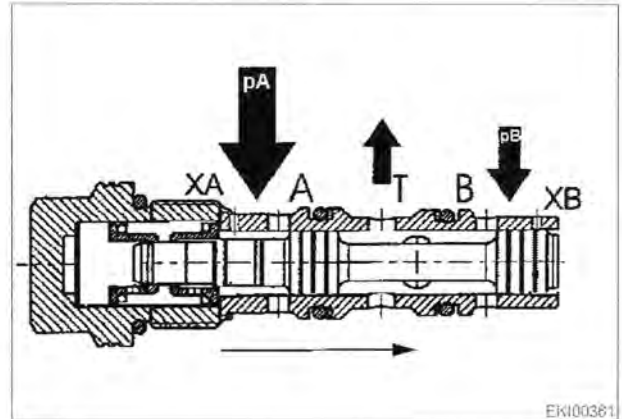

Fig. 4.

EK100361
1002168

"Pushing mode"

$p_A < p_B$, $\Delta p > 7$ bar

Piston is pushed to the left via control drilling **XB**.

Channel **A** is connected to **T**. Hot oil can flow from the low pressure side **A** via **T** to the discharge connection and to the oil cooler.

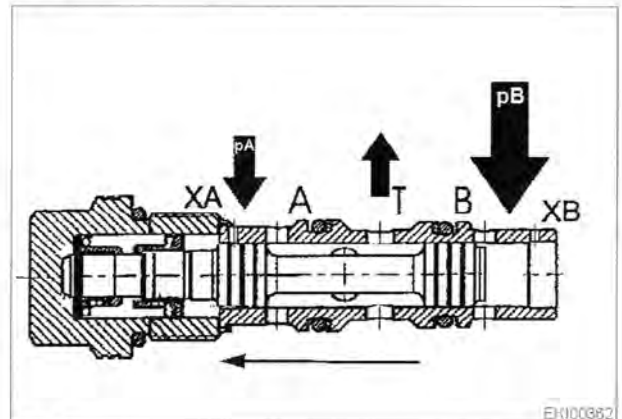

Fig. 5.

EK100362
1002169

G Repair

1	Dismantling the continuous drive train	11
2	Fit the continuous drive train	20
3	Installing A009 actuator unit.	30
4	Replacing high-pressure limiting valve	34
5	Replacing the purge valve	35
6	Top up the transmission oil	36

1 Dismantling the continuous drive train

Preliminary work:

- Remove rear wheels
- Remove cover panels
- see §1

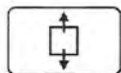

Drain transmission oil.

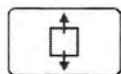

Loosen compressed air bracket

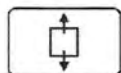

Remove the left hand fuel tank retaining strap



Fig. 1.

1001718

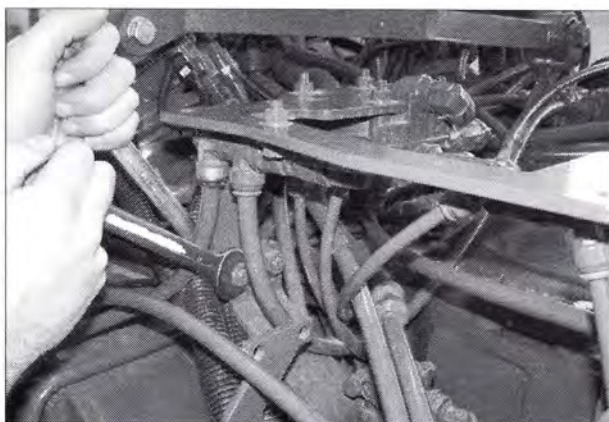

Fig. 2.

1001811



Fig. 3.

1001812

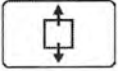

Unscrew the retaining strap bracket

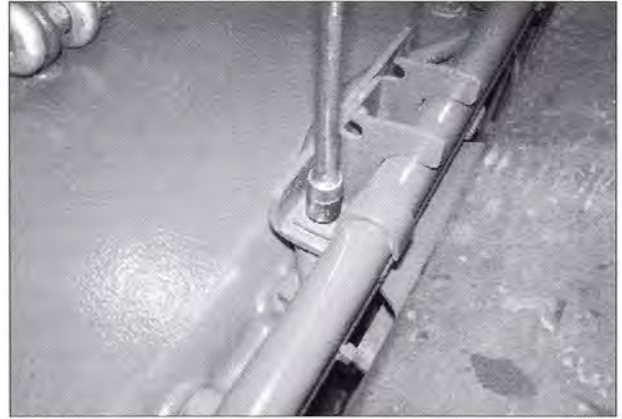
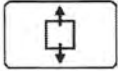

Fig. 4.

1001813



Push the bracket to the side and remove

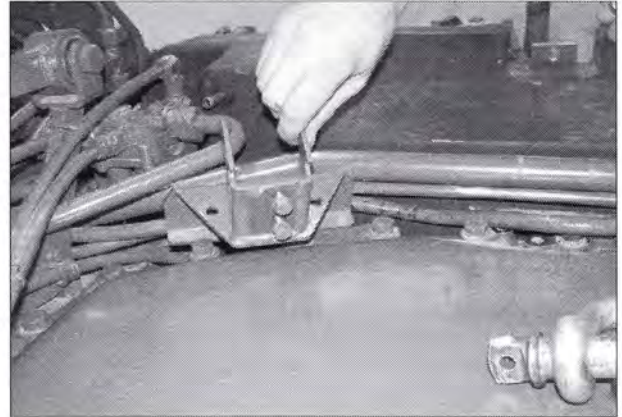
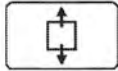

Fig. 5.

1001815



Remove the housing cover screws



Fig. 6.

1001814

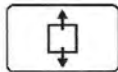

Carefully take the weight of the housing cover and raise it



DANGER: Do not walk or stand under suspended loads!



Fig. 7.

1001816

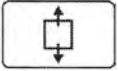

Remove the actuator unit

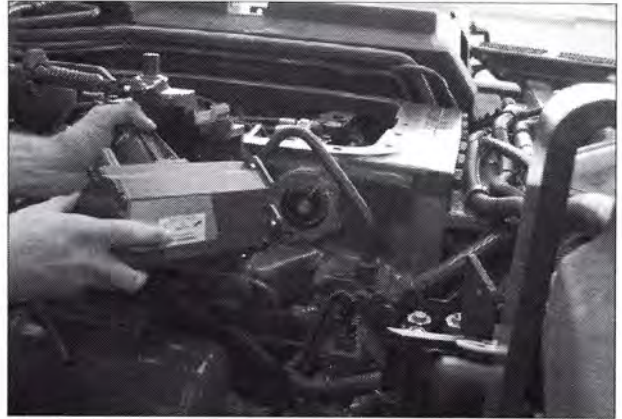
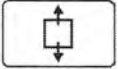

Fig. 8.

I001818



Remove the plug on the transmission valve block solenoid valves

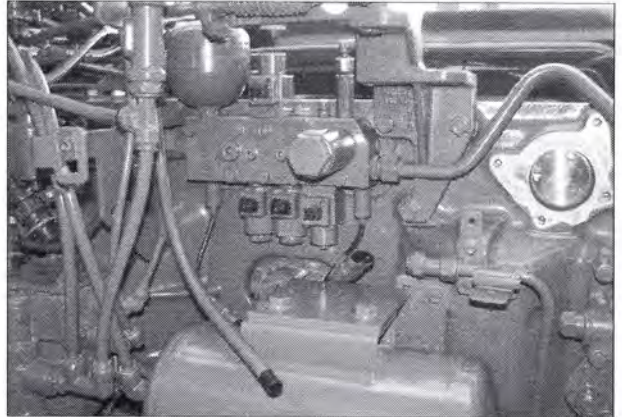
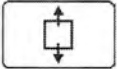

Fig. 9.

I001819



Remove the hydraulic piping between the valve block and the valve housing

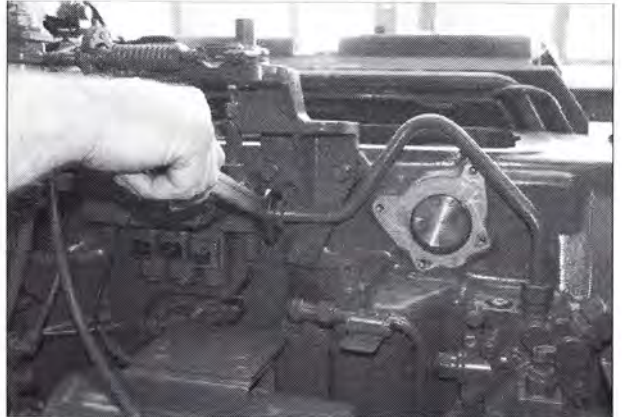
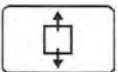

Fig. 10.

I001820



Loosen the coolant piping on the valve housing

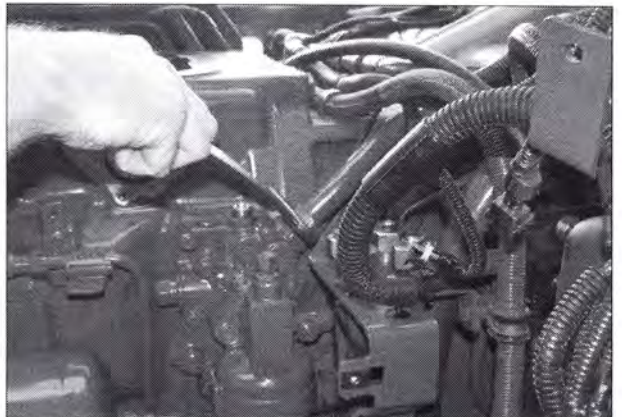

Fig. 11.

I001822

919 .. 0101-1000
 919 .. 1001-
 922 .. 0101-1000
 922 .. 1001-
 925 .. 0101-1000

925 .. 1001-
 928 .. 0101-1000
 928 .. 1001-
 931 .. 0101-1000
 931 .. 1001-

934 .. 0101-1000
 934 .. 1001-

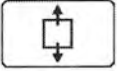

Loosen the pipe clamps

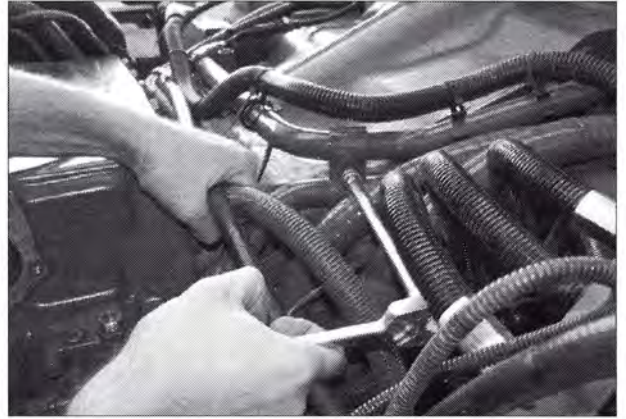
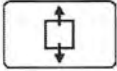

Fig. 12.

1001824



Loosen the hydraulic piping to the hydraulic oil cooler on the engine and remove the piping

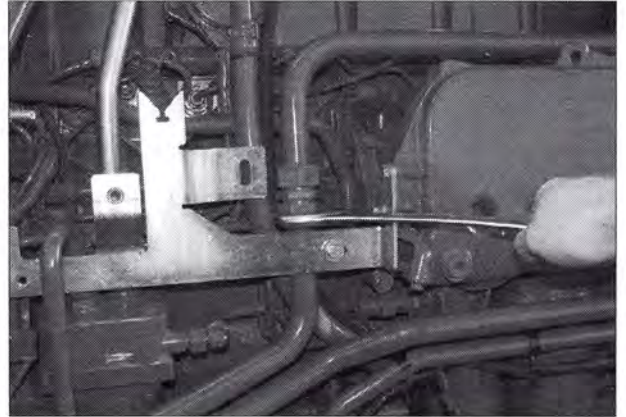
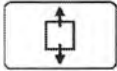

Fig. 13.

1001825



Remove the valve block

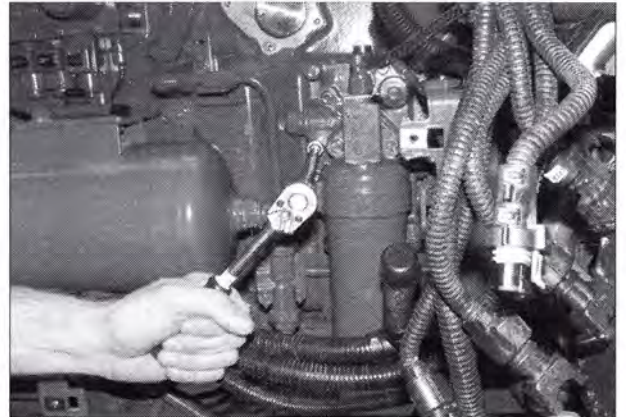
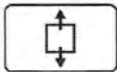

Fig. 14.

1001823



Unscrew the emergency actuation unit



Fig. 15.

1001826

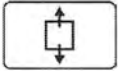

Loosen the transmission valve block retaining screws

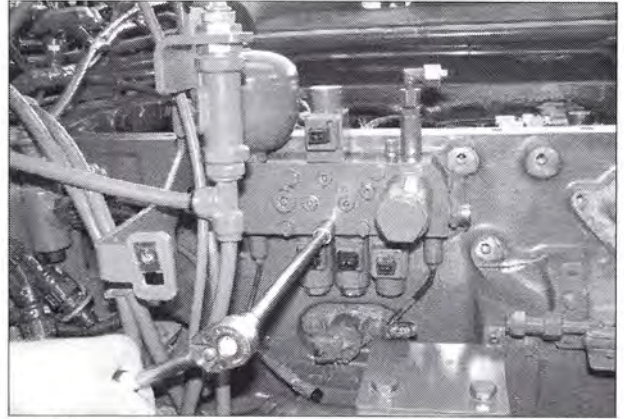
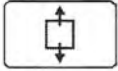

Fig. 16.

1001827



Remove the transmission valve block

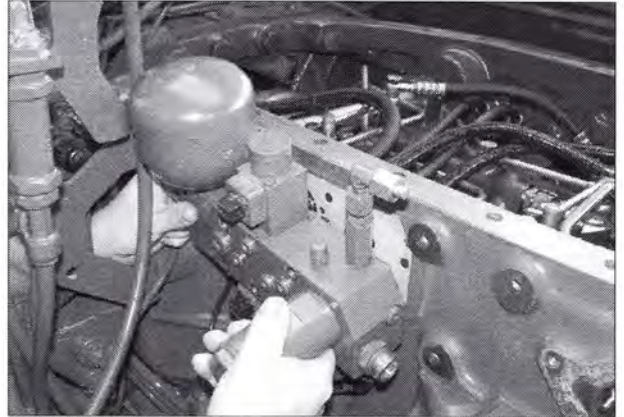
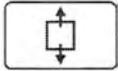

Fig. 17.

1001828



Unclip the securing rings and press the hydraulic piping inwards
Separate the steel piping

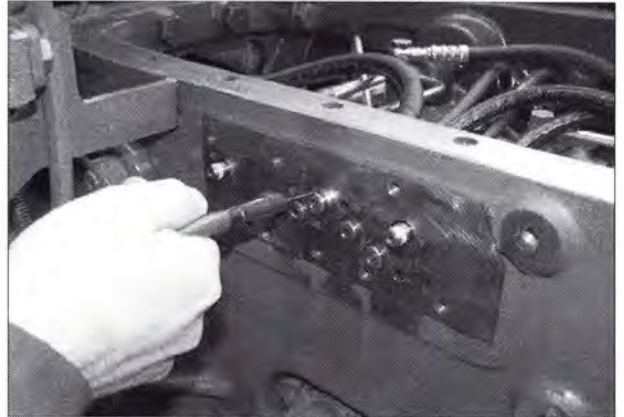
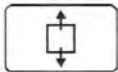

Fig. 18.

1001829



Unclip all circlips and press hose piping inwards.

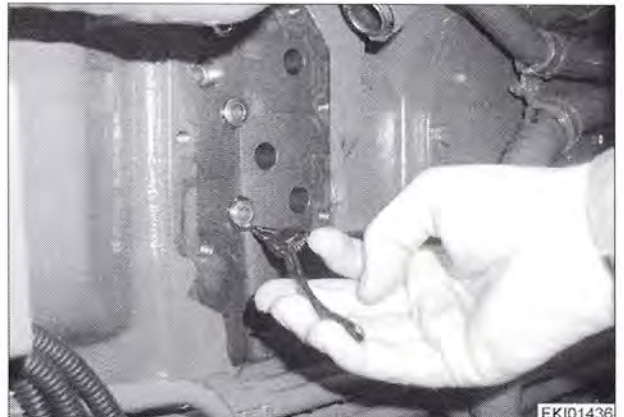

Fig. 19.

EKI01436
1002827

919 .. 0101-1000
919 .. 1001-
922 .. 0101-1000
922 .. 1001-
925 .. 0101-1000

925 .. 1001-
928 .. 0101-1000
928 .. 1001-
931 .. 0101-1000
931 .. 1001-

934 .. 0101-1000
934 .. 1001-

T000666
Version 1
07-11-2007

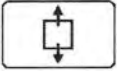

Dismantle sensor, collecting shaft

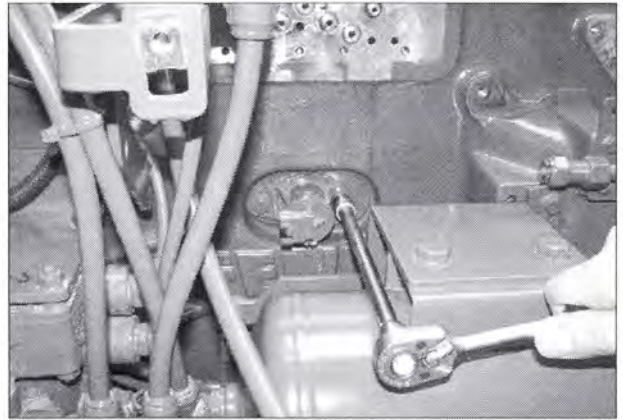
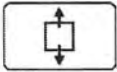

Fig. 20.

I001830



Dismantle sensor, bevel pinion

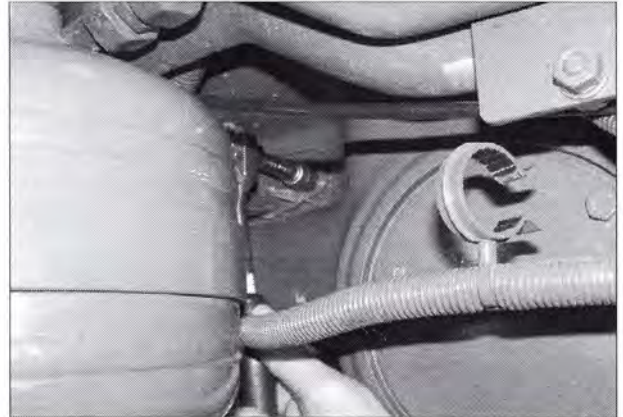
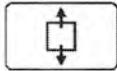

Fig. 21.

I001831



Unscrew the stud bolt and withdraw the actuator shaft

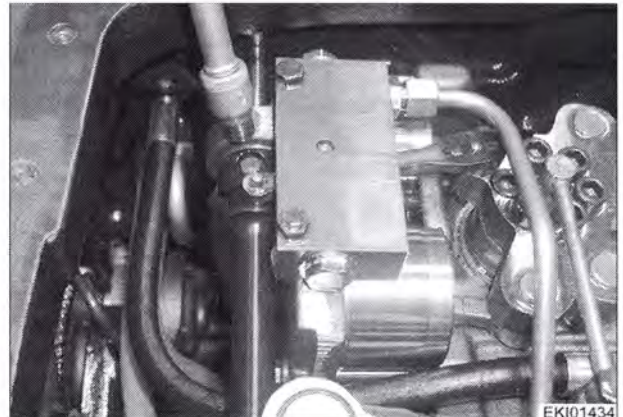
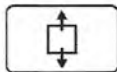

Fig. 22.

EKI01434
I002826



Remove the hydraulic hose (enhanced switching pressure supply)

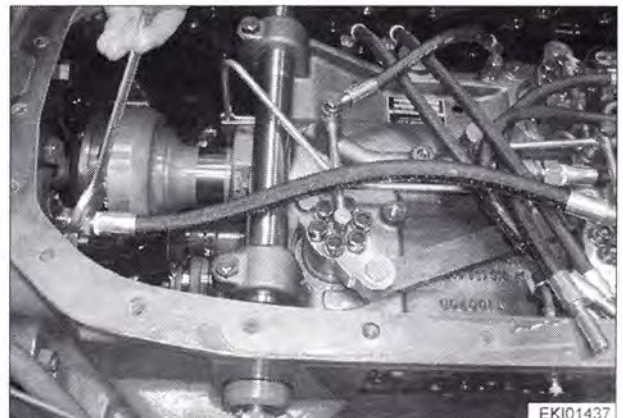
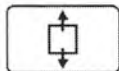

Fig. 23.

EKI01437
I002828



Unclip the drive shaft securing ring and push it to the rear

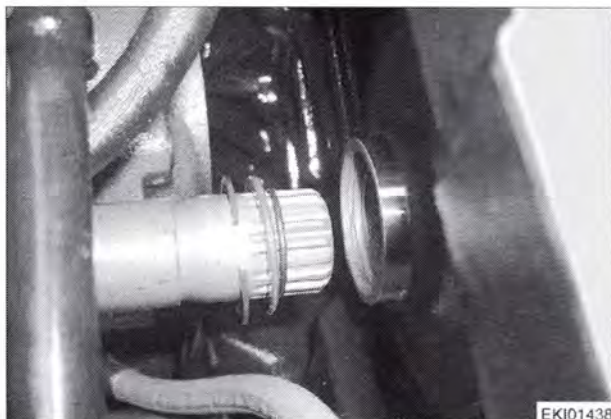
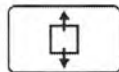

Fig. 24. EKI01438
1002829



Remove three M8 hex. screws from the planetary gear and push the drive shaft to the rear



Fig. 25. EKI01439
1002830

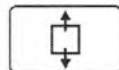

Unclip the securing ring on the pinion shaft
Push the securing ring, washer and sleeve onto the bevel pinion in the direction of the arrow

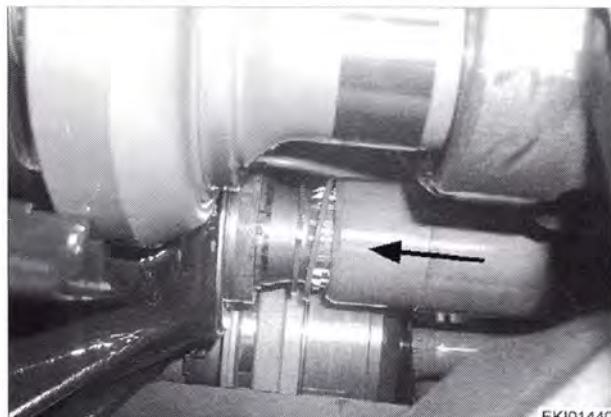
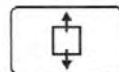

Fig. 26. EKI01440
1002831



Using the fitting lever swing the hydraulic motors inwards

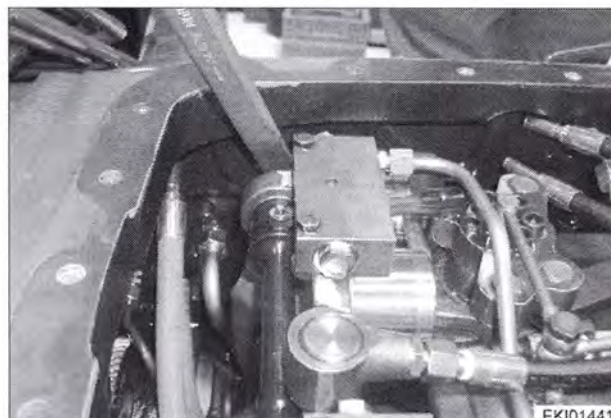
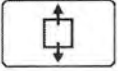

Fig. 27. EKI01441
1002833

919 .. 0101-1000
919 .. 1001-
922 .. 0101-1000
922 .. 1001-
925 .. 0101-1000

925 .. 1001-
928 .. 0101-1000
928 .. 1001-
931 .. 0101-1000
931 .. 1001-

934 .. 0101-1000
934 .. 1001-



Remove the hex. nuts from the bearings

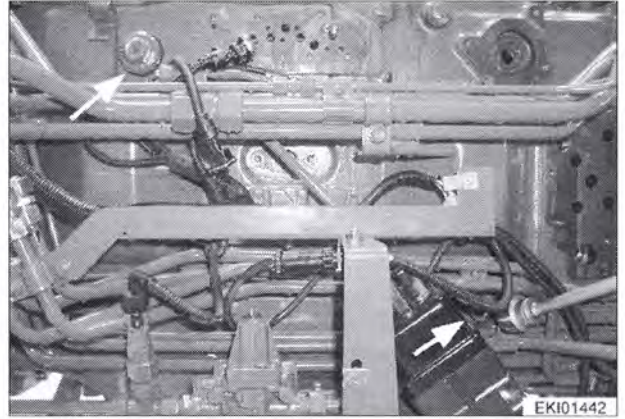
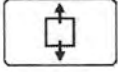

Fig. 28.

EKI01442
I002834



Loosen the upper locking screws M12
Remove the two screw plugs on the under side of the transmission housing
Collect any escaping oil.
Loosen the two locking screws M12 as above

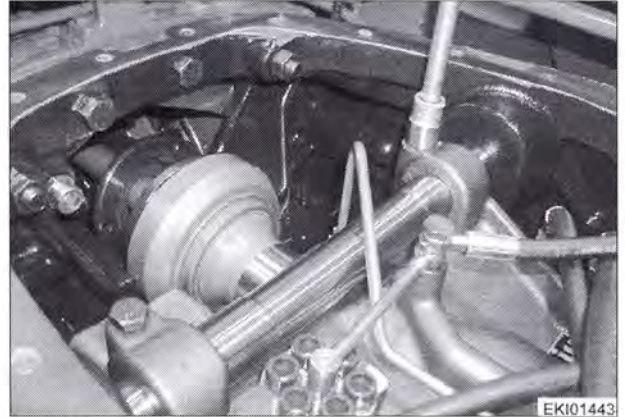
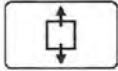

Fig. 29.

EKI01443
I002835



Fit the hoisting gear
Insert the lifting hooks and slightly tension



Fig. 30.

EKI01444
I002836

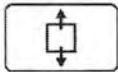

Screw on the slide hammer puller with adapted M20 nut (self made)
Remove shafts for elastic pivot
Remove upper shaft first

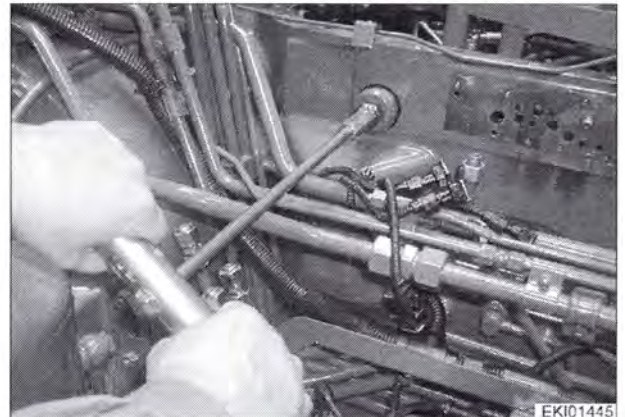
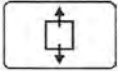

Fig. 31.

EKI01445
I002837



Raise transmission unit carefully out of transmission housing using hoist
 Ensure clearance of all components!

! DANGER: Do not walk or stand under suspended loads!

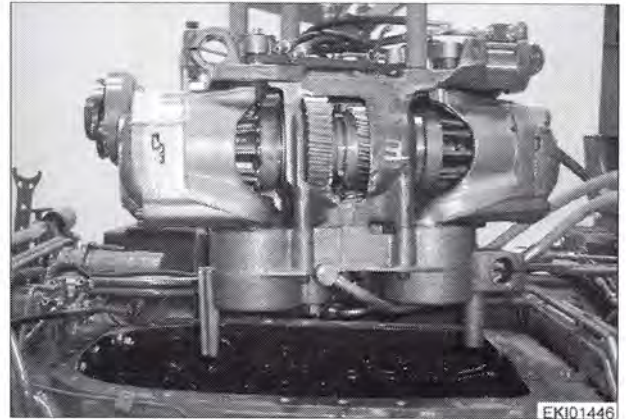
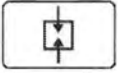

Fig. 32.

EK101446
 I002838

2 Fit the continuous drive train



Attach transmission unit to hoist, taking appropriate safety precautions.
Set travel range control I-II (arrowed) to neutral (middle)

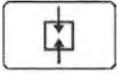

Clean sealing surfaces on transmission housing to remove oil and seal residue.
Set the change lever (arrowed) of the travel range control I-II in the transmission housing to neutral (middle)

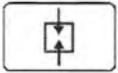

Where removed:
Fit the circlip and washer to the pinion shaft splines, push the sleeve onto the pinion shaft as far as it will go
Locate the flange on the connection shaft and fit connection shaft.

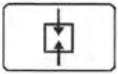

Insert the ML drive into the transmission housing. Ensure clearance for all components.
Fit both shafts into the transmission housing bores and fit the transmission unit

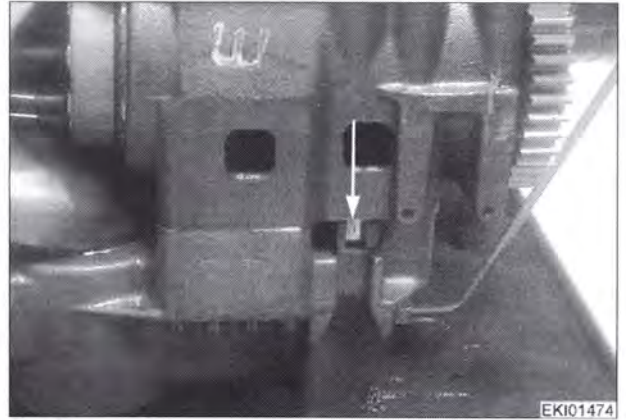

Fig. 33.

EKI01474
1002893

Fig. 34.

EKI01449
1002877

Fig. 35.

EKI01450
1002878

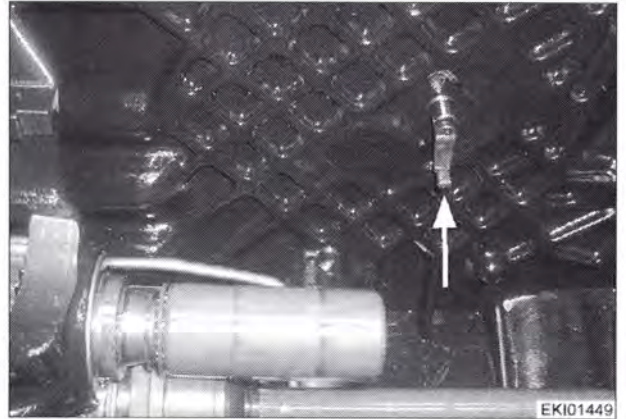
Fig. 36.

EKI01451
1002879

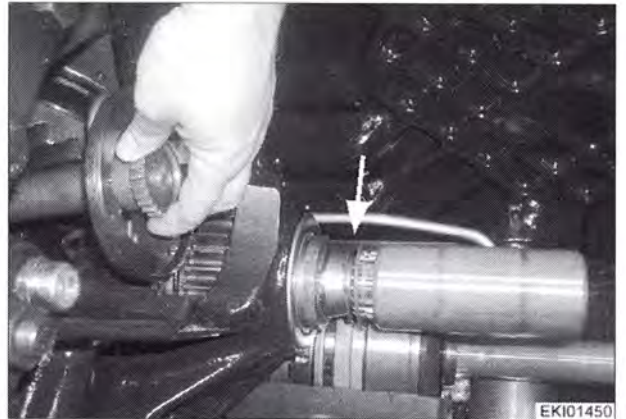

Check the bushes for wear and, if necessary, use new bushes
Insert four bushes into bores as far as they will go

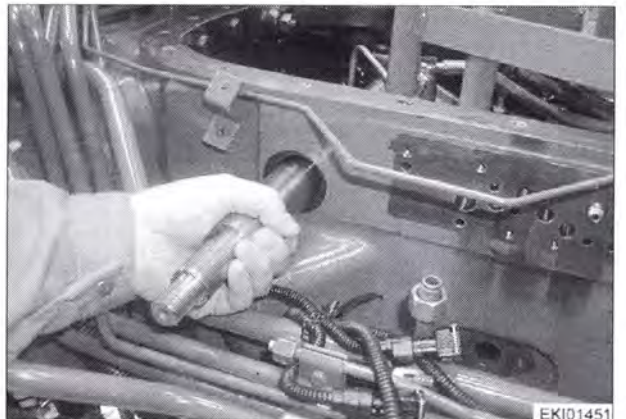
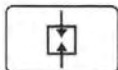

Fig. 37.

EKI01452
1002880

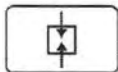

Fit the rings to the left and right as appropriate to the shaft, with the cut-out towards the bushing
Screw on the M20 nuts



Fig. 38.

EKI01453
1002881

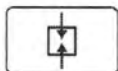

Tighten the four M20 nuts
Torque: 250 Nm

NOTE: When tightening each of the nuts, hold the second nut on the shaft against it

Remove the hoist

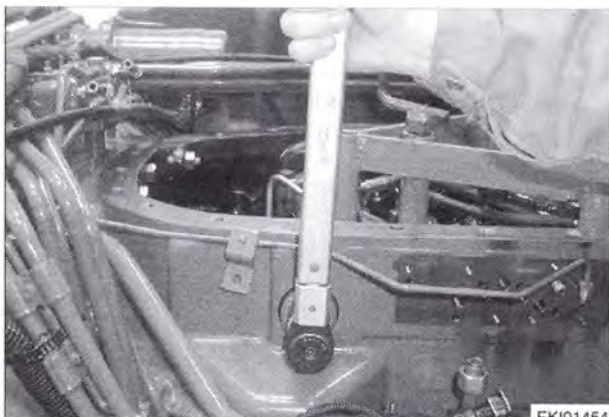
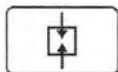

Fig. 39.

EKI01454
1002882



Turn one of the planet wheels of the power distribution planetary gear upwards

Using a feeler gauge, centralise the transmission unit (same play to left and right)



Fig. 40.

EKI01455
1002883

919 .. 0101-1000
919 .. 1001-
922 .. 0101-1000
922 .. 1001-
925 .. 0101-1000

925 .. 1001-
928 .. 0101-1000
928 .. 1001-
931 .. 0101-1000
931 .. 1001-

934 .. 0101-1000
934 .. 1001-

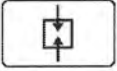

Tighten all four securing screws (two above, two be-
neath)
Torque: 86 Nm
Using new seals, fit both screw plugs to the underside of
the transmission housing
Switch through travel range control I-II

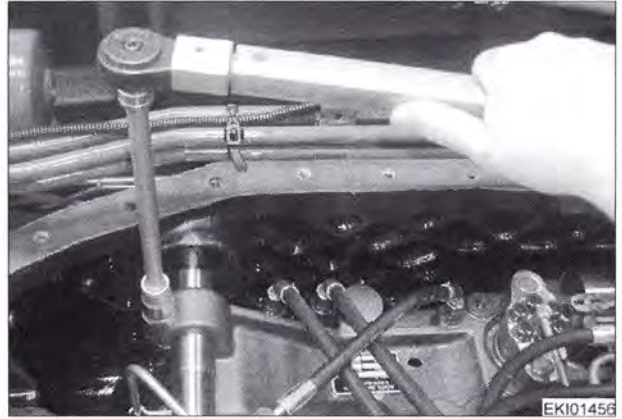
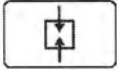

Fig. 41.

EKI01456
1002884



Turn ML transmission until one tooth of the gear plate is
in line with the bore for the Hall sensor

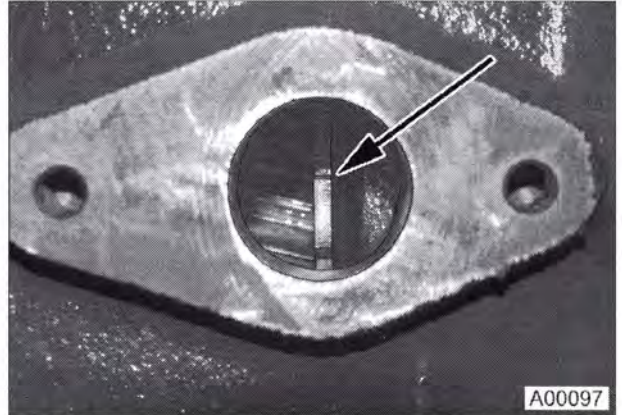
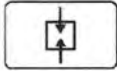

Fig. 42.

A00097

1002894



Coat sealing surface of Hall sensor with X
903.050.553.000 sealant and insert into the transmission
housing bore.
Tighten screws, torque: 25 Nm



Fig. 43.

A00101

1002895

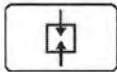

Swing out the hydraulic motor as far as possible

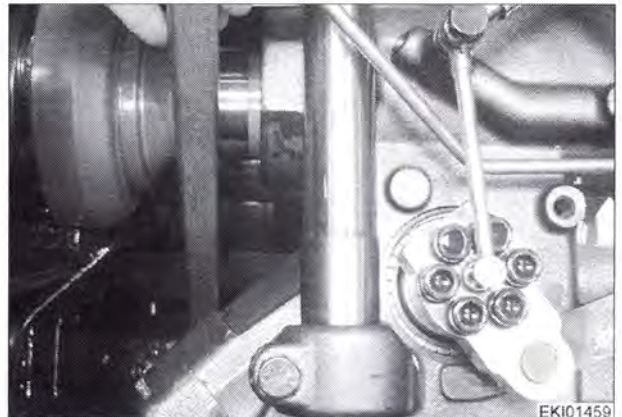
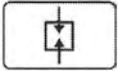

Fig. 44.

EKI01459
1002885



Slide the sleeve on the pinion shaft forwards until the groove for the circlip is uncovered
Clip circlip into groove

NOTE: If the sleeve is not aligned, jack up one of the front wheels and turn it

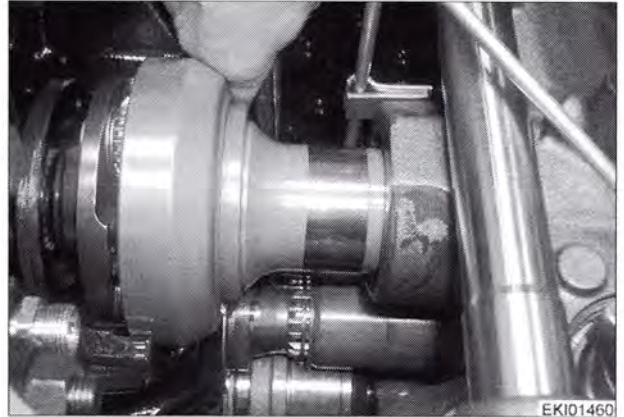
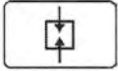

Fig. 45.

EKI01460
1002886



Mount flange on planetary gear of the power distribution system
Tighten the M8 hex. bolts
Torque: 25 Nm

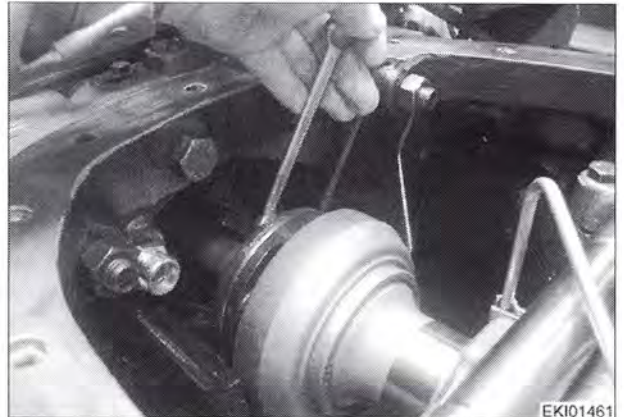
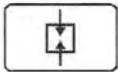

Fig. 46.

EKI01461
1002887

- 1 Short blue hose (discharge)
- 2 Long blue hose (feed)
- 3 Black hose (lubrication)



Insert the hydraulic hoses into the transmission housing bores and fit the circlips (opening downwards)

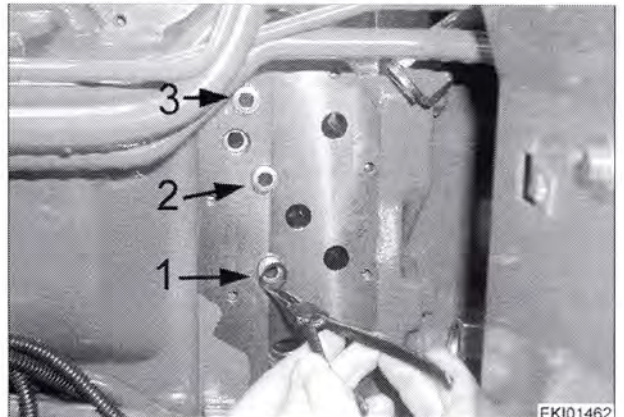
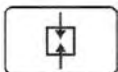

Fig. 47.

EKI01462
1002888



Place the snap ring into the groove in the shaft, push the shaft forwards and fit the washer
Fit the circlip into the groove in the spur gear

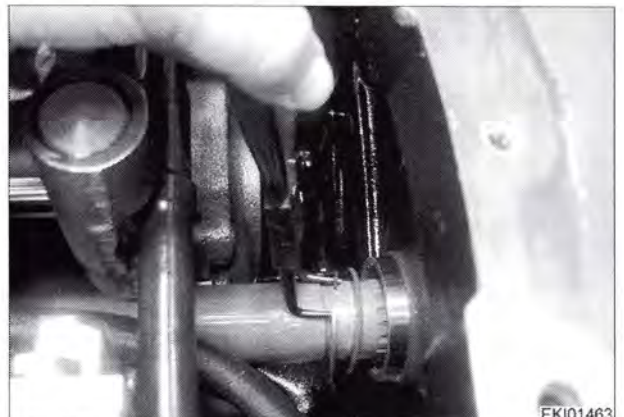
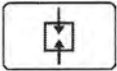

Fig. 48.

EKI01463
1002889

919 .. 0101-1000	925 .. 1001-	934 .. 0101-1000
919 .. 1001-	928 .. 0101-1000	934 .. 1001-
922 .. 0101-1000	928 .. 1001-	
922 .. 1001-	931 .. 0101-1000	
925 .. 0101-1000	931 .. 1001-	



Fit the hydraulic hose (enhanced switching pressure supply)

- 1 High-pressure reverse sensor lines
- 2 System pressure, rear axle
- 3 Switching pressure, travel range I
- 4 Speed governor
- 5 Switching pressure, travel range II
- 6 System pressure
- 7 Control line for high-pressure limiting valves

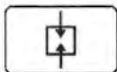

Insert the pressure hoses in the transmission housing bores

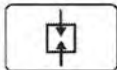

Fitting the circlips

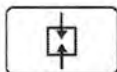

Clean the sealing surfaces of the valve block and the housing, attach a new seal with a small amount of grease to the transmission housing, insert new O-rings and fit the valve block

Tighten the securing bolts

Torque: 25 Nm

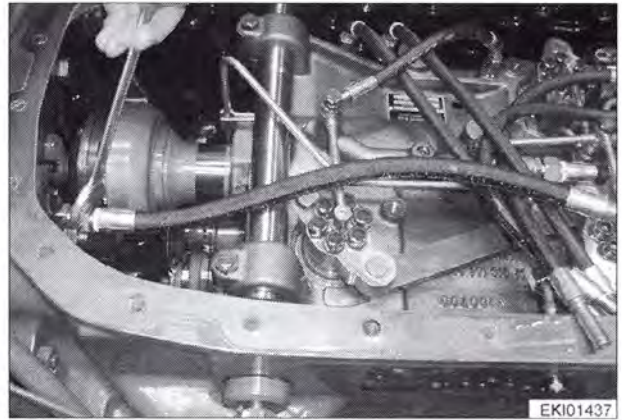

Fig. 49.

EKI01437
1002828

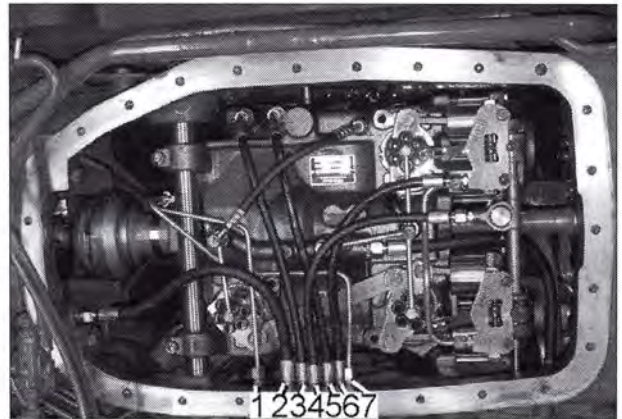

Fig. 50.

1002906

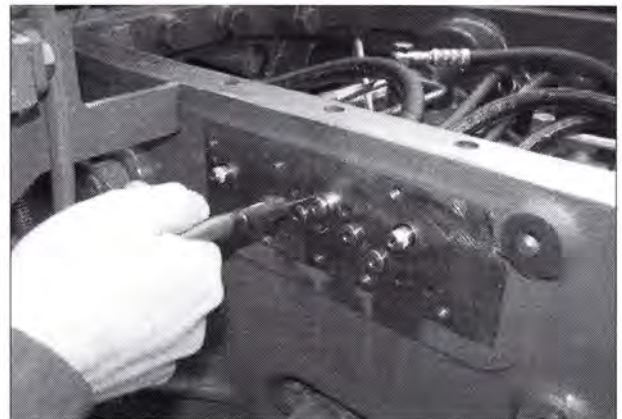

Fig. 51.

1001829

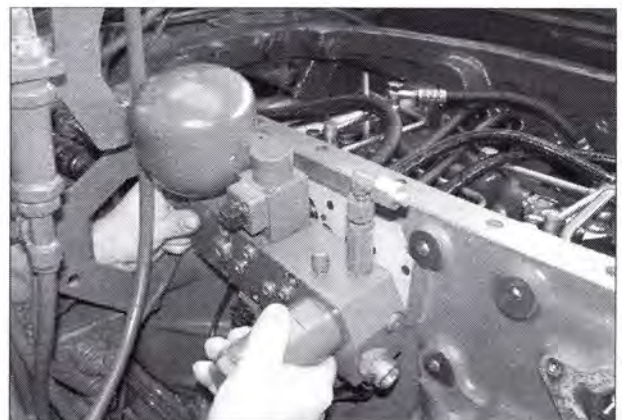
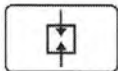

Fig. 52.

1001828



Place new O-rings into the valve housing with a small amount of grease and tighten the securing bolts
Torque: 25 Nm

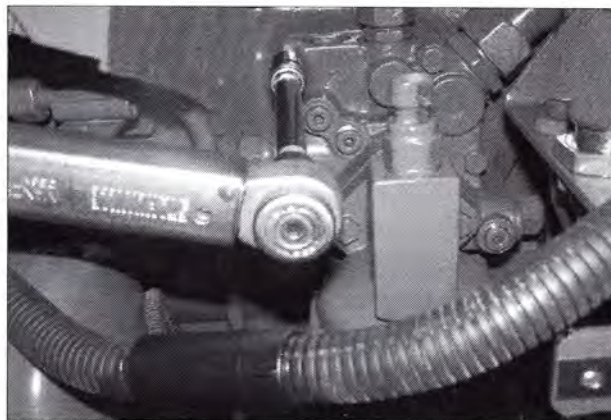
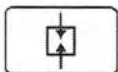

Fig. 53.

I002900



If necessary, fit the new shaft sealing ring and fill 2/3 with grease
Fit the actuator shaft

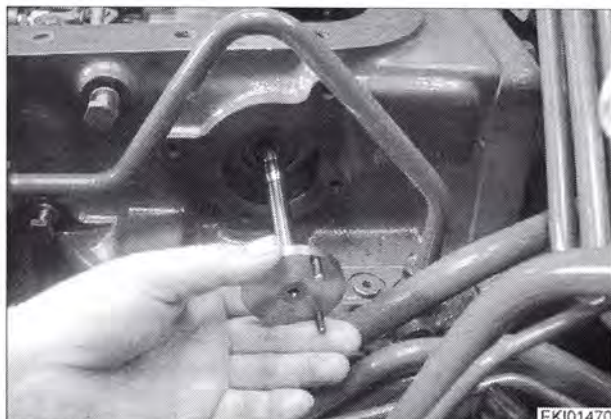
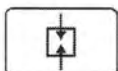

Fig. 54.

EKI01470
I002896



Mate the depression in the actuator shaft with the threaded bore.

NOTE: Coat the threads of the hex. screw with thread-lock compound and tighten to a torque of 25 Nm

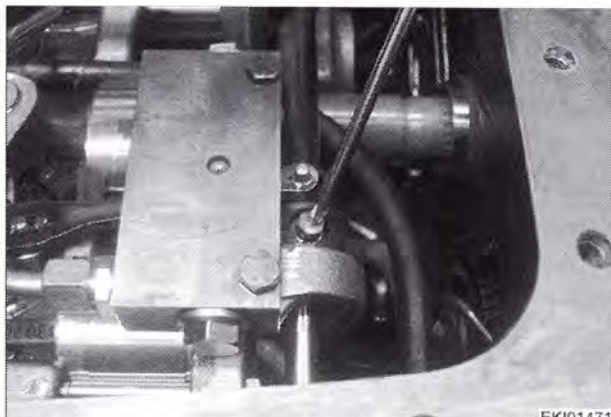
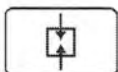

Fig. 55.

EKI01471
I002897



Fit the emergency actuation unit



Fig. 56.

I001826

919 .. 0101-1000
919 .. 1001-
922 .. 0101-1000
922 .. 1001-
925 .. 0101-1000

925 .. 1001-
928 .. 0101-1000
928 .. 1001-
931 .. 0101-1000
931 .. 1001-

934 .. 0101-1000
934 .. 1001-

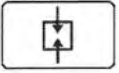

Fit the coolant piping and tighten the screw coupling on the engine

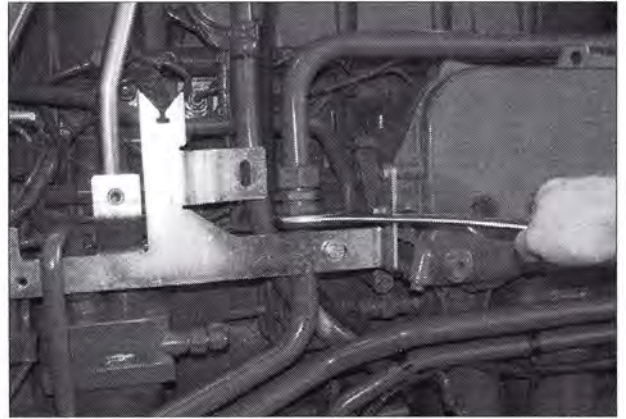
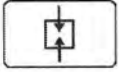

Fig. 57.

1001825



Tighten the coolant piping on the valve housing

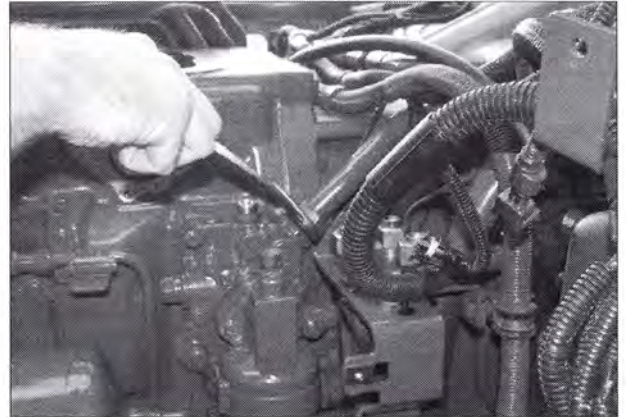
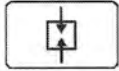

Fig. 58.

1001822



Tighten the piping clamps

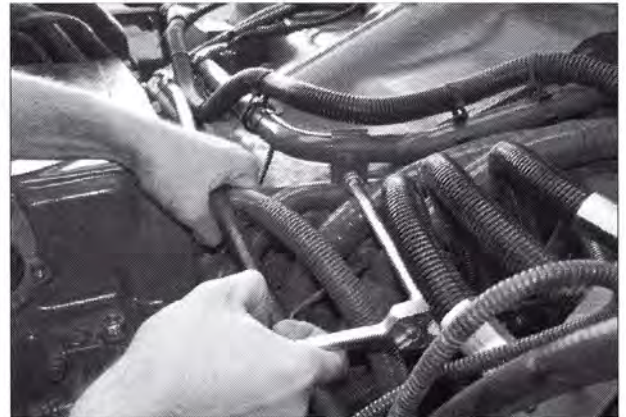
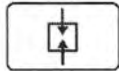

Fig. 59.

1001824



Fit the hydraulic piping between the valve block and the valve housing

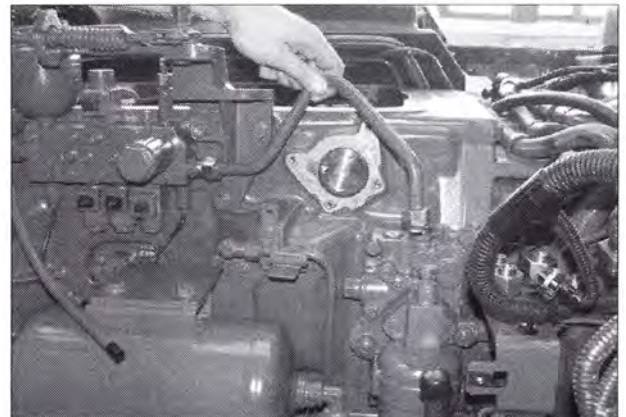
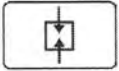

Fig. 60.

1001821



Tighten the hydraulic piping

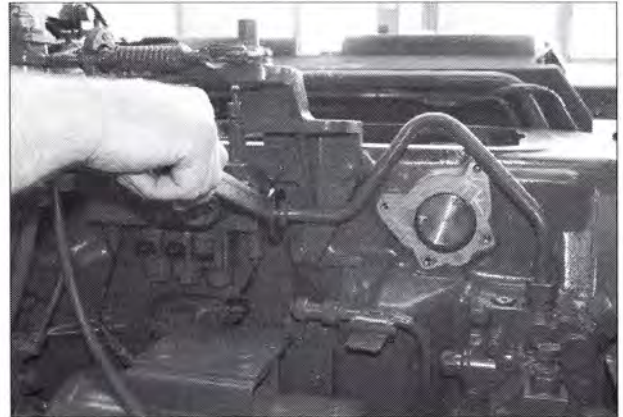
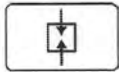

Fig. 61.

I001820



Fit the actuator unit and tighten the hex. socket head screws
 Torque: 25 Nm

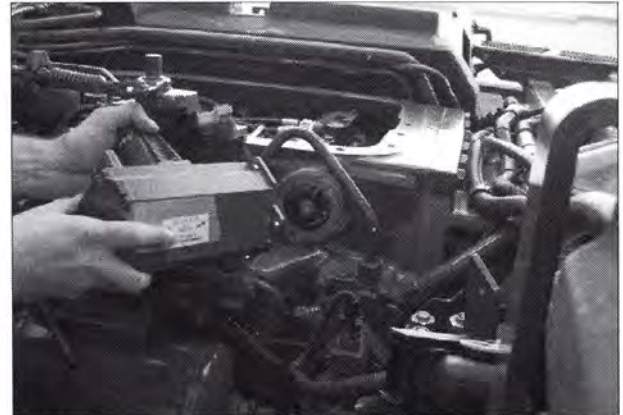
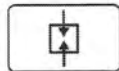

Fig. 62.

I001818



Fit the screw plugs on the underside of the transmission housing



Fig. 63.

I001718

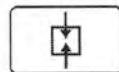

Unscrew the plug to the PU connection
 Connect the external oil filler
 Observe instructions for oil type and quantity

NOTE: During the filling process, pivot the hydraulic pumps and hydraulic motors by turning the actuator shaft.
 Monitor the visible hydraulic connections for leaks.

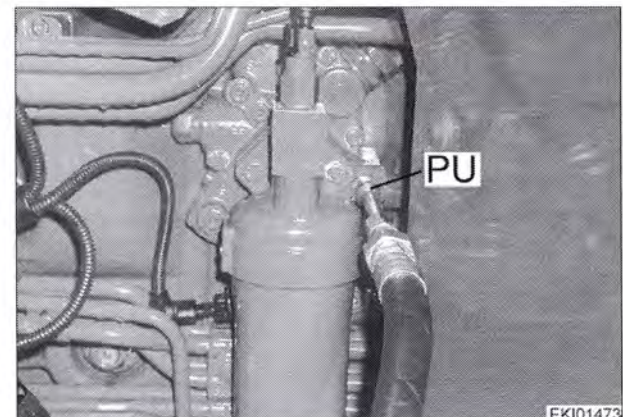
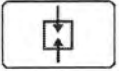

Fig. 64.

EKI01473
 I002899

919 .. 0101-1000	925 .. 1001-	934 .. 0101-1000
919 .. 1001-	928 .. 0101-1000	934 .. 1001-
922 .. 0101-1000	928 .. 1001-	
922 .. 1001-	931 .. 0101-1000	
925 .. 0101-1000	931 .. 1001-	



Coat the clean sealing surfaces evenly with X903.050.074 sealing compound
Carefully raise the transmission housing cover and fit it

! DANGER: Do not walk or stand under suspended loads!

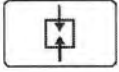

Tighten the housing cover bolts
Torque: 120 Nm

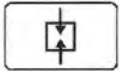

Pass the bracket of the retaining strap underneath the hydraulic piping and slide the bracket sideways into position

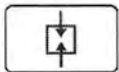

Tighten the bracket bolts



Fig. 65.

1001816

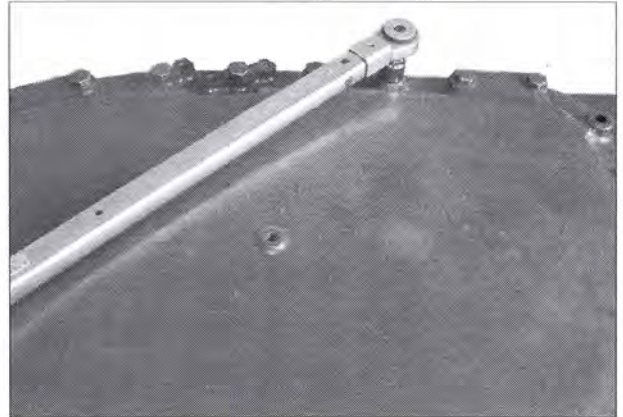

Fig. 66.

1002901

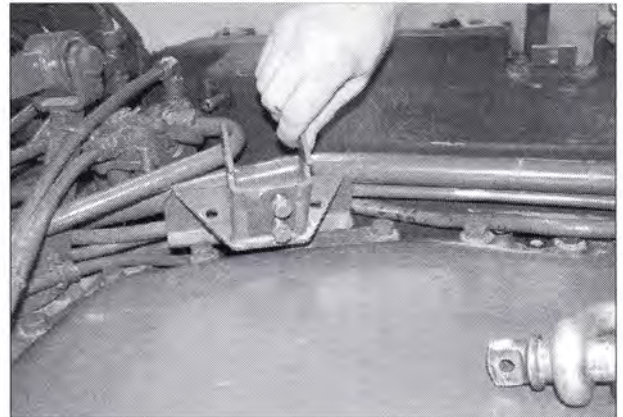

Fig. 67.

1001815



Fig. 68.

1001813

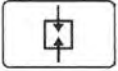

Fit the left fuel tank retaining strap and tighten the nut

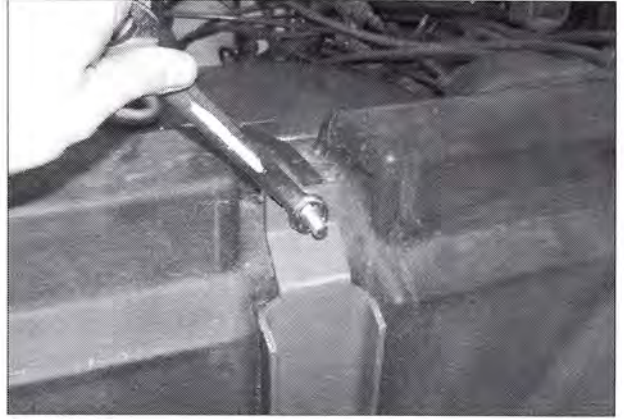
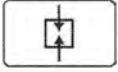

Fig. 69.

I001812



Fit the compressed air bracket and tighten the bolts

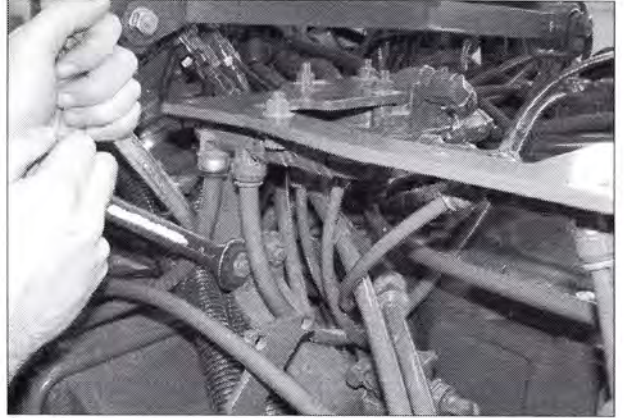

Fig. 70.

I001811

Final procedures:

- see §6
- see §2

3 Installing A009 actuator unit

A009 actuator unit

X037 separation point on actuator unit



On the right side of the transmission

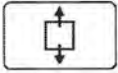

Remove right rear wheel.
Remove metal panel

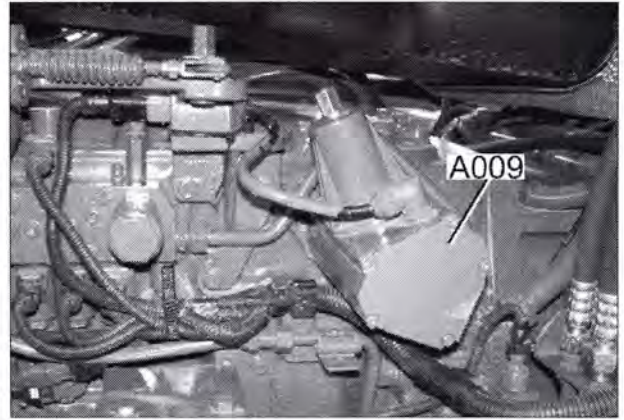

Fig. 71.

I001024

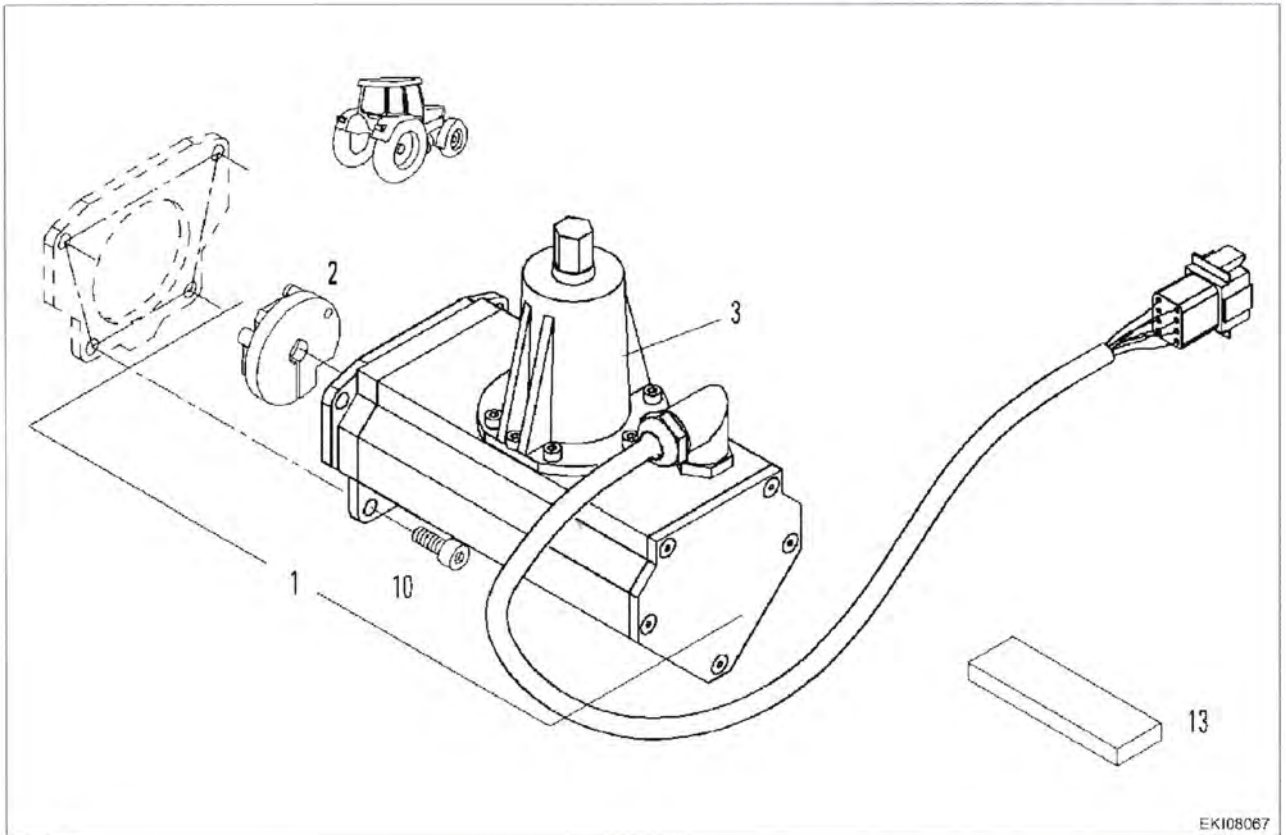
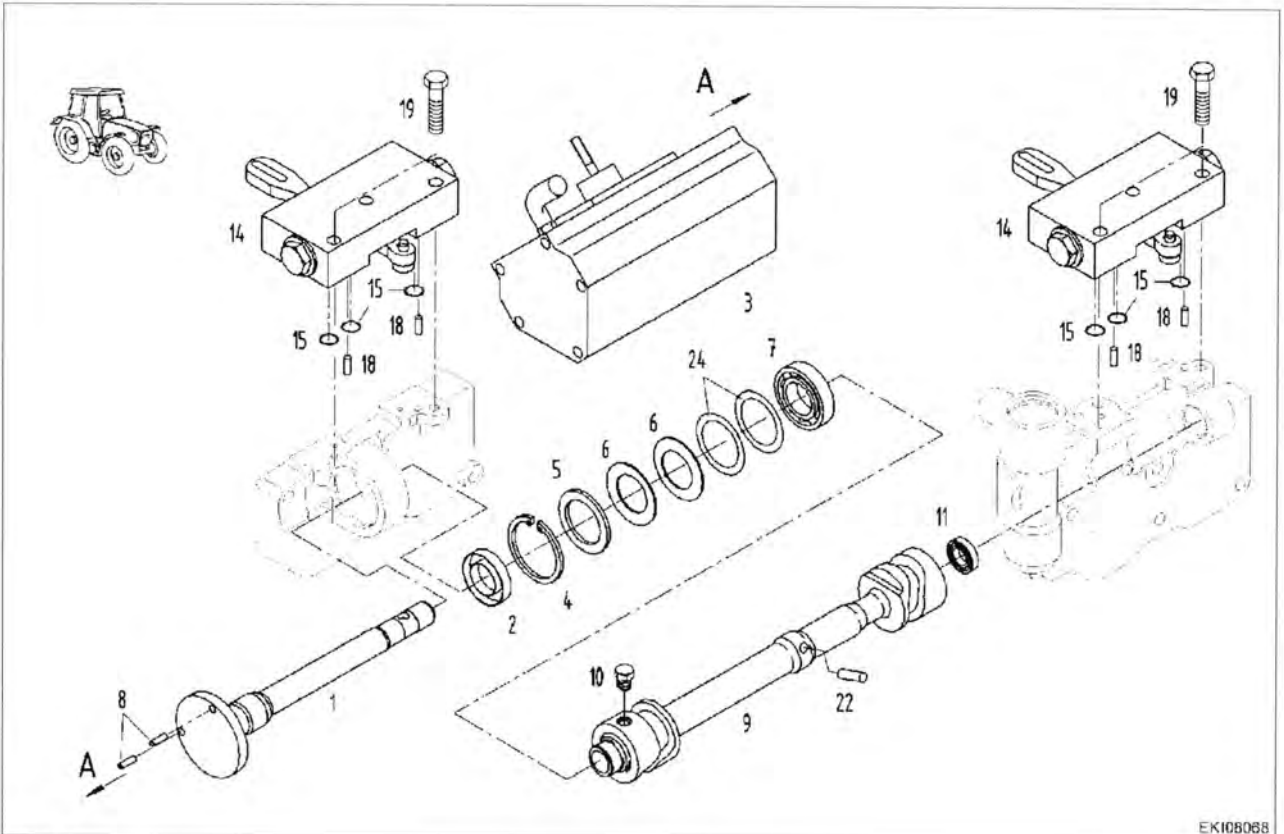

Fig. 72.

EKI08067

I000691

Item	Designation	Item	Designation
1	A009 actuator unit	10	Socket head cap screw
2	Clutch	13	Sealing strip
3	Dome		



EK108068

Fig. 73.

1000690

Item	Designation	Item	Designation
1	Shaft	10	Hex screw
2	Shaft seal ring	11	Deep-groove ball bearing
3	A009 actuator unit	14	Governor
4	Circlip	15	O-ring
5	Locating ring	18	Dowel pin
6	Belleville spring	19	Hex screw
7	Deep-groove ball bearing	22	Parallel pin
8	Pin	24	Shim pack
9	Actuator shaft		

919 .. 0101-1000
919 .. 1001-
922 .. 0101-1000
922 .. 1001-
925 .. 0101-1000

925 .. 1001-
928 .. 0101-1000
928 .. 1001-
931 .. 0101-1000
931 .. 1001-

934 .. 0101-1000
934 .. 1001-

T002583
Version 1
21-04-2009

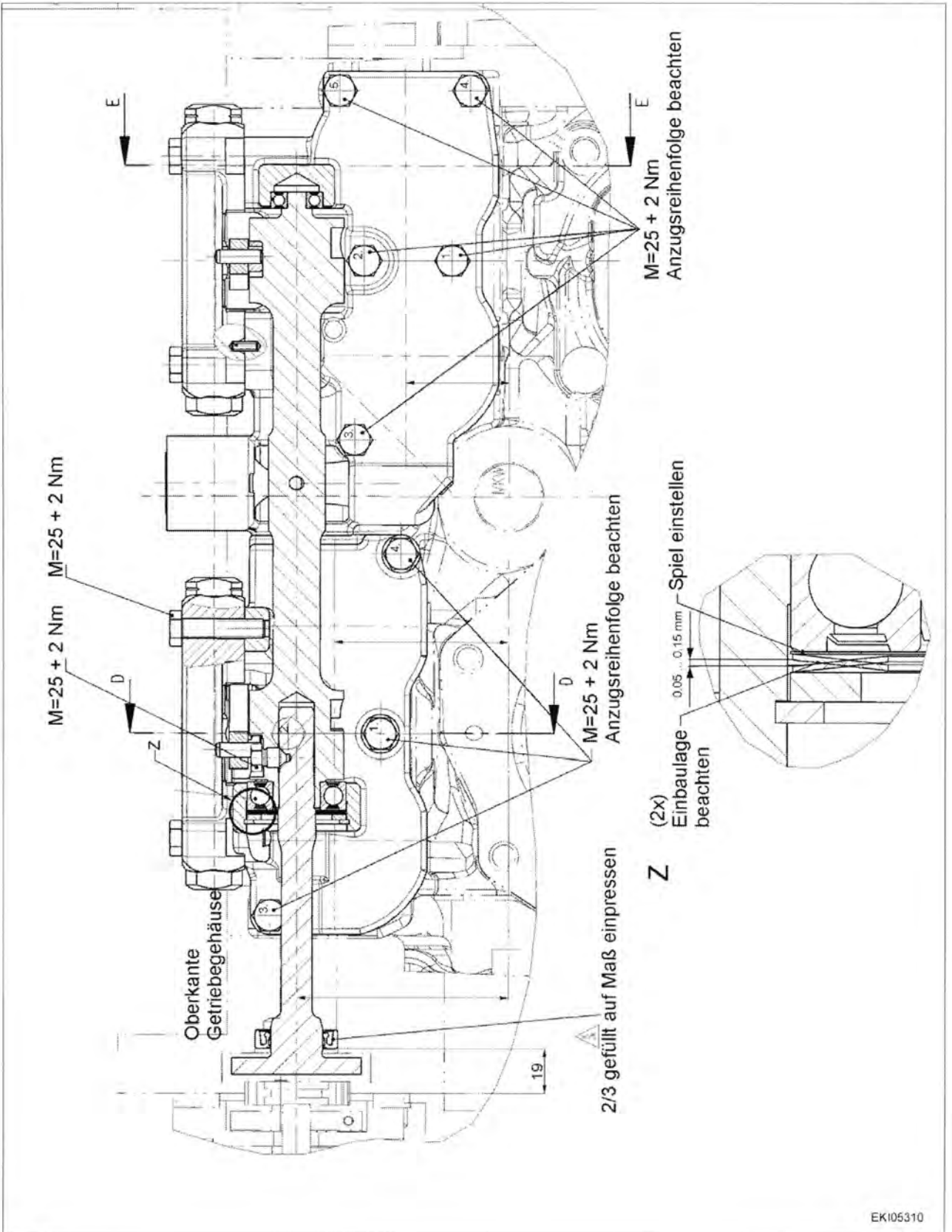
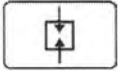

Fig. 74.

EK105310

1007374



Connect carrier coupling with the two increases (arrow) pointing towards the actuator unit

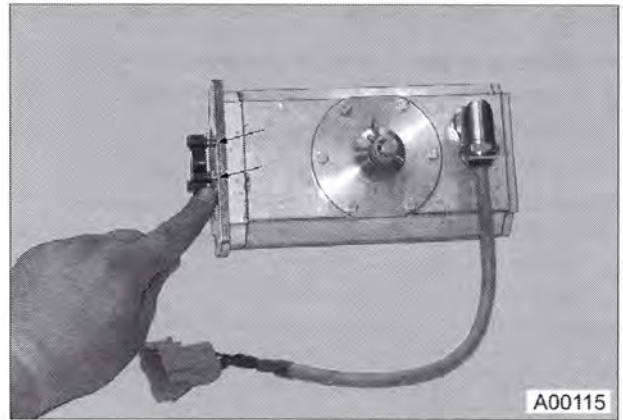
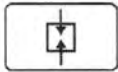

Fig. 75.

I000711



Fit pre-mounted actuator unit to the transmission housing

Tighten the M8 socket head cap screws to 25 Nm

Connect electrical cables

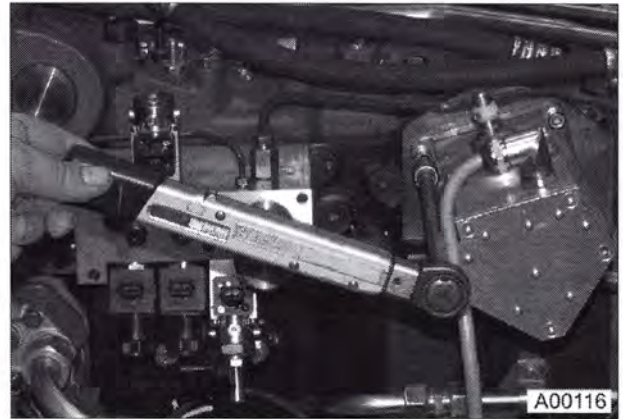

Fig. 76.

I000712

4 Replacing high-pressure limiting valve

Preliminary work: Drain off transmission oil (approx. 87 l), unscrew the two screw plugs on the underside of the transmission.

Dismantle 2V3 or 2V4 using socket spanner (SW 27)

NOTE: 2V3 = high-pressure limiting valve, forwards
2V4 = high-pressure limiting valve, reverse

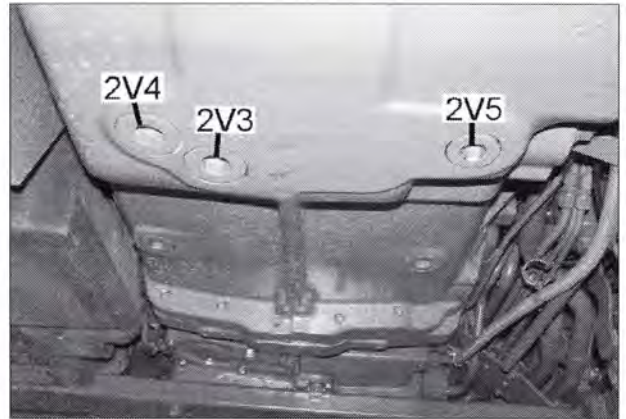

Fig. 77.

1002226

The high-pressure limiting valves are servo-assisted pressure limiting valves.

New pressure setting: 540 bar

Used pressure setting: 520 ± 20 bar

Only replace O-rings if they are damaged, take care with the positioning of the support rings

Tighten the 2V3 and 2V4 to 250 + 20 Nm, tighten the plug screws to 100 Nm

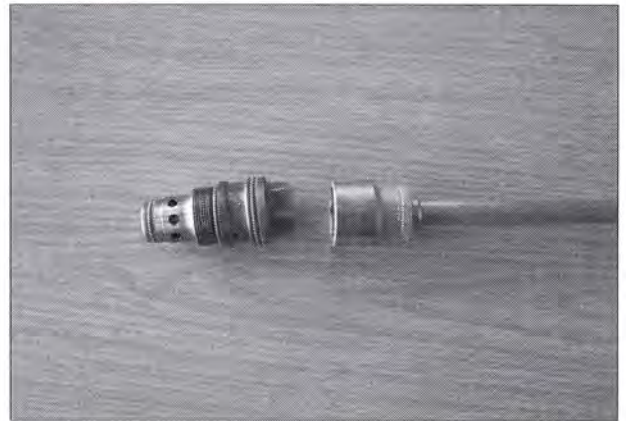

Fig. 78.

1002228

IMPORTANT: If a high-pressure limiting valve (2V3 or 2V4) was dismantled for inspection, the transmission must be topped up using the external filling station!

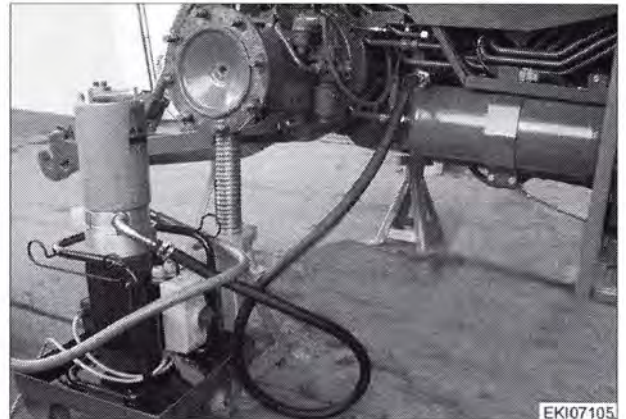

Fig. 79.

EKI07105

1002250

5 Replacing the purge valve

Preparatory work: Drain off transmission oil (approx. 87 l), unscrew the screw plugs on the underside of the transmission.

Dismantle the **2V5 = purge valve** using a socket wrench (SW 22)

Only replace the O-rings if they are damaged. Check the position of the support rings. The support rings face towards each other.

Tighten the 2V5 = purge valve to 250 + 20 Nm, tighten the screw plugs to 100 Nm

IMPORTANT: If the purge valve (2V5) was dismantled for inspection, the transmission must be topped up using the external filling station!

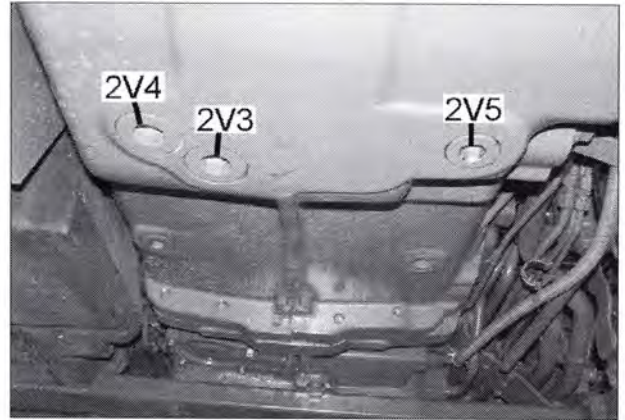

Fig. 80.

1002226

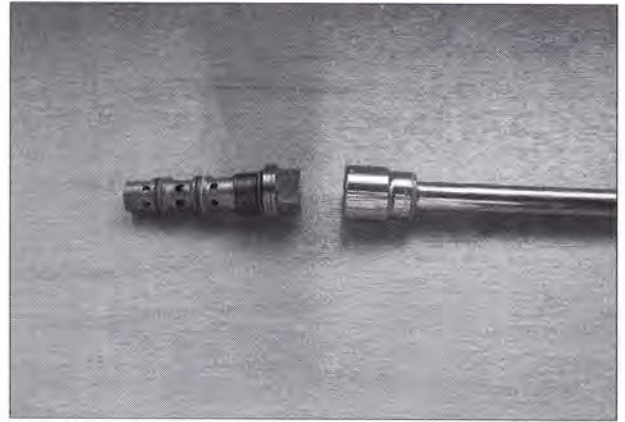

Fig. 81.

1002227

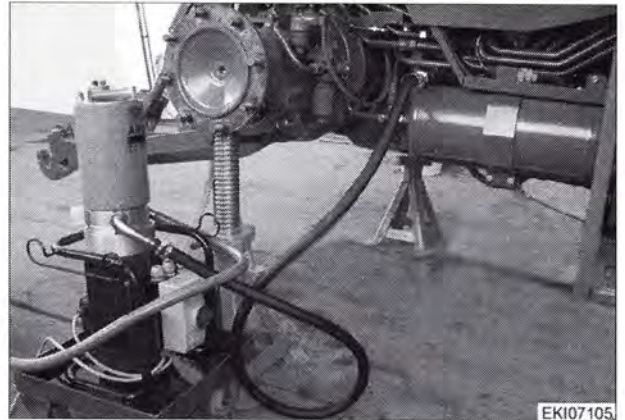

Fig. 82.

EK107105

1002250

6 Top up the transmission oil

During normal maintenance work, e.g. transmission oil change and/or filter change, top up transmission oil at rear left.

Observe instructions for oil type and quantity.

First filling approx. 87 l

Refilling approx. 67 l

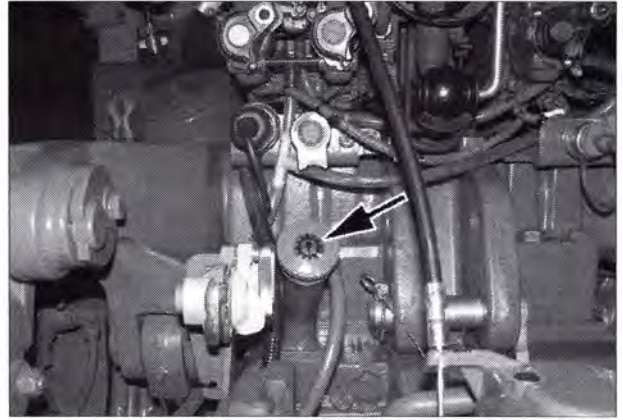

Fig. 83.

1002902

Topping up the oil is always necessary when:

1. Replacing the transmission unit (ML transmission)
2. When high-pressure unit is empty, e.g. after removal of high-pressure valves or the discharge valve (purge valve)

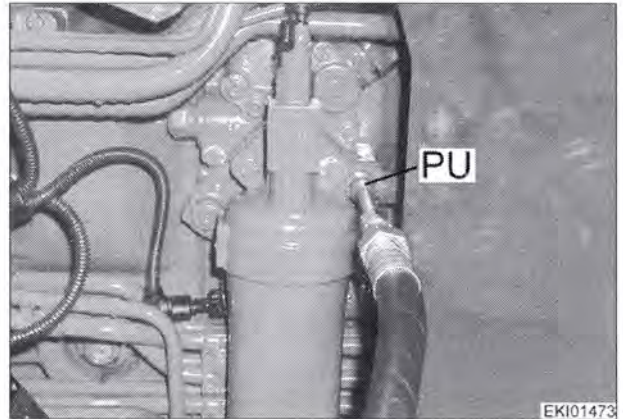

Fig. 84.

EKI01473

1002904

- 1 Suction hose from oil reservoir
- 2 Vacuum gauge
- 3 Pump
- 4 230 V AC electric motor drive
- 5 Microfilter with filter monitor
- 6 Pressure hose to tractor
- 7 Pressure hose to the oil cleaner of the service hydraulics (does not operate when external oil filler function is in use)

NOTE: Using the external oil filler unit prevents the hydraulic pump and hydraulic motors from running dry

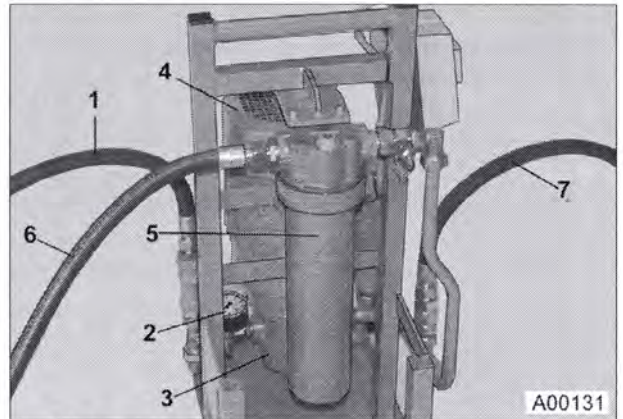

Fig. 85. External oil filler unit with microfilter

A00131

1002909