

FENDT

Werkstatthandbuch

Workshopmanual

Manuel d'atelier

Manual de taller

Manuale per l'officina

Werkplaatshandboek

FENDT 900 Vario COM III

X 990.005.057.012

1

FENDT

A	General
B	Faults
C	Documents and Diagrams
D	Component location
E	Testing
F	Setting and Calibration
G	Repair
H	Service – Info

1220

Transmission / Live PTO

FENDT 900 Vario - COM III

Volume 1

0000	Overall system/tractor
1005	Overall system/transmission
1010	Transmission/differential
1015	Transmission/axle drive
1050	Transmission/housing
1070	Transmission / Brake system
1080	Transmission/drive train
1200	Transmission/front PTO
1220	Transmission / Live PTO
1320	Transmission/front wheel drive
2000	Overall system/engine
2010	Engine/cylinder head
2050	Engine/cooling
2060	Engine/fuel system
2210	Engine/crankcase
2312	Engine/lubrication
2400	Engine/exhaust system
2712	Engine/injectors
3000	Overall system/front axle
3120	Front axle/steering cylinder
3180	Front axle/cardan shaft

Volume 2

4000	Overall system/steering
4090	Steering system / hydraulic steering unit
5030	Vehicle layout/operator's seat
5500	Overall system/air conditioning system
8100	Overall system/cab
8610	Power lift/EPC electro-hydraulic control
8631	Power lift/hydraulic lift
8800	Overall system/compressed air system

Volume 3

9000	Overall system/electrical system
9015	Electrical system/starter lockout

FENDT 900 Vario - COM III

Volume 4

- 9410 Hydraulic pump installation/LS pump
- 9430 Hydraulic pump installation/steering pump
- 9534 Hydraulic piping/"Rüfa"reverse operation
- 9600 Overall system/hydraulic equipment
- 9605 Hydraulic equipment/hydraulic connections
- 9610 Hydraulic equipment/central control block (ZSB)
- 9620 Hydraulic equipment/valve fitting
- 9700 Overall system/electronics
- 9920 Service/special tools
- 9975 Service/SERDIA - Deutz engine diagnostics program

1220 Transmission / Live PTO

C	Documents and diagrams5
G	Repair9

C Documents and diagrams

1	Technical drawing of live PTO	7
---	-------------------------------------	---

1 Technical drawing of live PTO

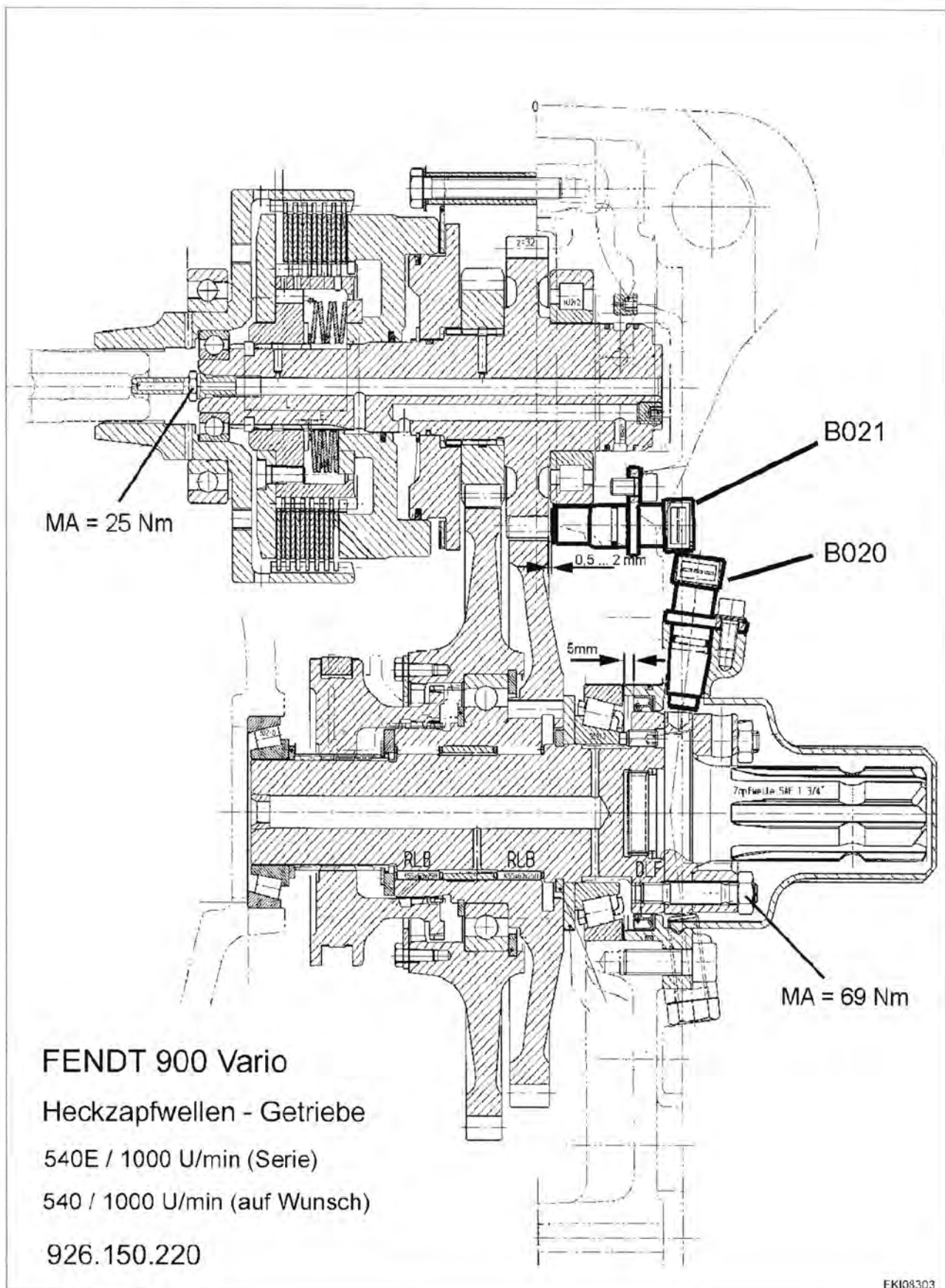

EKI08303

Fig. 1.

1001469

919 .. 0101-1000
 919 .. 1001-
 922 .. 0101-1000
 922 .. 1001-
 925 .. 0101-1000

925 .. 1001-
 928 .. 0101-1000
 928 .. 1001-
 931 .. 0101-1000
 931 .. 1001-

934 .. 0101-1000
 934 .. 1001-

T002636
 Version 1
 21-04-2009

G Repair

- 1 Assembling and removing live PTO clutch. 11
- 2 Assembling and dismantling live PTO clutch and gears. 22

1 Assembling and removing live PTO clutch

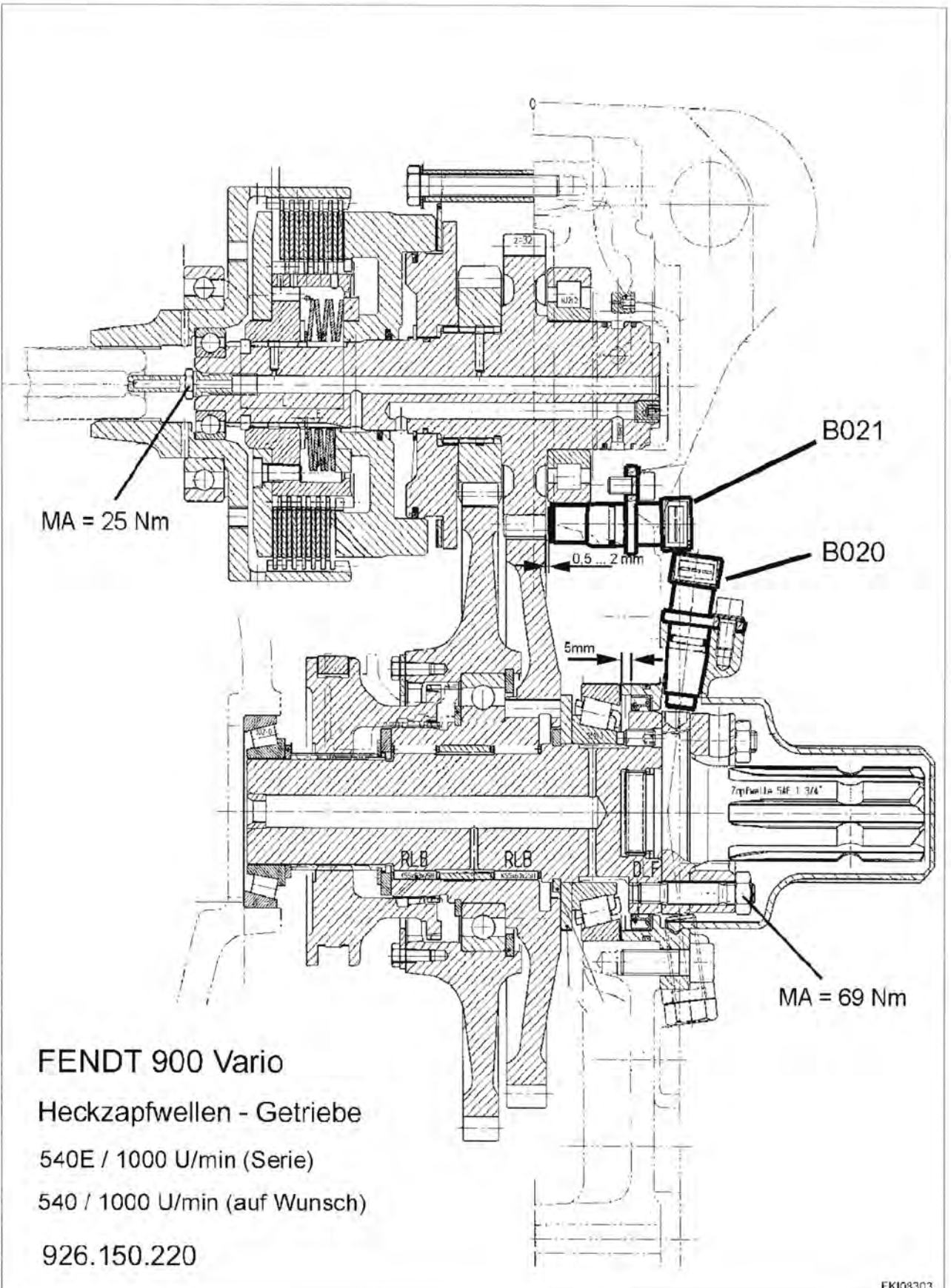

FENDT 900 Vario
 Heckzapfwellen - Getriebe
 540E / 1000 U/min (Serie)
 540 / 1000 U/min (auf Wunsch)
 926.150.220

EKI08303

Fig. 1.

1001469

919 .. 0101-1000	925 .. 1001-	934 .. 0101-1000
919 .. 1001-	928 .. 0101-1000	934 .. 1001-
922 .. 0101-1000	928 .. 1001-	
922 .. 1001-	931 .. 0101-1000	
925 .. 0101-1000	931 .. 1001-	

T001259
 Version 1
 07-11-2007

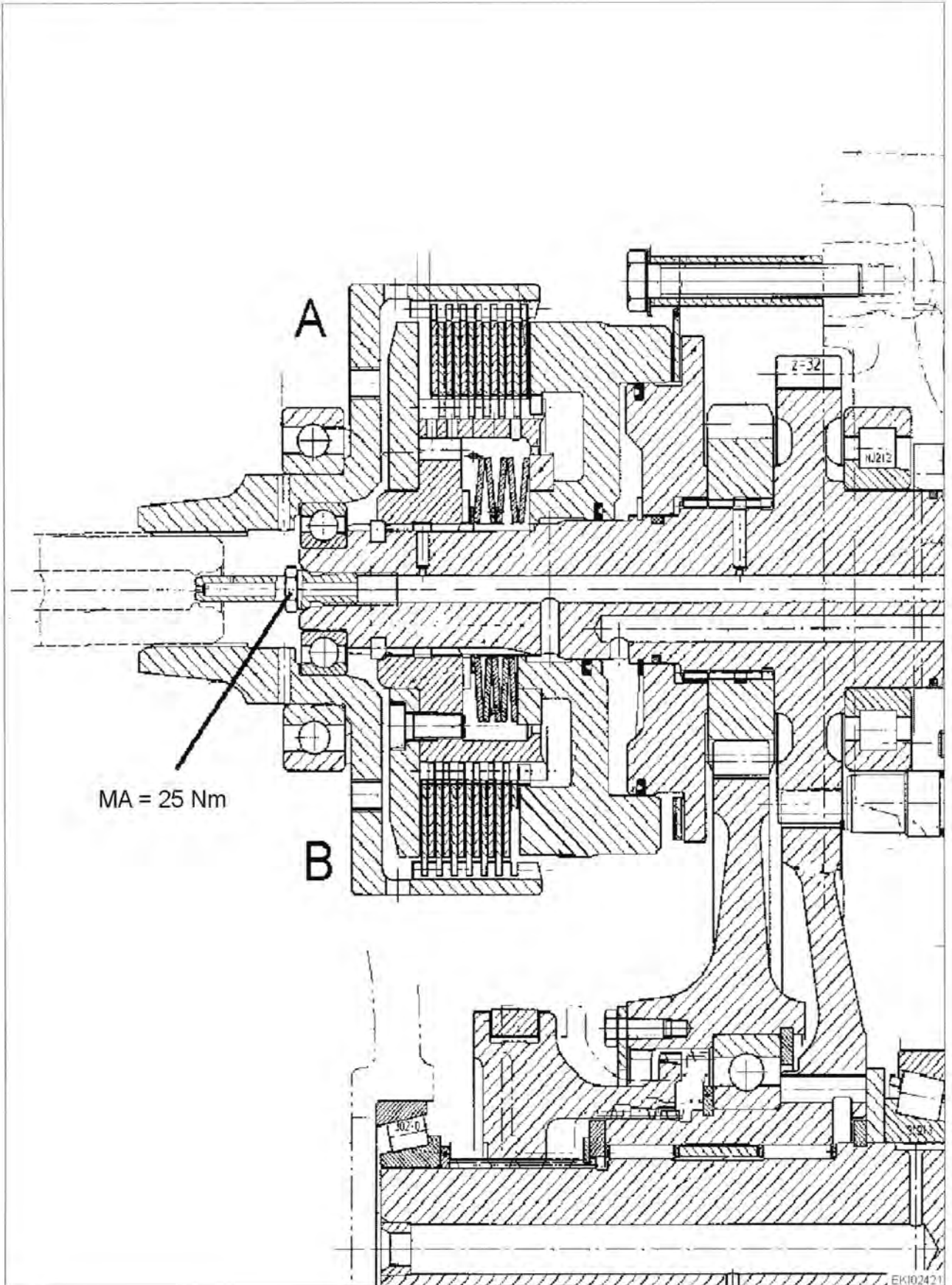
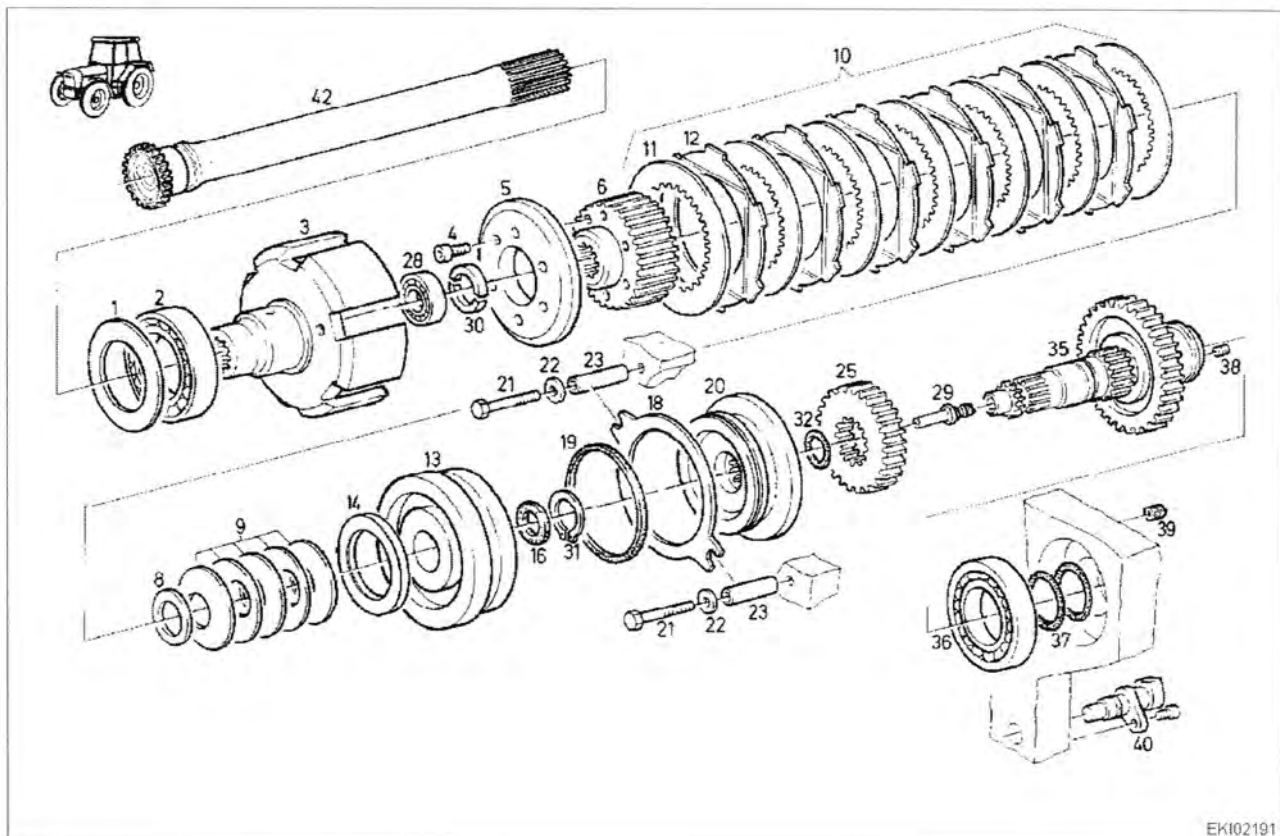

Fig. 2.

EKI02421
1003639



EK102191

1003640

Fig. 3.

Item	Designation	Item	Designation
1	Shim	21	Hex screw
2	Deep-groove ball bearing	22	Spring washer
3	Bell housing	23	Bush
4	Socket head cap screw	25	Spur gear
5	Locating ring	28	Deep-groove ball bearing
6	Internally toothed disc carrier	29	Nozzle
8	Shim	30	Half-ring
9	Belleville spring	31	Circlip
10	Disc package (11, 12)	32	O-ring
11	Externally toothed disc	35	Shaft
12	Internal disc	36	Cylinder roller bearing
13	Piston	37	Rectangular-section ring
14	Ring	38	Setscrew
16	Lip seal	39	Nozzle
18	Disc	40	B021 rear PTO clutch speed sensor
19	Lip seal	42	Shaft
20	Brake disc		

919 .. 0101-1000
 919 .. 1001-
 922 .. 0101-1000
 922 .. 1001-
 925 .. 0101-1000

925 .. 1001-
 928 .. 0101-1000
 928 .. 1001-
 931 .. 0101-1000
 931 .. 1001-

934 .. 0101-1000
 934 .. 1001-

T001259
 Version 1
 07-11-2007

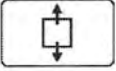

Preliminary work:

- Lower the rear power lift
- Drain transmission oil (approx. 67 l)
- Remove the trailer hitch
- Mark and unplug the X169 separation point at the B020 rear PTO stub shaft sensor
- Mark and unplug the X170 separation point at the B021 rear PTO clutch speed sensor
- Unscrew the compressed air couplings

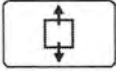

Unscrew all fixing bolts and nuts.
Remove the plugs from the threaded bores and screw in two jack screws M12 (arrows).
Secure the housing cover in the hoist and release the housing cover.



WARNING: Do not walk or stand under suspended loads!

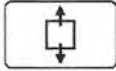

Remove the housing cover (with rear PTO).

NOTE: Take note of the shim (1).
The washer (1) is used to adjust the bearing play

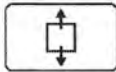

Dismantling the PTO clutch

Press in the clutch bell housing (3) with the help of two hex screws.

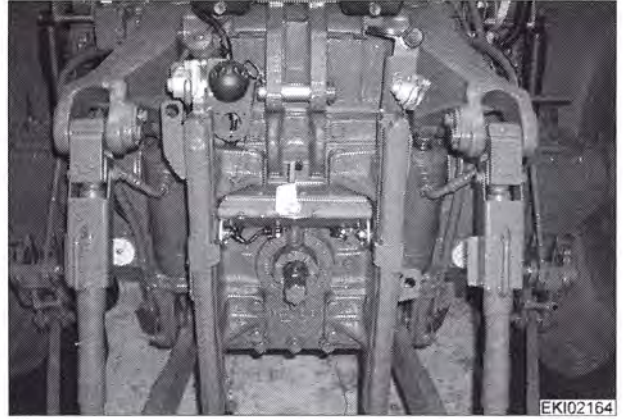

Fig. 4.

EKI02164
1003641

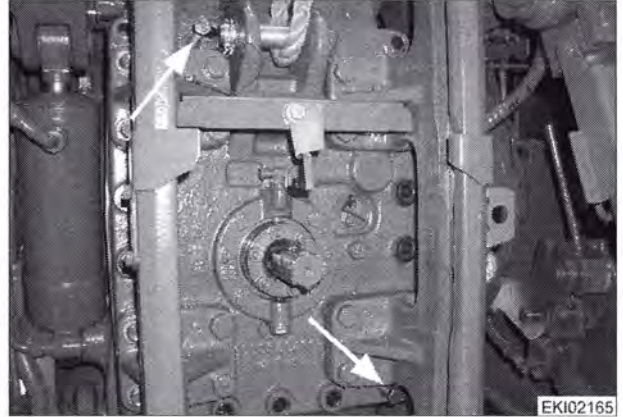

Fig. 5.

EKI02165
1003642

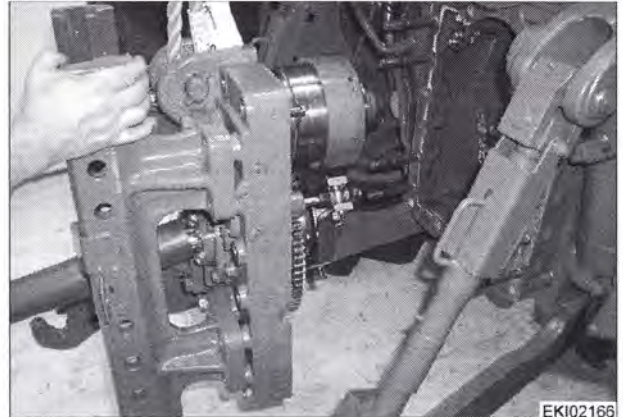

Fig. 6.

EKI02166
1003643

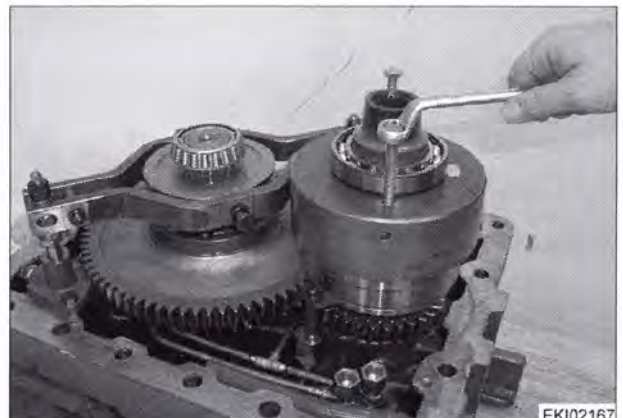
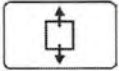

Fig. 7.

EKI02167
1003644



Remove the nozzle (29)

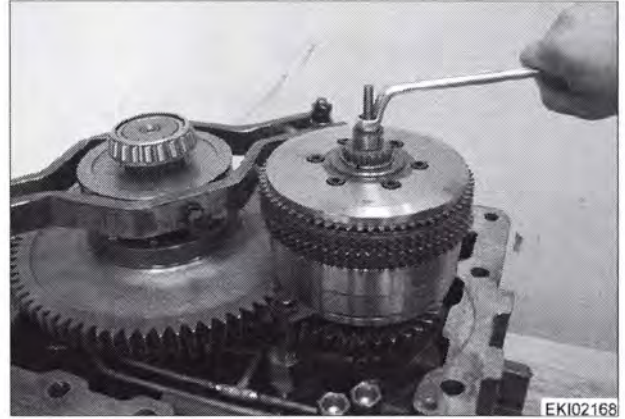
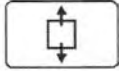

Fig. 8.

EKI02168
1003645



Set up the X899.980.145 jig.
Tighten the clutch.
Remove the half-rings (30)
Remove the internal toothed disc carrier (6) and disc package (10).

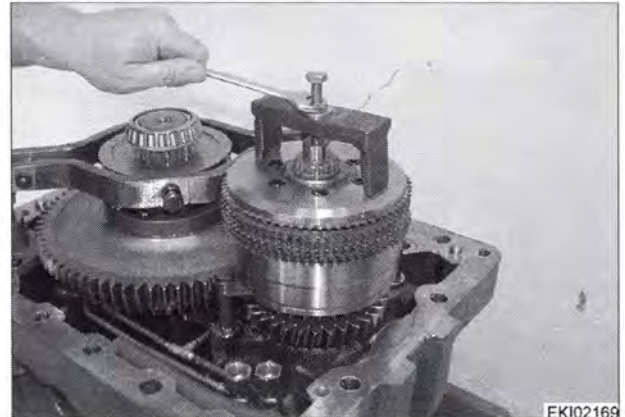
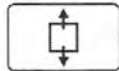

Fig. 9.

EKI02169
1003646



Remove the washers (8), belleville spring package (9) and ring (14)

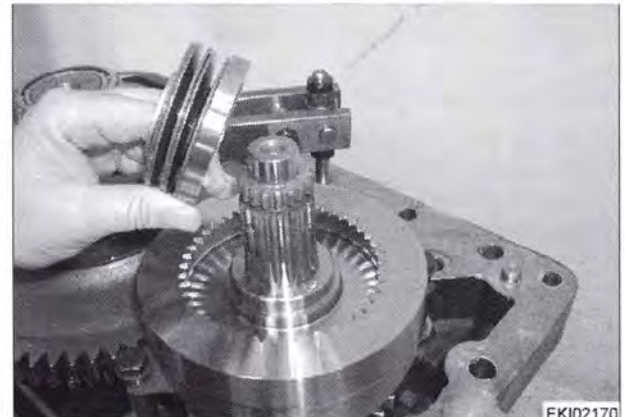
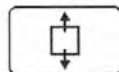

Fig. 10.

EKI02170
1003647



Remove the piston (13)

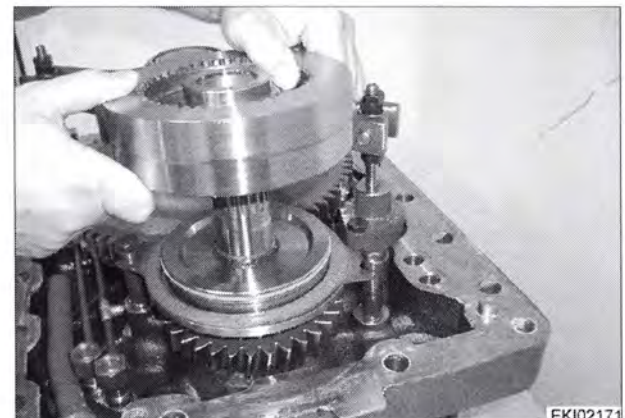
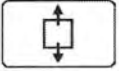

Fig. 11.

EKI02171
1003648

919 .. 0101-1000	925 .. 1001-	934 .. 0101-1000
919 .. 1001-	928 .. 0101-1000	934 .. 1001-
922 .. 0101-1000	928 .. 1001-	
922 .. 1001-	931 .. 0101-1000	
925 .. 0101-1000	931 .. 1001-	



Remove one hex screw (21) and dismantle the disc (18).

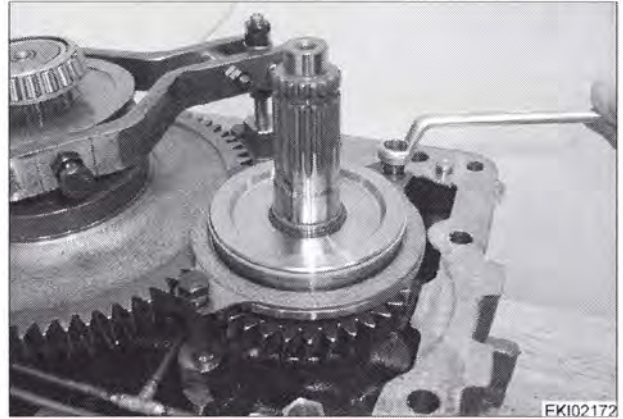
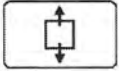

Fig. 12.

EKI02172
1003649

Snap out the circlip (31) and remove the brake disc (20).

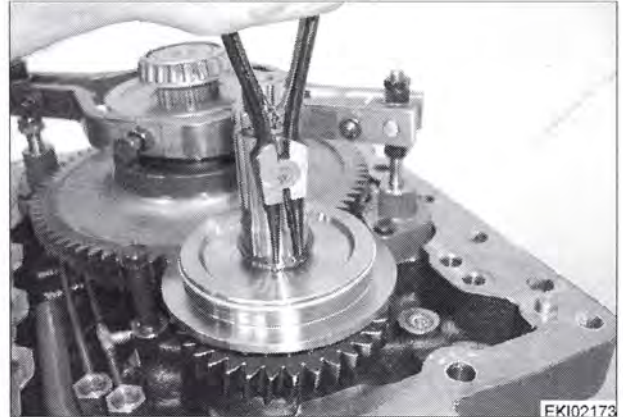
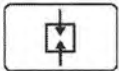

Fig. 13.

EKI02173
1003650

Assembling the PTO clutch

Place the new O-ring (32) in the groove of the shaft (35) and grease it.

Check the brake disc (20) for damage.
If necessary, fit a new brake disc (20).

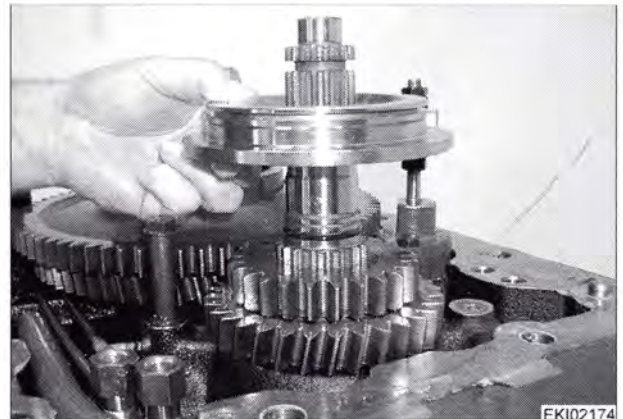
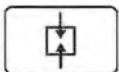

Fig. 14.

EKI02174
1003651

Put the circlip (31) in place.
Place the new lip seal (19) with the seal facing the oil chamber in the groove of the brake disc (20) and grease it.

NOTE: See also:
Technical drawing

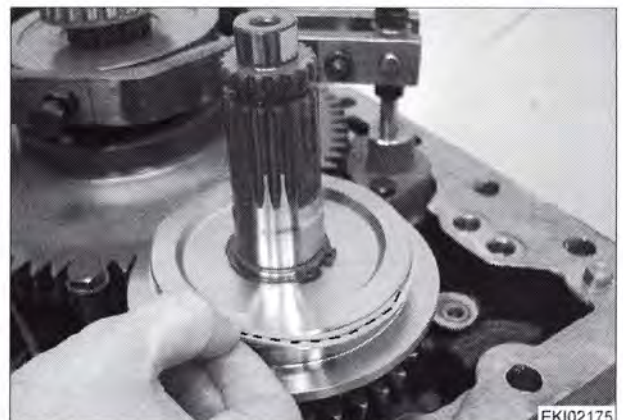
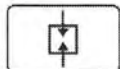

Fig. 15.

EKI02175
1003652



Put the disc (18) in place.
 Coat the threads of the hex screw (21) with X 903.054.084 synthetic bonding agent.
 Attach the spring washer (22) and bush (23).
 Tighten the hex screw

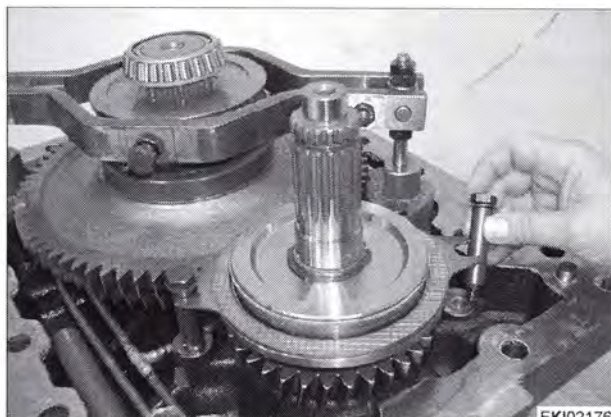
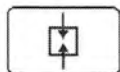

Fig. 16.

EKI02176
1003653



Place the new lip seal (16) with the seal facing the oil chamber in the inner groove of the piston (13) and grease it.

NOTE: See also:
 Technical drawing



Fig. 17.

EKI02177
1003654

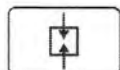

Mount the pre-assembled piston (13).
 Fit the ring (14).



Fig. 18.

EKI02178
1003655

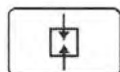

Mount the five belleville springs (9) so that their larger diameters face each other.
 Put the existing shim (8) in place.

NOTE: The first belleville spring (9) is placed so that its larger diameter faces the ring (14)

See also:
 Technical drawing

If necessary, (e.g. shim (8) is misplaced or the internal toothed disc carrier (6) is replaced): Determine the preload of the belleville springs (9)

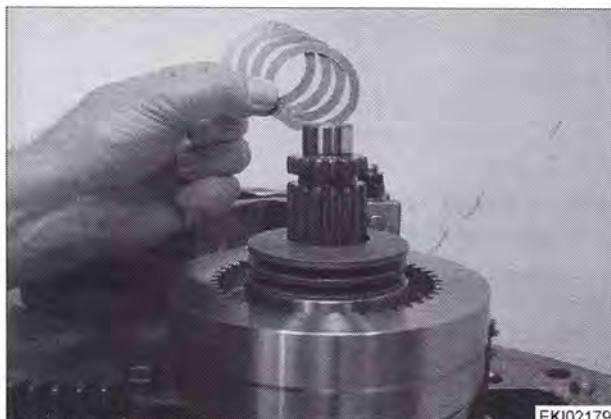
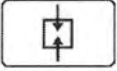

Fig. 19.

EKI02179
1003656



Determine the preload of the belleville springs (9)

If it has been removed: Mount the locating ring (5) on the internal toothed disc carrier (6).

Coat the threads of the socket head cap screw (4) with X 903.050.084 synthetic bonding agent.

Tighten the socket head cap screws (4).

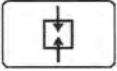

Fig. 20.

EKI02180
1003657

Fit the pre-assembled internal toothed disc carrier (6).

Measure and note the distance between the front side of the shaft (35) and the internal toothed disc carrier (6).

E.g. 23.2 mm

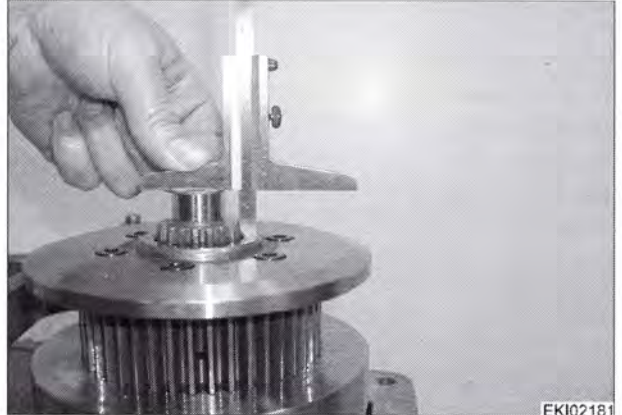
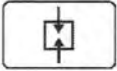

Fig. 21.

EKI02181
1003658

Set up the X 899.980.145 jig and tighten the belleville springs (9).

Fit the ring halves (30).

In the case of ring halves (30) bevelled on one side, the bevel faces the internal toothed disc carrier (6)

Dismantle the X899.980.145 jig.

NOTE: See also:
Technical drawing

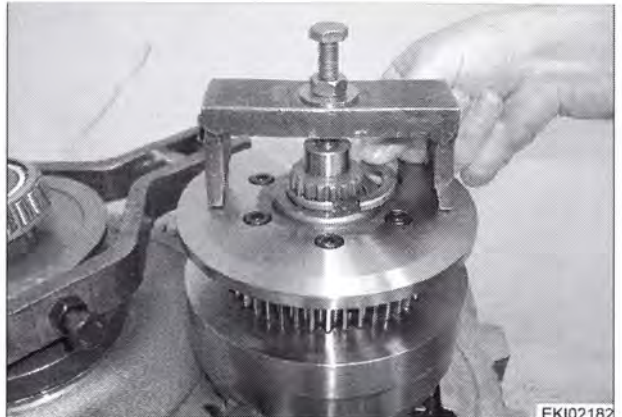
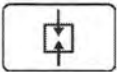

Fig. 22.

EKI02182
1003659

Measure and note the distance between the front side of the shaft (35) and the internal toothed disc carrier (6).

E.g. 25.8 mm

If the belleville package (9) is pressed together by approx. 2.5 mm it will have the correct preload.

In the event of deviations, correct it using shims (8).

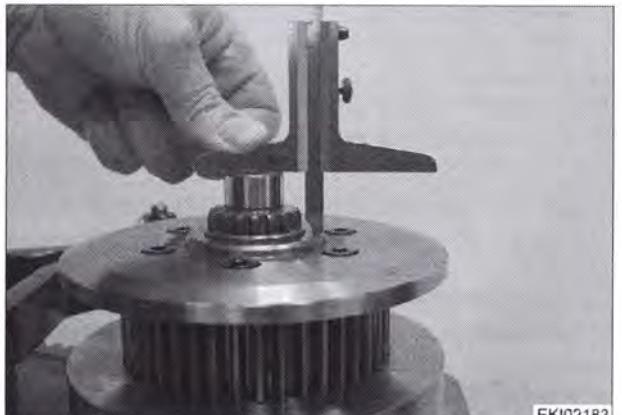
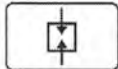

Fig. 23.

EKI02183
1003660



Thread the disc package (10) on the internally toothed disc carrier (6).

Starting with an externally toothed disc (11), continue alternately with an internally toothed disc (12). In the process, the narrow groove (item 2) in **each** internally toothed disc (12) and the broad groove (item 3) in **every other** internally toothed disc (12) must be aligned.

Number of discs:

9 items of externally toothed disc (11)

8 items of internally toothed disc (12)

Rear axle HA 200

Number of discs

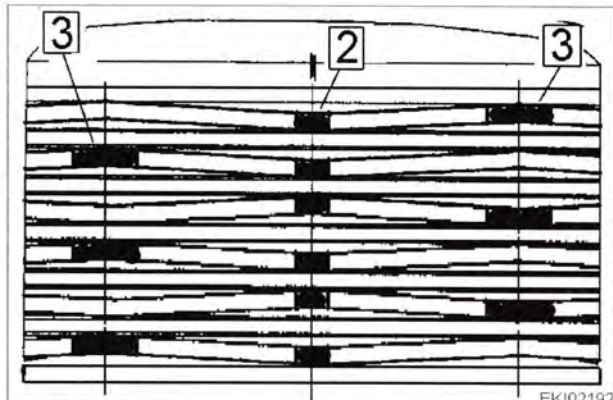
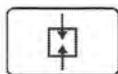

Fig. 24.

EKI02192
1003661



Put the disc package (10) on the internally toothed disc carrier (6).



Fig. 25.

EKI02184
1003662

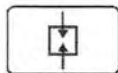

Set up the X899.980.145 jig.
Tighten the clutch.
Fit the ring halves (30).
In the case of ring halves (30) bevelled on one side, the bevel faces the internal toothed disc carrier (6)

NOTE: See also:
Technical drawing

NOTE: If the internally toothed disc carrier (6) does not latch, place the internally toothed disc carrier (6) without the disc package (10) and mark the teeth with a coloured pen.

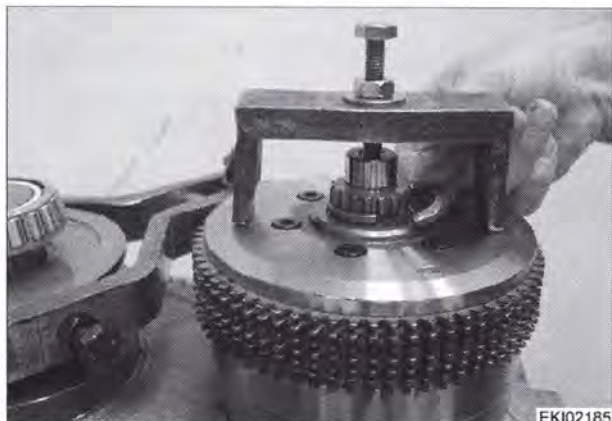
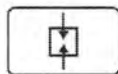

Fig. 26.

EKI02185
1003668



Measure the air gap with a feeler gauge

Press in the disc package centrally.
Measure the air gap with a feeler gauge.

Target value: 1.60 mm ... 2.9 mm (air gap).

If the minimum air gap of 1.60 mm cannot be attained, the discs are screened.

Fit a new disc package (10)

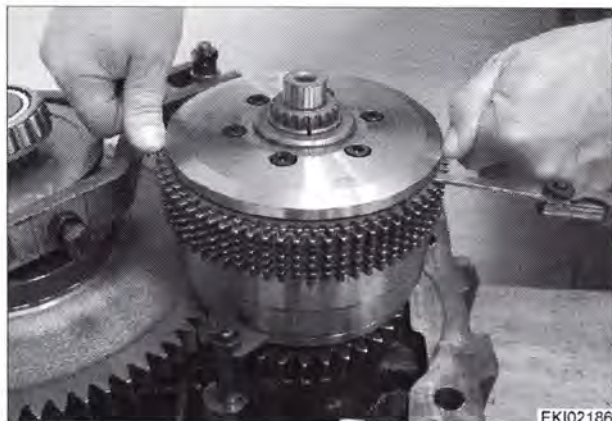

Fig. 27.

EKI02186
1003669

919 .. 0101-1000
919 .. 1001-
922 .. 0101-1000
922 .. 1001-
925 .. 0101-1000

925 .. 1001-
928 .. 0101-1000
928 .. 1001-
931 .. 0101-1000
931 .. 1001-

934 .. 0101-1000
934 .. 1001-

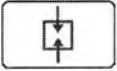

Coat the thread of the nozzle (29) with X 903.050.084 synthetic bonding agent.
Tighten the nozzle (29) with a torque of **25 Nm** .

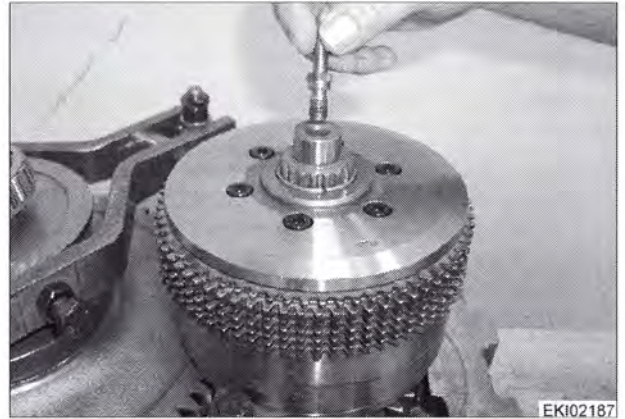
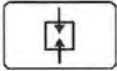

Fig. 28.

EKI02187
1003670



If it has been removed:
Press the deep-groove ball bearing (28) with the closed side facing the top into the clutch bell housing (3) until it fits in place.



Fig. 29.

EKI02194
1003671

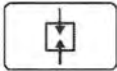

If it has been removed:
Press on the deep-groove ball bearing (2) until it fits on the bell housing (3).



Fig. 30.

EKI02193
1003672

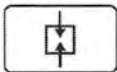

Align the externally toothed discs (11) and press on the bell housing (3) until they fit in place

NOTE: Do not bend the discs (11, 12) !

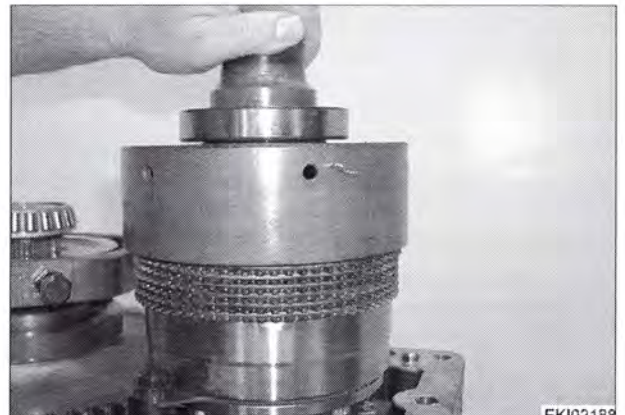
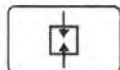

Fig. 31.

EKI02188
1003673



Clean the flange surfaces.
 Ensure that the two locating pins (arrowed) are fitted.
 Coat flange surface with X 903.050.074 surface sealant.

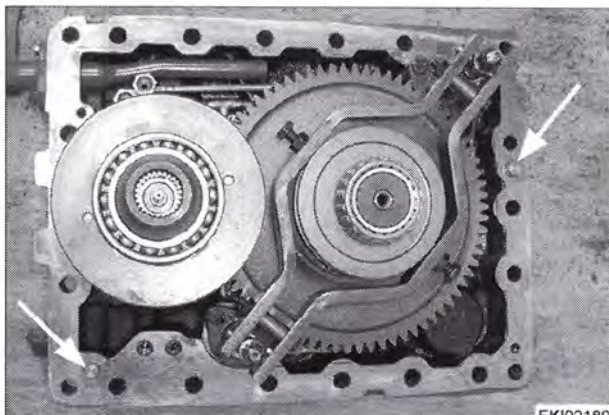
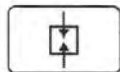

Fig. 32. EKI02189
1003675



Place the existing shims (1) in the upper bore.

NOTE: Determining the shim (1)
 see §2

Fit and grease four new O-rings for the pressure connections (arrow).

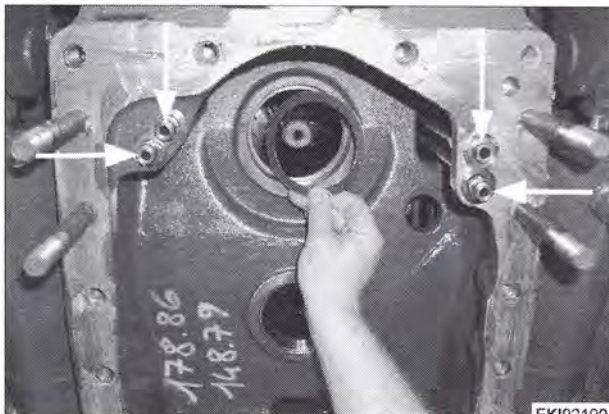
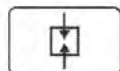

Fig. 33. EKI02190
1003676



Secure the housing cover in the hoist and fit the rear axle housing.

WARNING: Do not walk or stand under suspended loads!

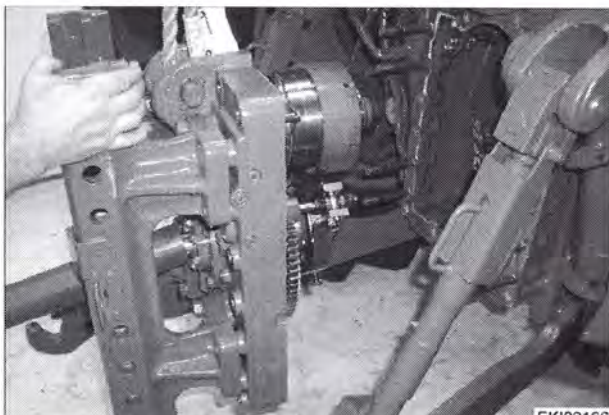
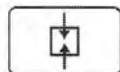

Fig. 34. EKI02166
1003643



- Tighten the fixing bolts and nuts M18 with **400 Nm**.
- Plug in the X169 separation point at the B020 rear PTO stub shaft sensor
- Plug in the X170 separation point at the B021 rear PTO clutch speed sensor
- Attach the compressed air couplings
- Attach the trailer hitch
- Replenish transmission oil

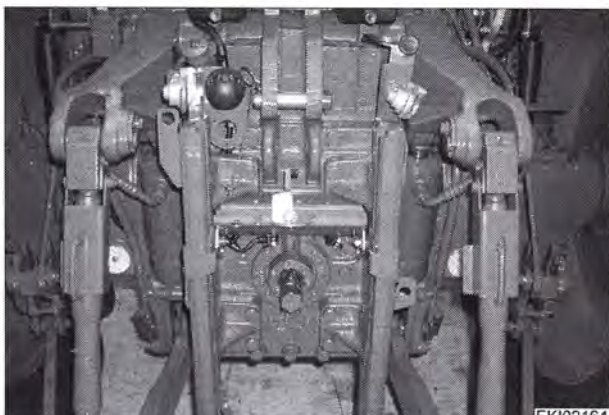
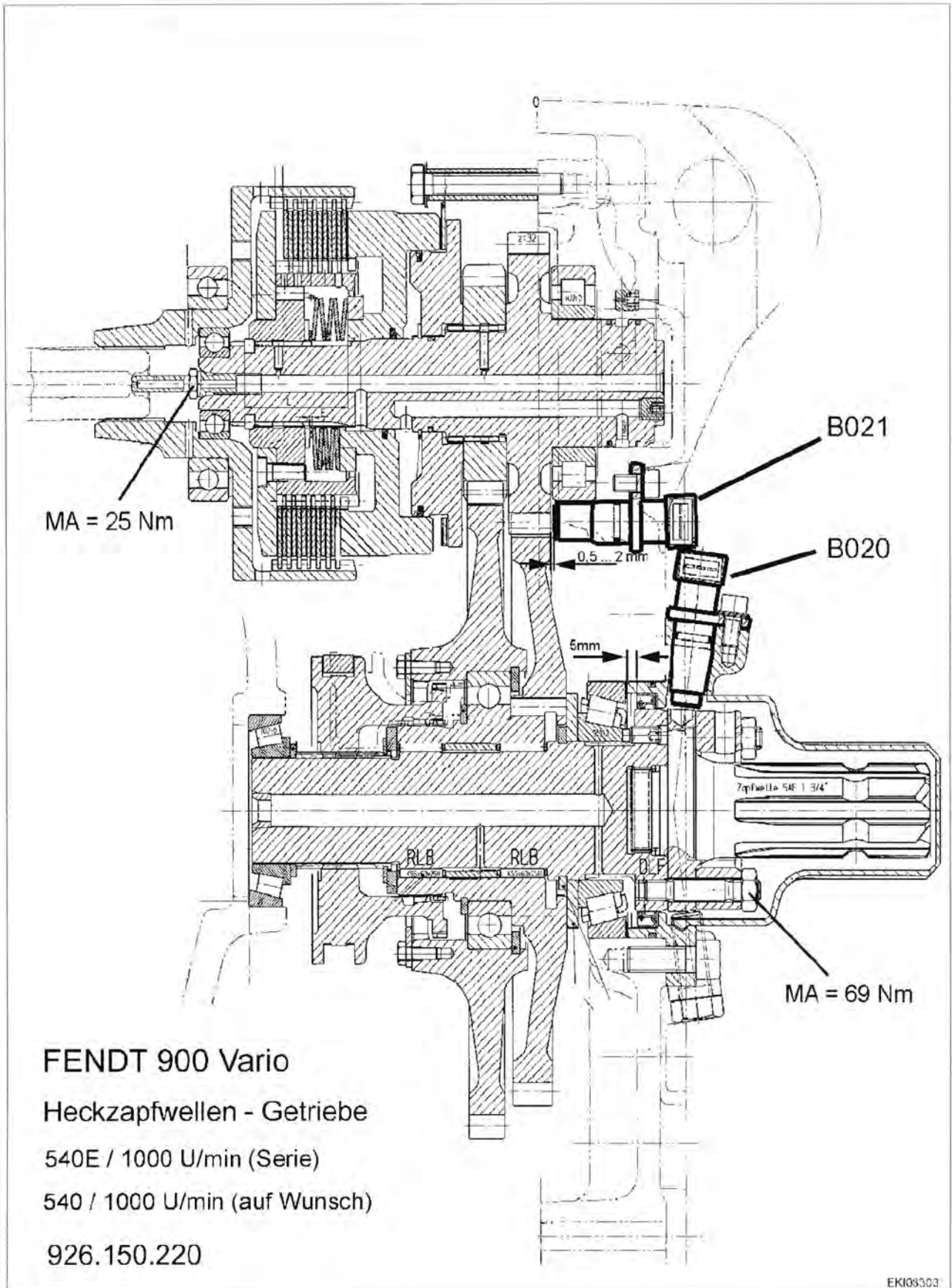

Fig. 35. EKI02164
1003641

2 Assembling and dismantling live PTO clutch and gears

PTO transmission



EKI03303

Fig. 36.

1001469

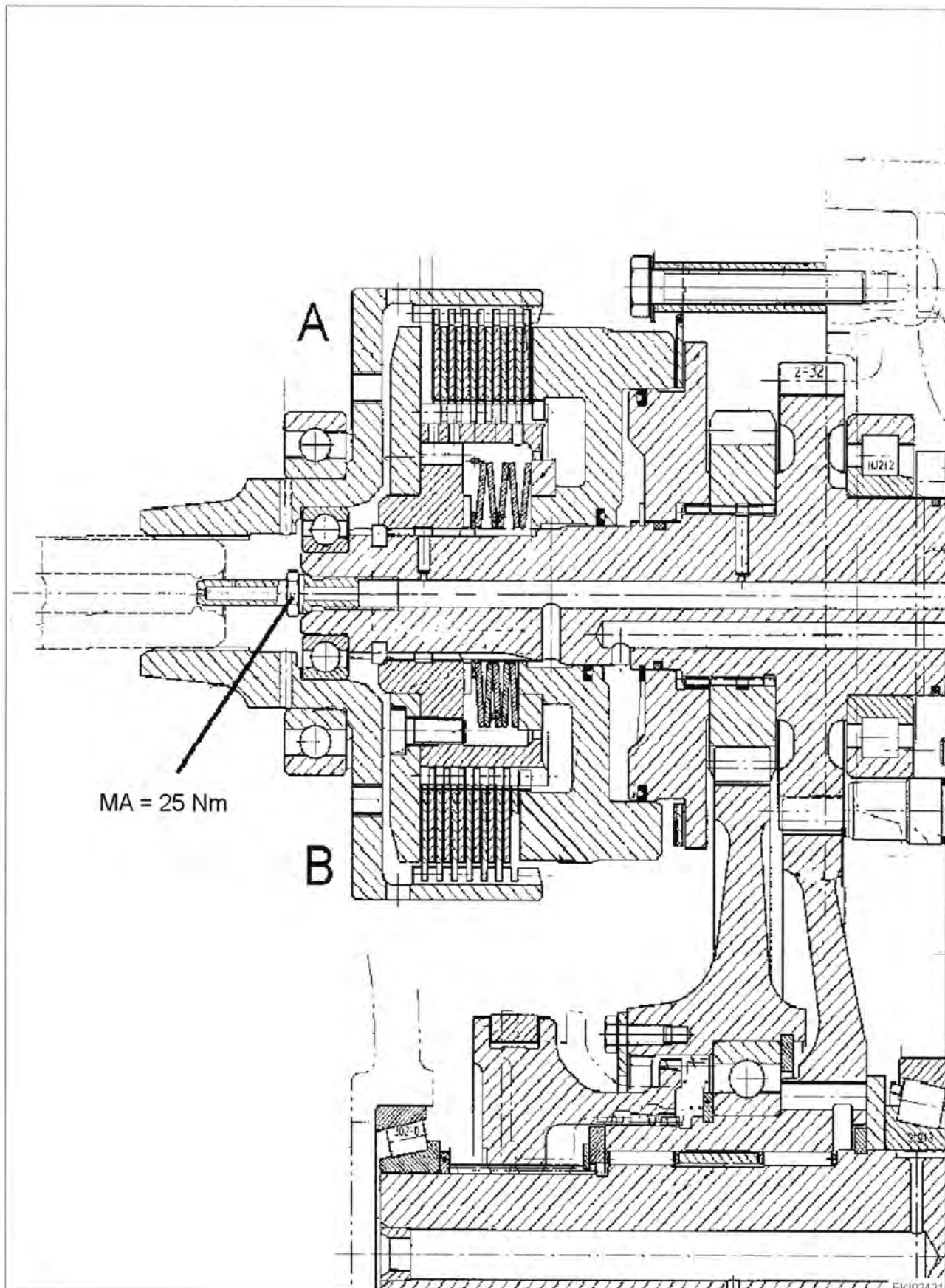

Fig. 37.

EK102421
1003639

919 .. 0101-1000
919 .. 1001-
922 .. 0101-1000
922 .. 1001-
925 .. 0101-1000

925 .. 1001-
928 .. 0101-1000
928 .. 1001-
931 .. 0101-1000
931 .. 1001-

934 .. 0101-1000
934 .. 1001-

T001262
Version 1
07-11-2007

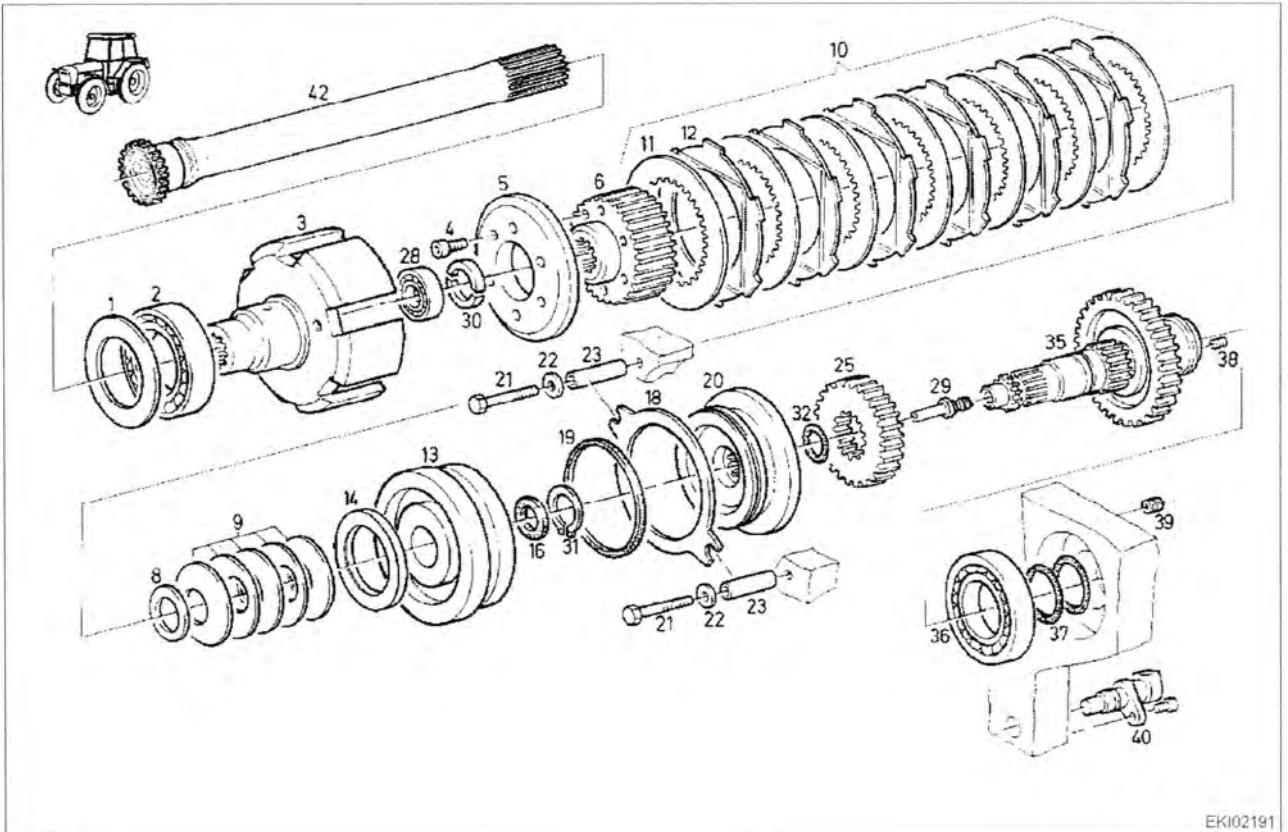

EKI02191

Fig. 38.

1003640

Item	Designation	Item	Designation
1	Shim	21	Hex screw
2	Deep-groove ball bearing	22	Spring washer
3	Bell housing	23	Bush
4	Socket head cap screw	25	Spur gear
5	Locating ring	28	Deep-groove ball bearing
6	Internally toothed disc carrier	29	Nozzle
8	Shim	30	Half-ring
9	Belleville spring	31	Circlip
10	Disc package (11, 12)	32	O-ring
11	Externally toothed disc	35	Shaft
12	Internally toothed disc	36	Cylinder roller bearing
13	Piston	37	Rectangular-section ring
14	Ring	38	Setscrew
16	Lip seal	39	Nozzle
18	Disc	40	B021 rear PTO clutch speed sensor
19	Lip seal	42	Shaft
20	Brake disc		

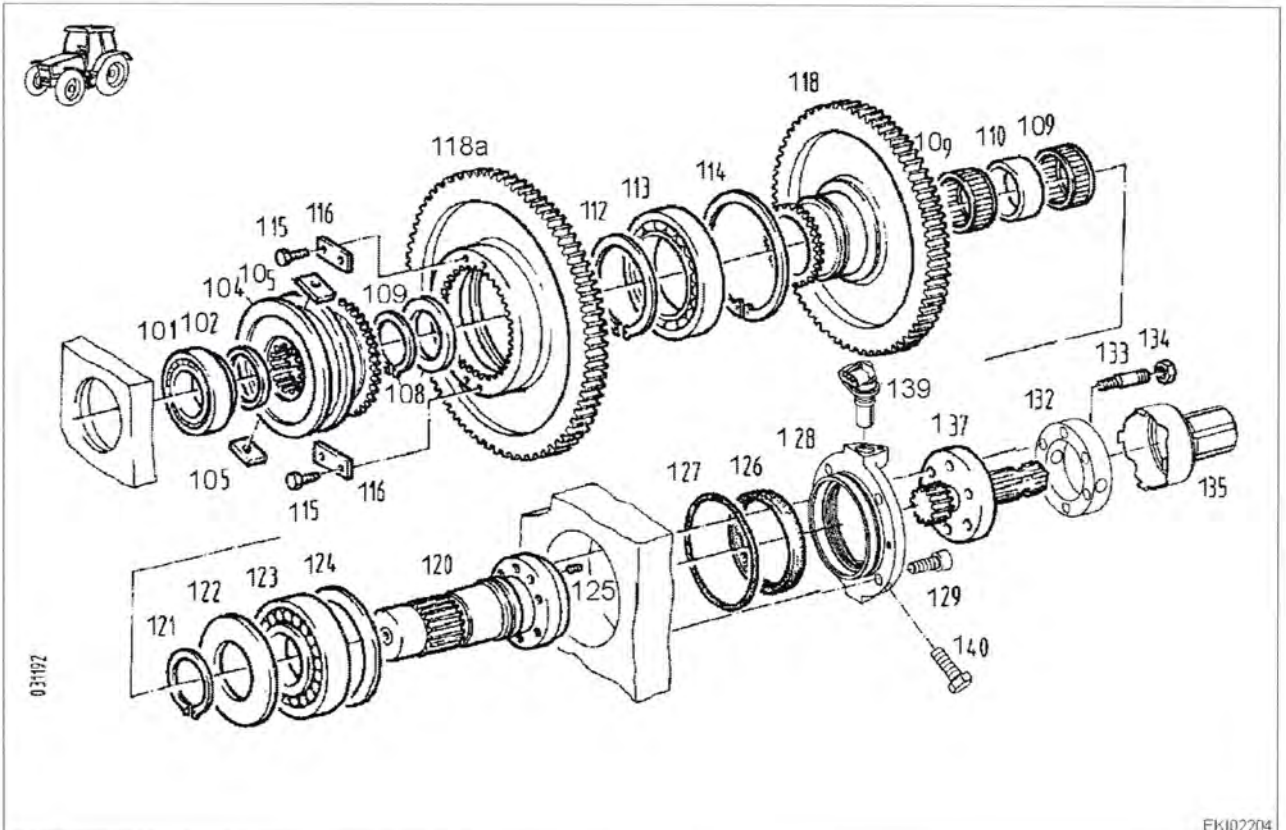

Fig. 39.

EK102204

1003681

Item	Designation	Item	Designation
101	Taper roller bearing	121	Circlip
102	Locating ring	122	Washer
104	Clutch body	123	Taper roller bearing
105	Slider	124	Shim
107	Circlip	125	Setscrew
108	Washer	126	Shaft seal ring
109	Needle bearing	127	O-ring
110	Spacer	128	Bearing cover
112	Circlip	129	Socket head cap screw
113	Deep-groove ball bearing	132	Spacer
114	Circlip	133	Stud bolt M10 x 50 - 10.9
115	Hex screw	134	Hex nut M10-10
116	Stop	135	PTO shaft guard
118	Spur gear (1000 rpm)	137	Flange pivot
118a	Spur gear (540 or 750 rpm)	139	B020 rear PTO stub shaft sensor
120	Shaft	140	Hex nut

919 .. 0101-1000
 919 .. 1001-
 922 .. 0101-1000
 922 .. 1001-
 925 .. 0101-1000

925 .. 1001-
 928 .. 0101-1000
 928 .. 1001-
 931 .. 0101-1000
 931 .. 1001-

934 .. 0101-1000
 934 .. 1001-

T001262
 Version 1
 07-11-2007

PTO gear shift

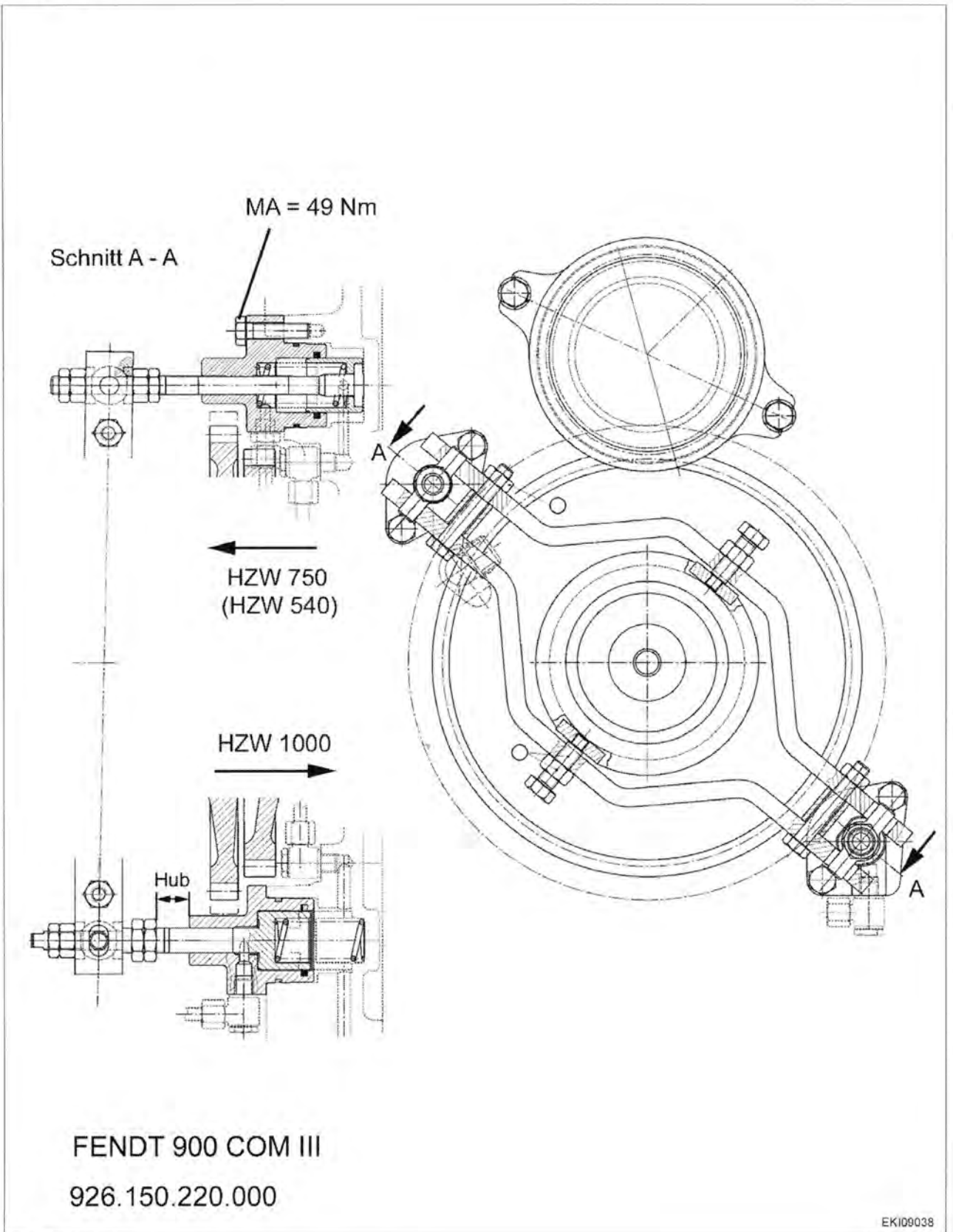

EKI09038

Fig. 40.

1003726

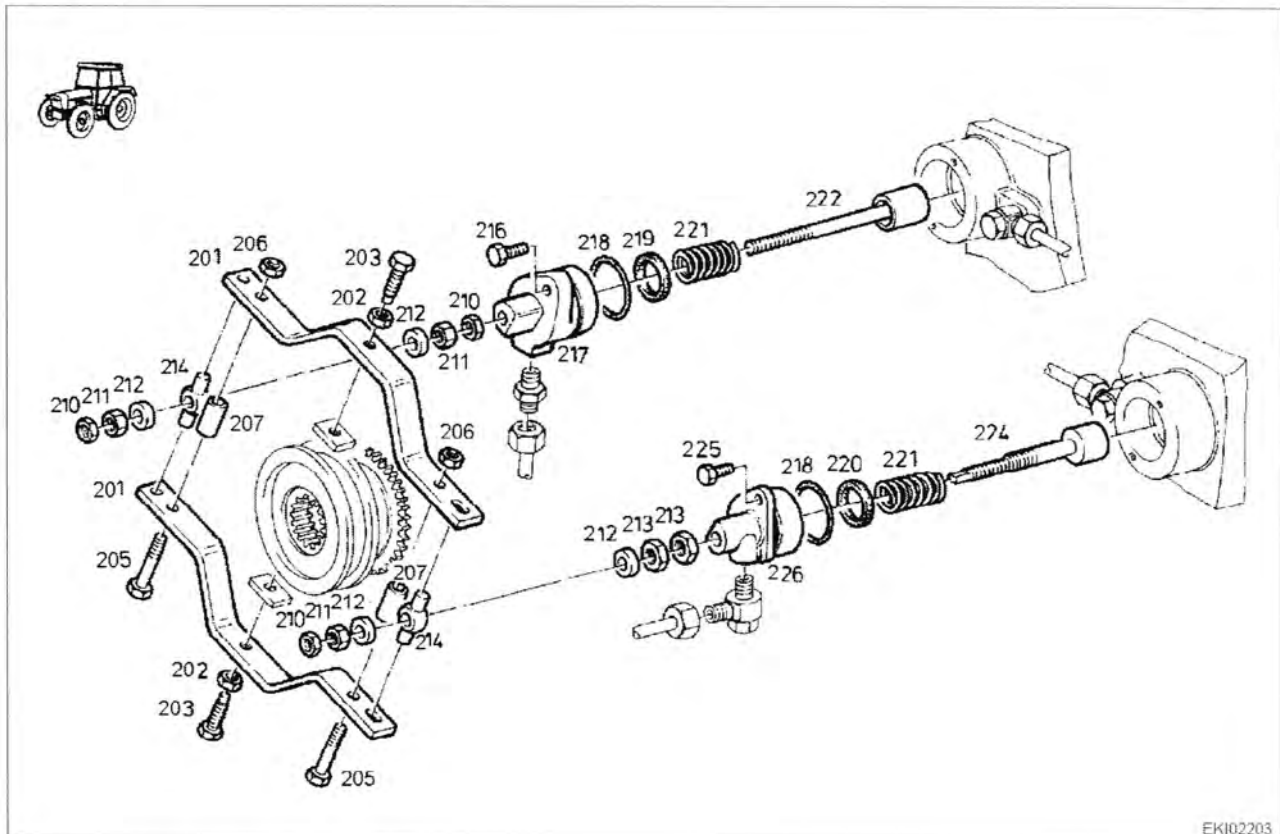

EKI02203

1003682

Fig. 41.

Item	Designation	Item	Designation
201	Strap	216	Hex screw
202	Hex nut	217	Cylinder
203	Stud bolt	218	O-ring
205	Hex screw	219	Compact seal ring
206	Hex nut	220	Compact seal ring
207	Spacer sleeve	221	Pressure spring
210	Hex nut	222	Piston
211	Hex nut	224	Piston
212	Washer	225	Hex screw
213	Hex nut	226	Cylinder
214	Bearing jewel		

Dismantling PTO transmission and shift gears

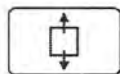

Preliminary work:

- Lower the rear power lift
- Drain transmission oil (approx. 67 l)
- Remove the trailer hitch
- Mark and unplug the X169 separation point at the B020 rear PTO stub shaft sensor
- Mark and unplug the X170 separation point at the B021 rear PTO clutch speed sensor
- Unscrew the compressed air couplings

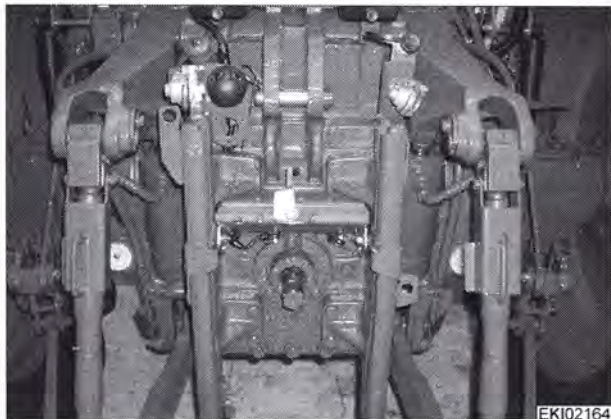

EKI02164

1003641

Fig. 42.

919 .. 0101-1000
919 .. 1001-
922 .. 0101-1000
922 .. 1001-
925 .. 0101-1000

925 .. 1001-
928 .. 0101-1000
928 .. 1001-
931 .. 0101-1000
931 .. 1001-

934 .. 0101-1000
934 .. 1001-

T001262
Version 1
07-11-2007

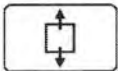

Unscrew all fixing bolts and nuts.
Remove the plugs from the threaded bores and screw in two jack screws M12 (arrows).
Secure the housing cover in the hoist and release the housing cover.

WARNING: Do not walk or stand under suspended loads!

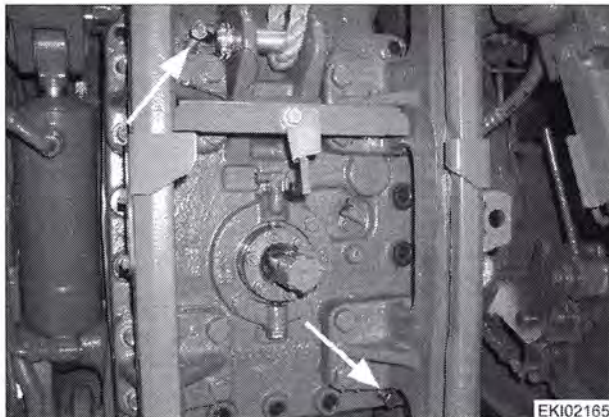
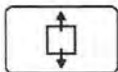

Fig. 43.

EKI02165
1003642



Remove the housing cover (with rear PTO).

NOTE: Take note of the shim (1).
The washer (1) is used to adjust the bearing play

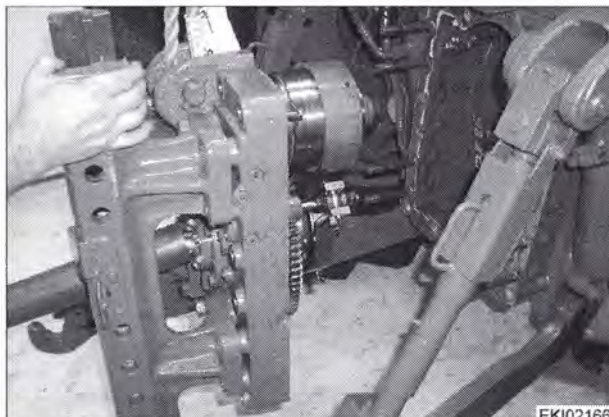
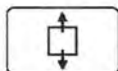

Fig. 44.

EKI02166
1003643



Dismantle the live PTO clutch

NOTE: See also:
Chapter 1220; Register G – Assembling and dismantling live PTO clutch

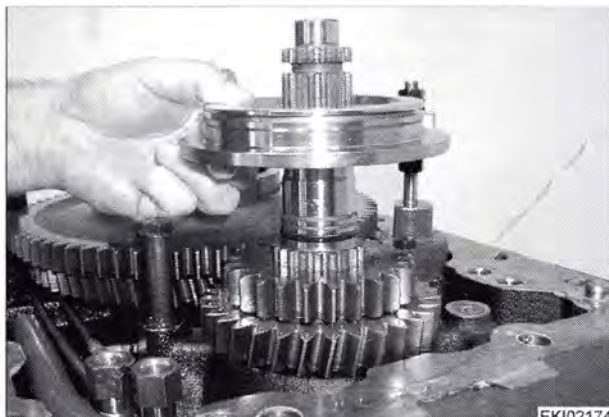
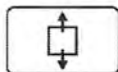

Fig. 45.

EKI02174
1003651



Dismantling the PTO transmission

Pull out the tapered roller bearing (101) with a standard extraction tool.
Remove the locating ring.

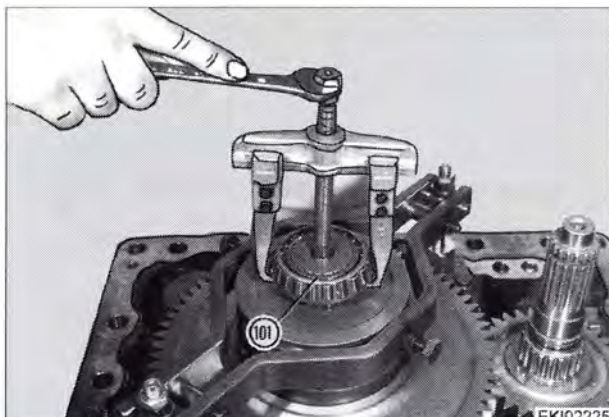
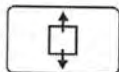

Fig. 46.

EKI02225
1003683



If required, note the adjustment value of the hex nut (210 and 211).

Unscrew the hex nuts (210 and 211).

Remove the stops (116).

Dismantle the shift gear.

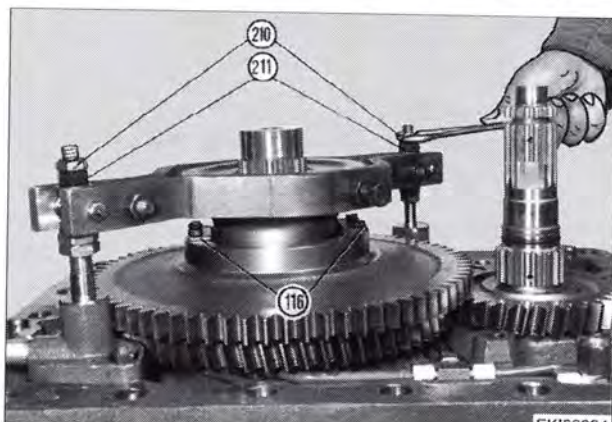
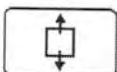

Fig. 47.

EKI02224
1003684



Remove the spur gears (118) and (118a).

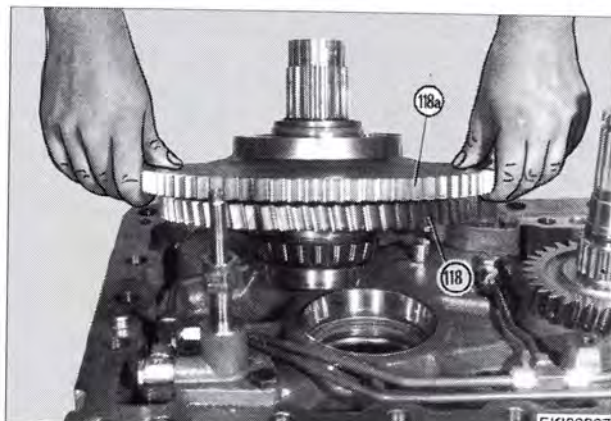
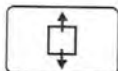

Fig. 48.

EKI02227
1003685



Remove the shaft (35).

If required, push out the outer bearing rings.

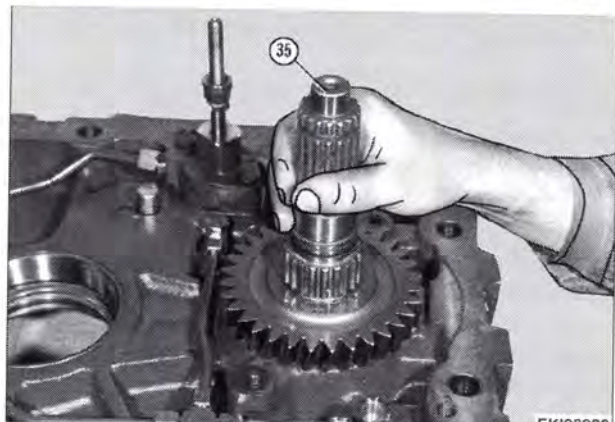
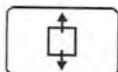

Fig. 49.

EKI02228
1003686



If required, dismantle the cylinder (217) and/or cylinder (226).

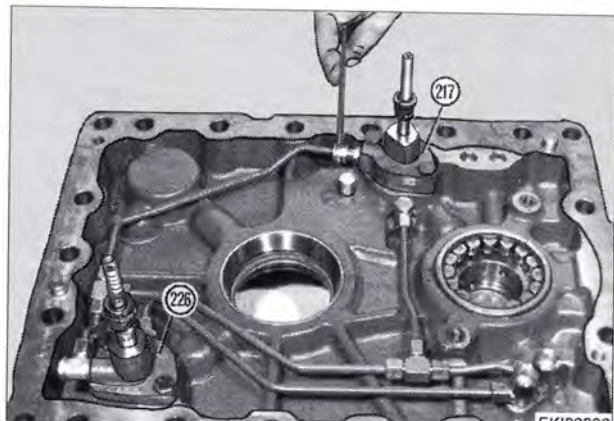

Fig. 50.

EKI02229
1003687

919 .. 0101-1000
919 .. 1001-
922 .. 0101-1000
922 .. 1001-
925 .. 0101-1000

925 .. 1001-
928 .. 0101-1000
928 .. 1001-
931 .. 0101-1000
931 .. 1001-

934 .. 0101-1000
934 .. 1001-

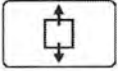

Snap out the circlip (107).
Remove the washer (108) and the spur gears

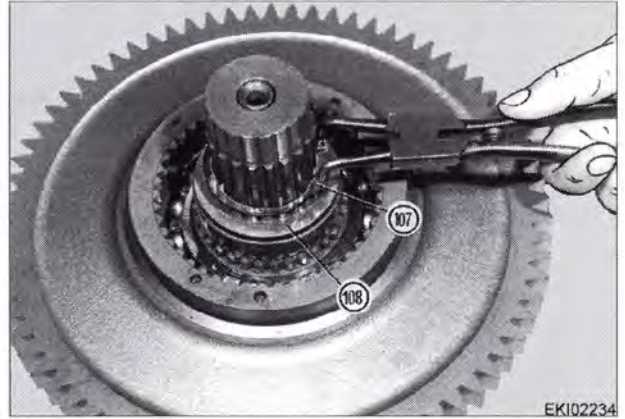
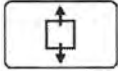

Fig. 51.

EK102234
1003688



Snap out the circlip (112).
Press out the spur gear (118).

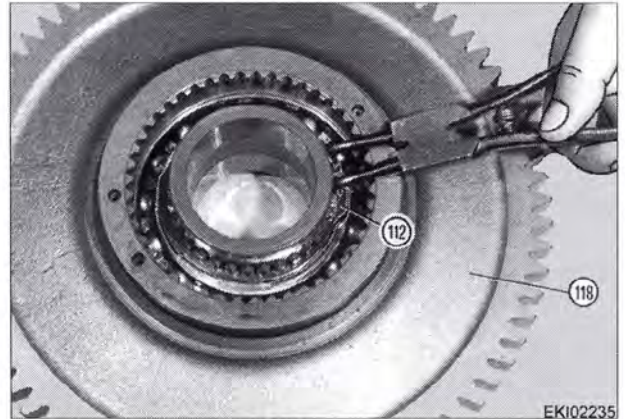
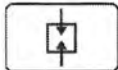

Fig. 52.

EK102235
1003689

Assembling PTO transmission and shift gears



Assemble the PTO transmission

Press the deep-groove ball bearing (113) until it fits into the spur gear (118a).
Put the circlip (114) in place.
Thereafter, press the spur gear (118) until it falls in place

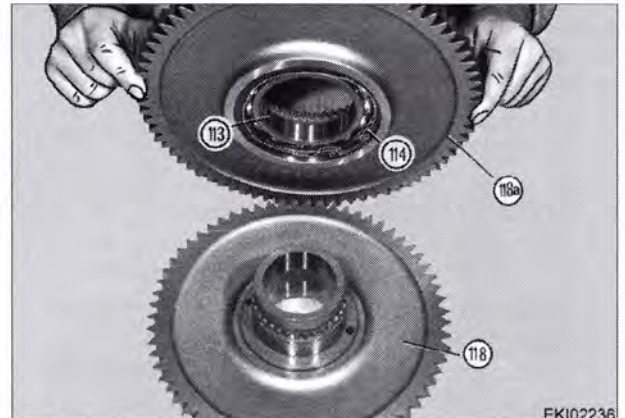
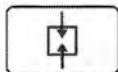

Fig. 53.

EK102236
1003690



Put the circlip (112) in place on the opposite side.

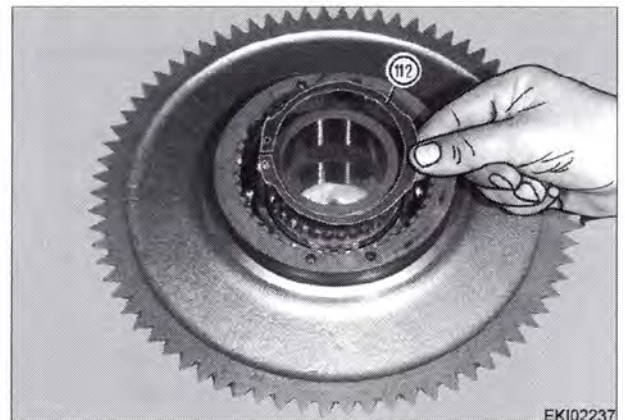
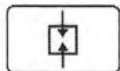

Fig. 54.

EK102237
1003691



Press the inner ring of the tapered roller bearing (123) on to the shaft (120).
 Fit the washer (122).
 Put the circlip (121) in place.
 Grease two setscrews (125) with X 903.050.084 synthetic bonding agent and turn them until they reach the inner ring of the tapered roller bearing (123).
 Washer (122) must become tight.

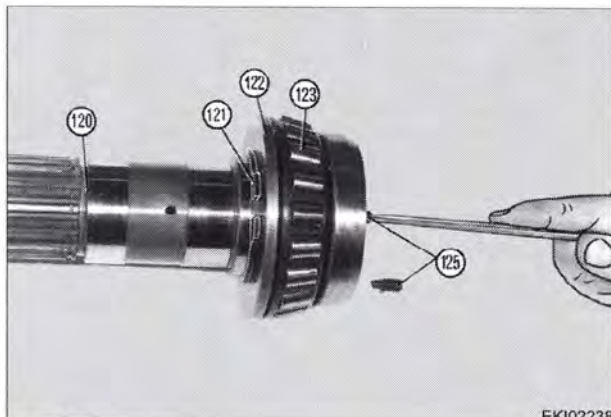
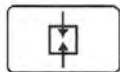

Fig. 55.

EKI02238
1003692



Thread the needle bearing (109), spacer (110) and needle bearing (109) onto the shaft (120).
 Insert the shaft (120).
 Fit the washer (108).
 Put the circlip (107) in place.

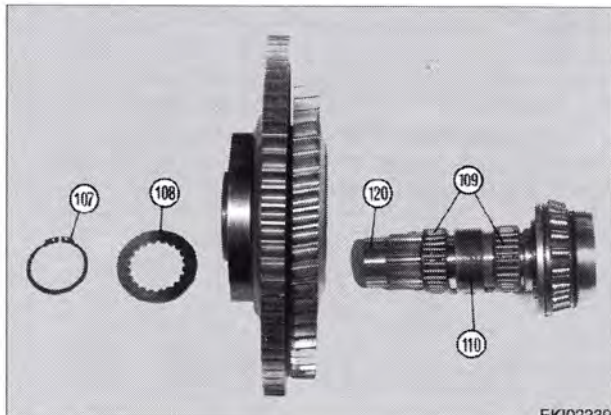
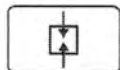

Fig. 56.

EKI02239
1003693



Place the new compact seal rings (219) in the cylinder (217).
 Place the new O-ring (218) in the groove of the cylinder (217).
 Grease the sealing elements.
 Insert the piston (222) with the pressure spring (221) in the manner shown in the cylinder (217).

NOTE: The compact seal ring (219) consists of two parts, O-ring on the outside and a piston guide tape inside.

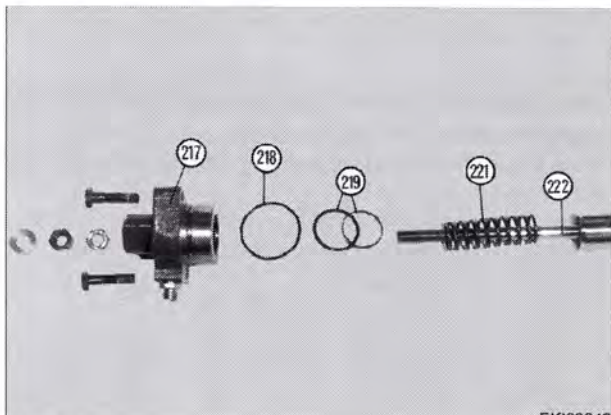
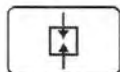

Fig. 57.

EKI02240
1003694



Place the new compact seal rings (220) in the cylinder (226).
 Place the new O-ring (218) in the groove of the cylinder (226).
 Grease the sealing elements.
 Insert the piston (224) with the pressure spring (221) in the manner shown in the cylinder (226).

NOTE: The compact seal ring (220) consists of two parts, O-ring on the outside and a piston guide tape inside.

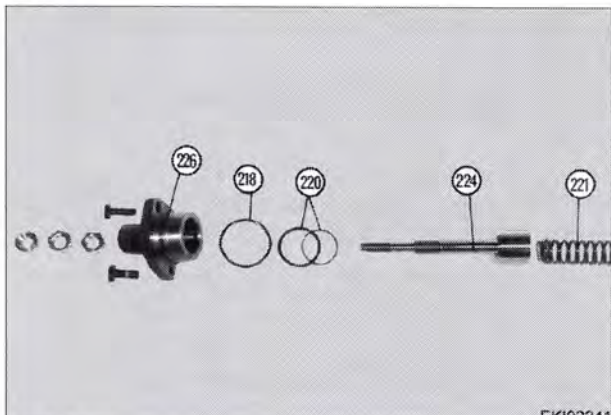

Fig. 58.

EKI02241
1003695

919 .. 0101-1000
 919 .. 1001-
 922 .. 0101-1000
 922 .. 1001-
 925 .. 0101-1000

925 .. 1001-
 928 .. 0101-1000
 928 .. 1001-
 931 .. 0101-1000
 931 .. 1001-

934 .. 0101-1000
 934 .. 1001-

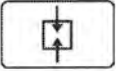

Fit cylinder (217) and cylinder (226).

Coat the threads of the hex screw (216) and (225) with X903.050.084 synthetic bonding agent and tighten them with a torque of **49 Nm**.

Fit the hydraulic lines that have been dismantled in the housing cover (316).

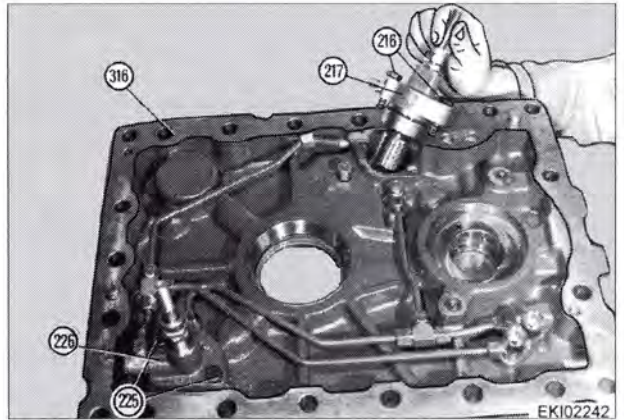
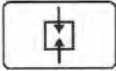

Fig. 59.

EKI02242
1003696

If a new housing cover (316) is being fitted, turn the nozzle (29) in the threaded bore until it is in place.

Press the outer bearing rings of the cylinder roller bearing (36) in until they are in place.

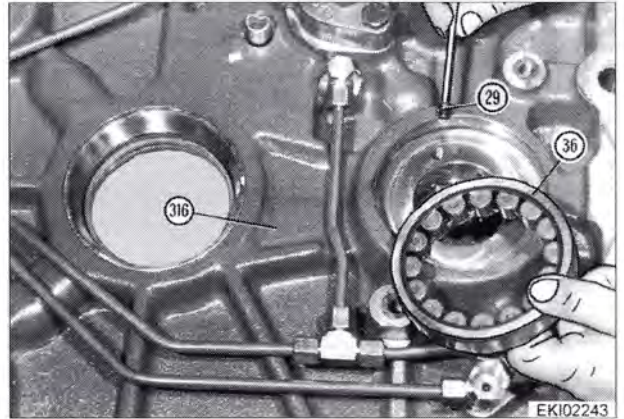
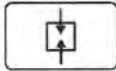

Fig. 60.

EKI02243
1003697

Insert, lock and grease two new rectangular-section rings (37) in the grooves of the shaft (35).

Press the inner bearing rings of the cylinder roller bearing (36) until they are in place.

When fitting a new shaft (35), coat the setscrews (38) with X903.050.084 synthetic bonding agent and turn them until they are in place.

Screw in the nozzle (29) until it is in place.

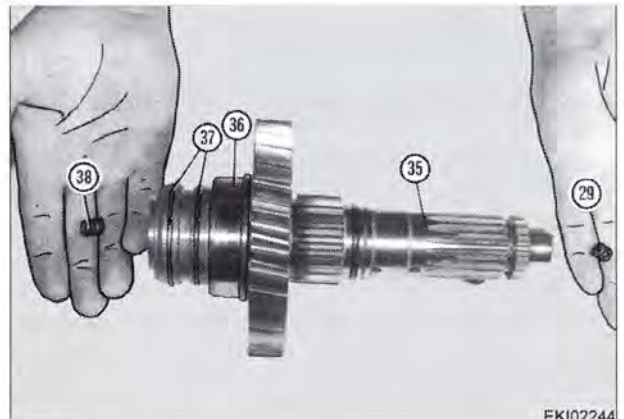
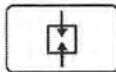

Fig. 61.

EKI02244
1003698

Place the pre-assembled shaft (35) in the housing cover (316).

Where removed:

Fit the existing shims (124) and press the outer bearing ring of the tapered roller bearing (123) until it is in place.

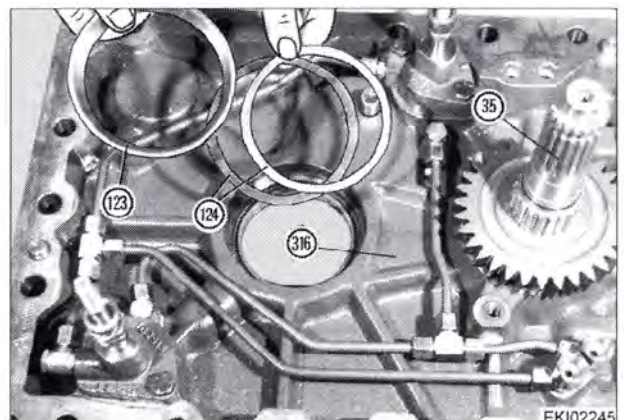
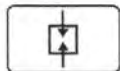

Fig. 62.

EKI02245
1003699



Insert the pre-assembled pair of wheels and spur gear (25).

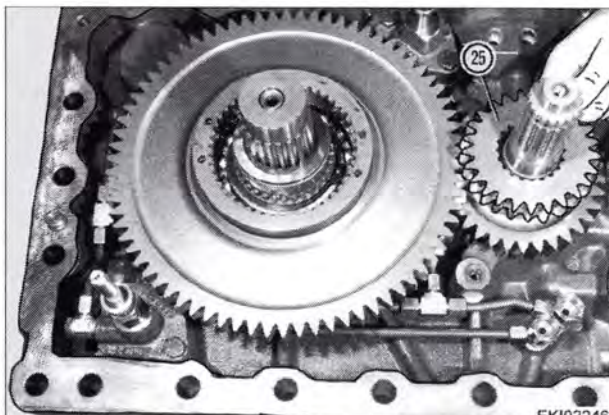
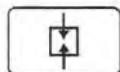

Fig. 63.

EKI02246
1003700



Fit the pre-assembled strap (201)

Coat the threads of the hex screw (205) with X903.050.084 synthetic bonding agent.
Fit the spacers (207) and bearing jewels (214).
Tighten the hex nuts (206).

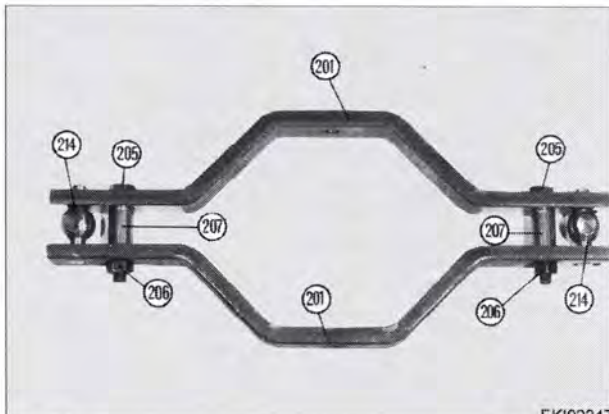
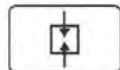

Fig. 64.

EKI02247
1003701



Insert the sliders (105) in the clutch body (104).
Coat the stud bolt threads (203) with synthetic bonding agent X903.050.084.
Adjust the strap (201) so that it is equidistant and has no play.
Subsequently, turn each stud bolt (203) back by about **1/6 revolution** and lock it in this position.

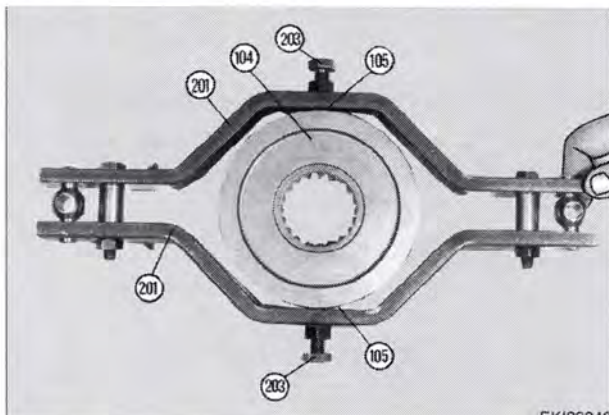
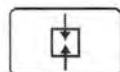

Fig. 65.

EKI02248
1003702



Screw the hex nuts (210), (211) and (213) onto the piston rods (222) and (224).
Place the washers (212) with the depression facing upwards.

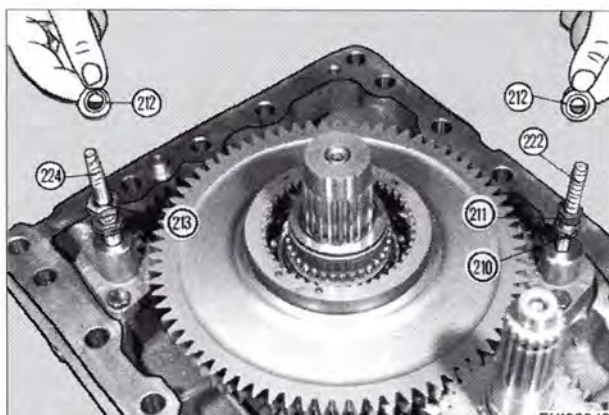

Fig. 66.

EKI02249
1003703

919 .. 0101-1000
919 .. 1001-
922 .. 0101-1000
922 .. 1001-
925 .. 0101-1000

925 .. 1001-
928 .. 0101-1000
928 .. 1001-
931 .. 0101-1000
931 .. 1001-

934 .. 0101-1000
934 .. 1001-

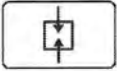

Insert the pre-assembled strap (201).
Place the washer (212) with the depression facing downwards.
Fit the hex nuts (211) and (210).

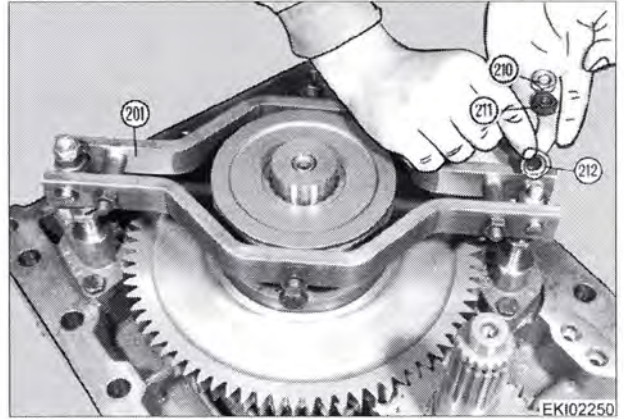
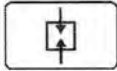

Fig. 67.

EKI02250
1003704

Coat the threads of the hex screw (115) with
X903.050.084 synthetic bonding agent.
Place the stops (116) and tighten the hex screws (115).

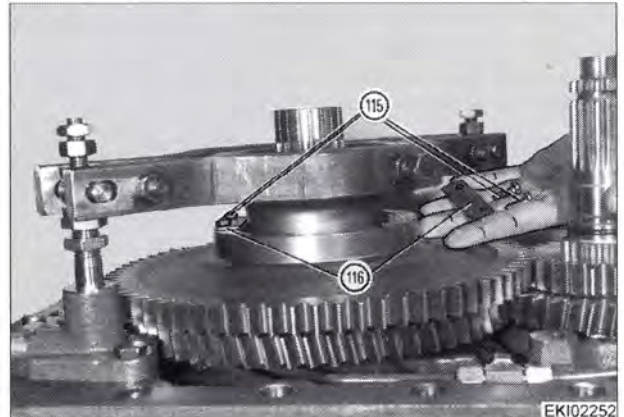
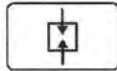

Fig. 68.

EKI02252
1003705

Prior to adjusting the travel, please ensure that:

The slot in the strap (201) is facing the cylinder (226).
Screw the hex nut (213) completely onto the piston rod of
the cylinder (226).
Screw on the hex nuts (211) and (210) until they are in
place and lock them.

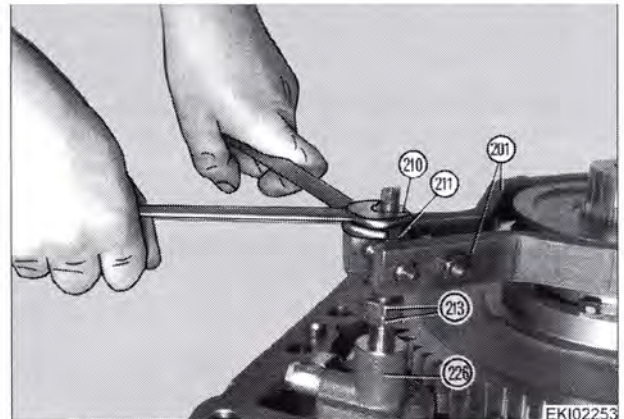
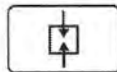

Fig. 69.

EKI02253
1003706

Adjust the shift to 750 rpm or 540 rpm

Screw the ring nut M12 (self-made) onto the piston rod of
the cylinder (217).
Pull out the piston rod with the help of the hoist until it
reaches the stop position. (Shift position 750 or 540 rpm)
Check the play of the clutch body (104).
Target value: 0.1 mm ... 0.2 mm (play)

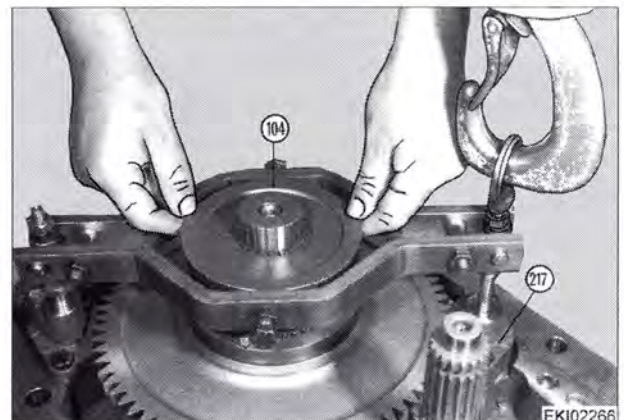
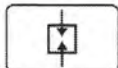

Fig. 70.

EKI02266
1003707



In case of deviations:

Change the adjusting nuts M12 above and below until the play is 0.1 mm ... 0.2 mm .

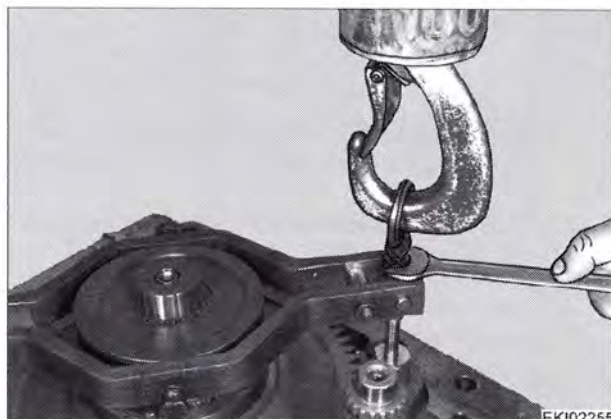
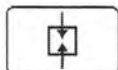

Fig. 71.

EKI02255
1003708



Remove the hoist.
Unscrew the ring nut M12 (self-made).
Tighten the hex nuts.

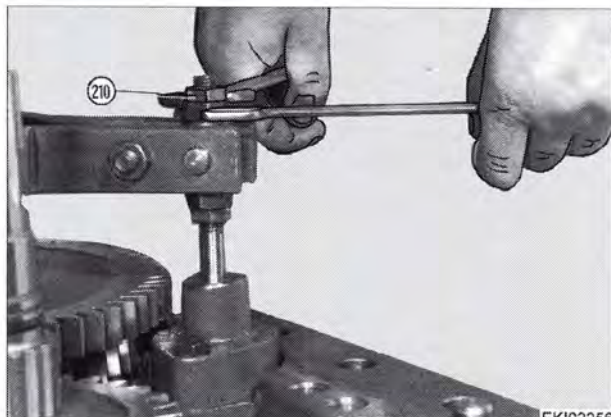
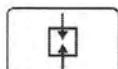

Fig. 72.

EKI02256
1003709



Set the shift to 1000 rpm

Press in the piston rod of the cylinder (226) using a vice until the hex nuts (213) are in place. (Stroke limit, switch position 1000 rpm)

Check the play of the clutch body (104).

Target value: 0.1 mm ... 0.2 mm (play)

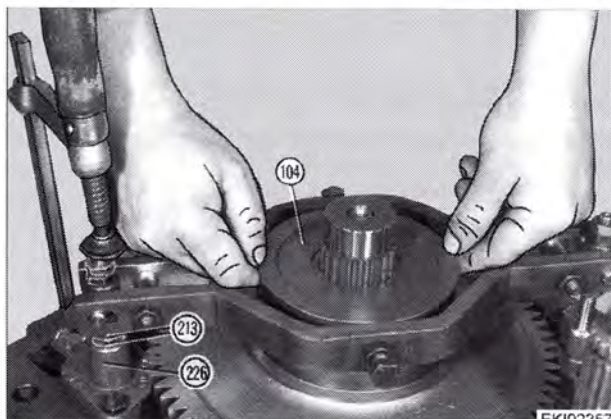
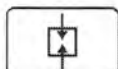

Fig. 73.

EKI02257
1003710



In case of deviations:

Change the hex nuts (213) and lock them until the play is 0.1 mm ... 0.2 mm .

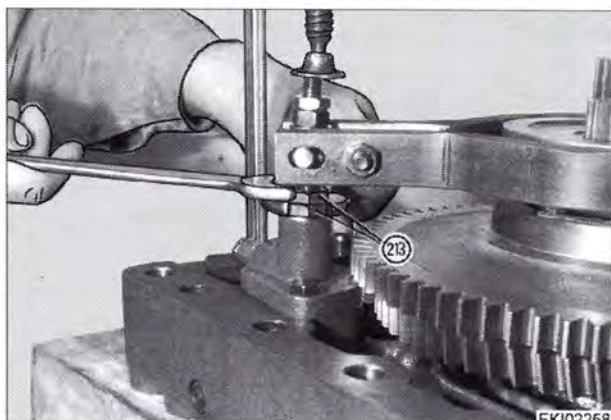
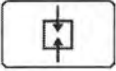

Fig. 74.

EKI02258
1003711



Remove the vice.

The shift gear latches in the "Neutral" position

The spur gears of the gear position 750 or 540 and 1000 must be free to turn.

The free travel of the shift gear must be the same in both the up and down directions.

If this is not the case repeat the adjustment.

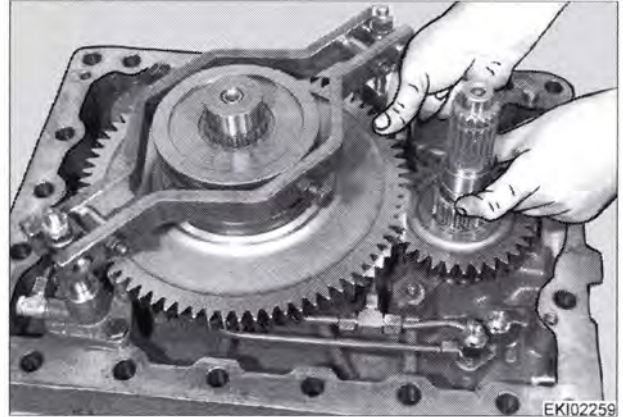
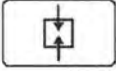

Fig. 75.

EK102259
1003712



Fit the location ring (102).

Press the inner ring of the tapered roller bearing (101) until it fits into place on the shaft (120).

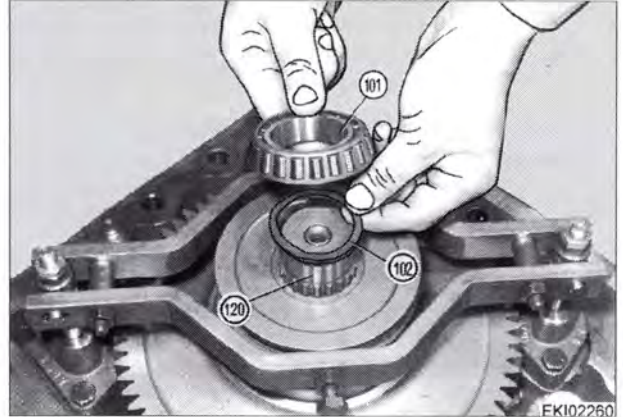
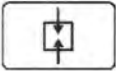

Fig. 76.

EK102260
1003713



Fit the spur gear (25).

Place the new O-ring in the groove of the shaft (35) and grease it.

Check the brake disc (20) for damage.

If necessary, fit a new brake disc (20).

For details regarding clutch assembly, please see: Chapter 1220; Register G – Assembling and dismantling live PTO clutch

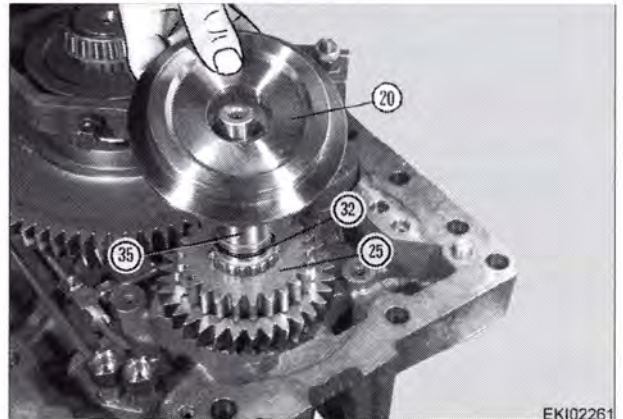
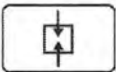

Fig. 77.

EK102261
1003714



Align the externally toothed discs (12) and press on the bell housing (3) until they fit in place.

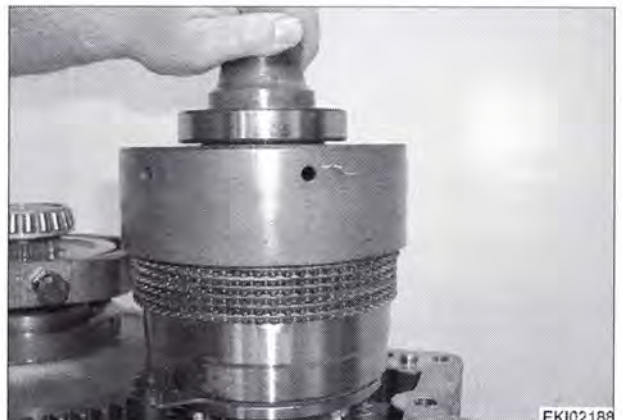
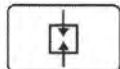

Fig. 78.

EK102188
1003673



Adjust the play on the bearing of the bell housing (3)

Fit the existing shim (1) or the shim (1) on the deep-groove ball bearing (2).
 Measure and record the distance to the flange surface.
 E.g. 178.6 mm

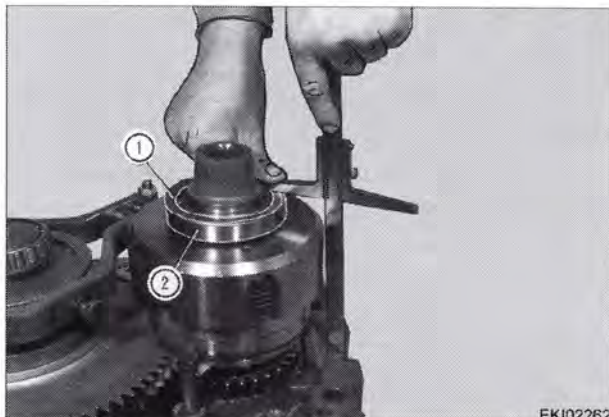
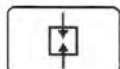

Fig. 79.

EKI02262
 1003727



The size of the bearing contact surface with the flange surface is indicated in white colour at the top of the rear axle housing.
 E.g. 178.71

The size of the deep-groove ball bearing (2) washer to the flange surface of the housing cover must be smaller by 0.1 mm ... 0.2 mm than the size indicated.

This means that the bearing must have a play of 0.1 mm ... 0.2 mm .

In the event of deviations, correct it using a shim (1).

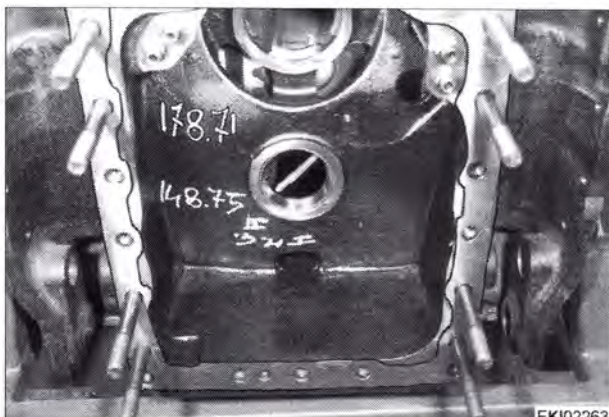
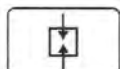

Fig. 80.

EKI02263
 1003716



The size of the lower shaft from the bearing entry flange to the flange surface is given in white colour below in the rear axle housing,
 e.g. 148.75.

NOTE: This dimension is not required for repair, since a gauge is required to measure the play in the bearing.
 Check the play in the bearing of the lower shaft (120):
 Please refer to the detailed description

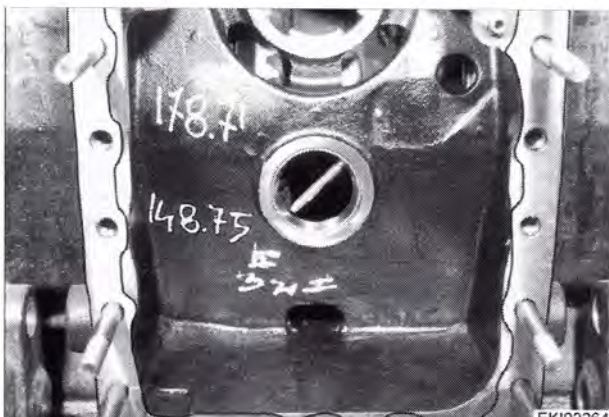
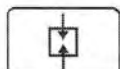

Fig. 81.

EKI02264
 1003717



Place the shims (1) in the upper bore.
 Fit and grease four new O-rings for the pressure connections.

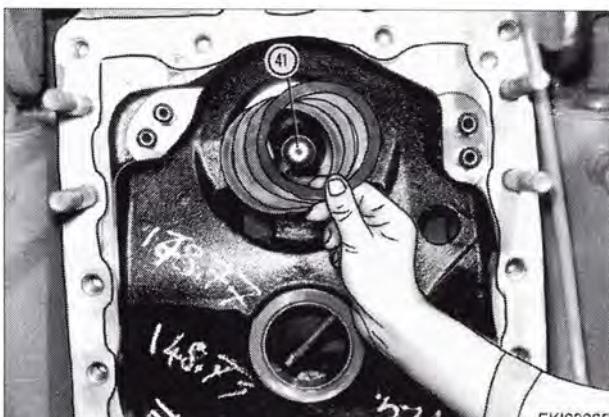

Fig. 82.

EKI02265
 1003718

919 .. 0101-1000
 919 .. 1001-
 922 .. 0101-1000
 922 .. 1001-
 925 .. 0101-1000

925 .. 1001-
 928 .. 0101-1000
 928 .. 1001-
 931 .. 0101-1000
 931 .. 1001-

934 .. 0101-1000
 934 .. 1001-

T001262
 Version 1
 07-11-2007

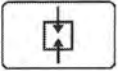

Secure the housing cover in the hoist and fit the rear axle housing.

WARNING: Do not walk or stand under suspended loads!

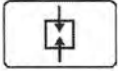

Tighten the fixing bolts and nuts M18 with 400 Nm .

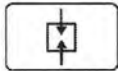

Where removed:

Coat the new shaft seal ring (126) externally with a thin layer of X903.051.711 sealing agent - with the lip seal facing the oil chamber - press it into the bearing cover (128) until it is in place.

(offset approx. 5 mm)

Fill sealing lips 2/3 with grease.

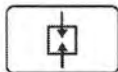

Adjust the play of the shaft (120)

Put the existing shims (124) in place.

Place the new O-ring (127) in the notch of the bearing cover (128) and grease it.

Coat the threads of the hex screws (129) with X 903.050.084 synthetic bonding agent and tighten them.

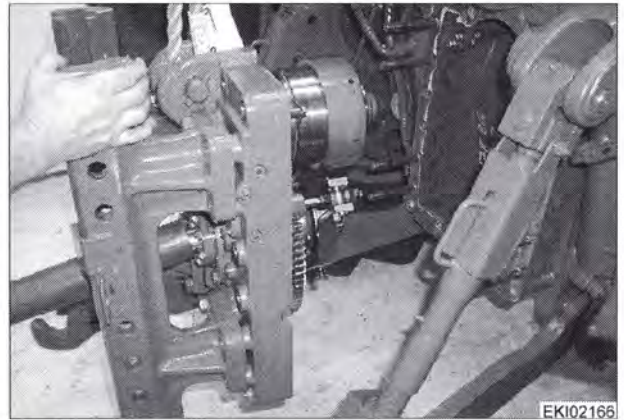

Fig. 83.

EKI02166
1003643

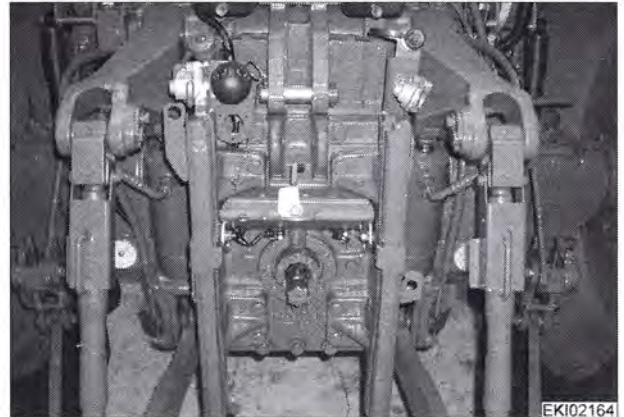

Fig. 84.

EKI02164
1003641



Fig. 85.

EKI02195
1003719

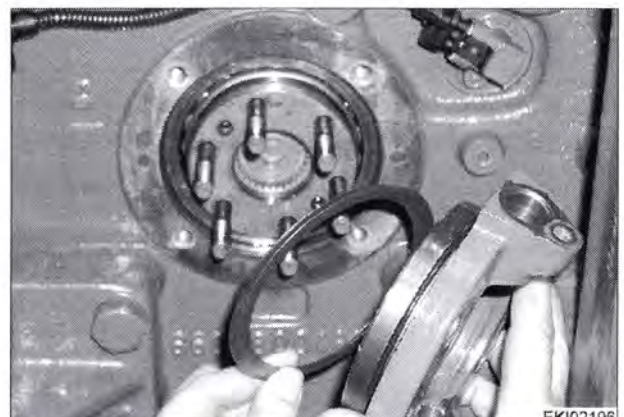
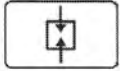

Fig. 86.

EKI02196
1003720



Turn the shaft (120) approx. 10 times.
 Attach gauge.
 Press in the shaft (120) once and observe the play.

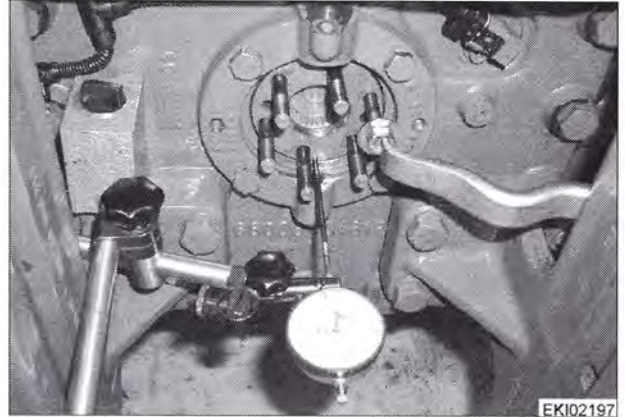
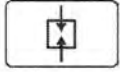

Fig. 87.

EKI02197
 1003721



Turn the shaft (120) approx. 10 times.
 Attach gauge.
 Pull back the shaft (120) once and observe the play.
Total play = play, shaft (120) pressed in + play, shaft (120) pulled back

Target value: 0.02 mm ... 0.07 mm (play)
 In the event of deviations, correct using shims (124).

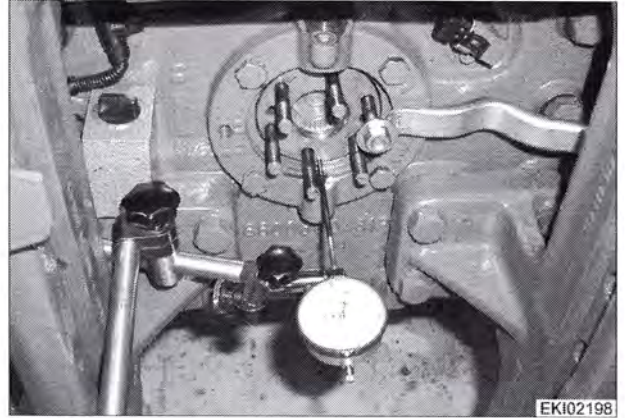
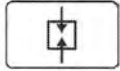

Fig. 88.

EKI02198
 1003722



Flanged pin splined shaft 6-part 1 3/8" or:
 Flanged pin involute 21-part 1 3/8"
 Flanged pin splined shaft 6-part 1 3/4"
 Flanged pin involute 20-part 1 3/4"

NOTE: The flange pin has four impulse bores (arrow) for the B020 rear PTO stub shaft sensor

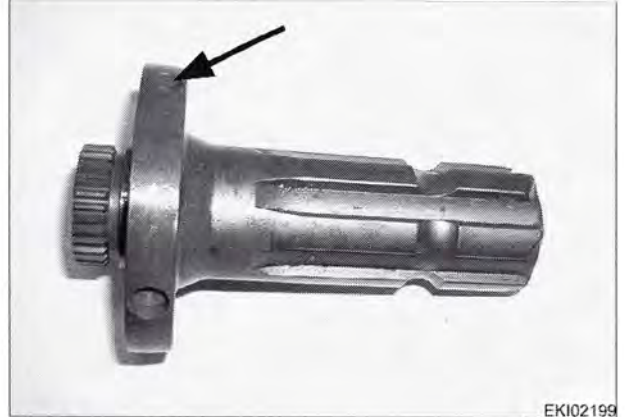
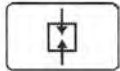

Fig. 89.

EKI02199
 1003723



Put the flange pin (137) in place.
 Fit the spacer (132).

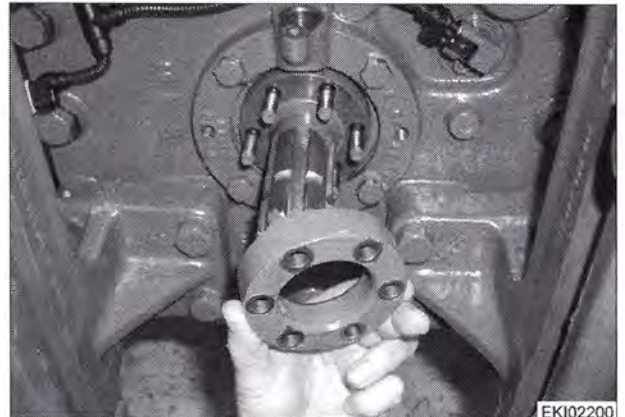
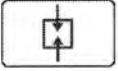

Fig. 90.

EKI02200
 1003724

919 .. 0101-1000	925 .. 1001-	934 .. 0101-1000
919 .. 1001-	928 .. 0101-1000	934 .. 1001-
922 .. 0101-1000	928 .. 1001-	
922 .. 1001-	931 .. 0101-1000	
925 .. 0101-1000	931 .. 1001-	



Clamp the flange pin (137) tight with screw M16 (arrow).
 (Assembly kit)
 Tighten the hex nuts (134) (M10 - 10) with 69 Nm .
 Replenish transmission oil.

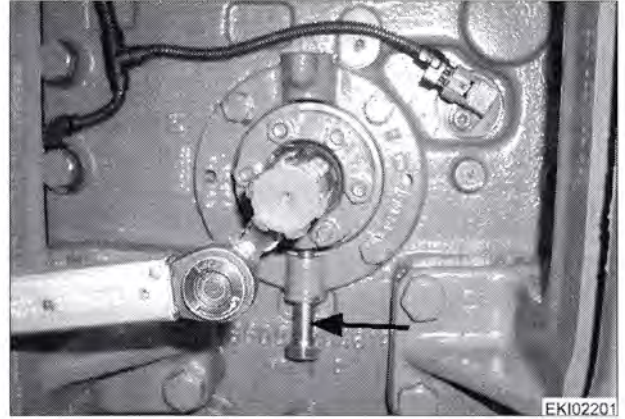

Fig. 91.