

FENDT

Werkstatthandbuch

Workshopmanual

Manuel d'atelier

Manual de taller

Manuale per l'officina

Werkplaatshandboek

FENDT 900 Vario COM III

X 990.005.057.012

1

FENDT

A	General
B	Faults
C	Documents and Diagrams
D	Component location
E	Testing
F	Setting and Calibration
G	Repair
H	Service – Info

2010

Engine/cylinder head

FENDT 900 Vario - COM III

Volume 1

0000	Overall system/tractor
1005	Overall system/transmission
1010	Transmission/differential
1015	Transmission/axle drive
1050	Transmission/housing
1070	Transmission / Brake system
1080	Transmission/drive train
1200	Transmission/front PTO
1220	Transmission / Live PTO
1320	Transmission/front wheel drive
2000	Overall system/engine
2010	Engine/cylinder head
2050	Engine/cooling
2060	Engine/fuel system
2210	Engine/crankcase
2312	Engine/lubrication
2400	Engine/exhaust system
2712	Engine/injectors
3000	Overall system/front axle
3120	Front axle/steering cylinder
3180	Front axle/cardan shaft

Volume 2

4000	Overall system/steering
4090	Steering system / hydraulic steering unit
5030	Vehicle layout/operator's seat
5500	Overall system/air conditioning system
8100	Overall system/cab
8610	Power lift/EPC electro-hydraulic control
8631	Power lift/hydraulic lift
8800	Overall system/compressed air system

Volume 3

9000	Overall system/electrical system
9015	Electrical system/starter lockout

FENDT 900 Vario - COM III

Volume 4

- 9410 Hydraulic pump installation/LS pump**
- 9430 Hydraulic pump installation/steering pump**
- 9534 Hydraulic piping/"Rüfa"reverse operation**
- 9600 Overall system/hydraulic equipment**
- 9605 Hydraulic equipment/hydraulic connections**
- 9610 Hydraulic equipment/central control block (ZSB)**
- 9620 Hydraulic equipment/valve fitting**
- 9700 Overall system/electronics**
- 9920 Service/special tools**
- 9975 Service/SERDIA - Deutz engine diagnostics program**

2010 Engine/cylinder head

G **Repair.5**

G Repair

1 Adjusting valves (Deutz engine) 7

1 Adjusting valves (Deutz engine)

Tractor series (selection)	Engine series	Valve clearance (with a cold engine, temperature below 80 °C)		Locknut tightening torque	Adjustment tool
		Inlet valve	Exhaust valve		
Tractors with Deutz engine ("Common Rail" high-pressure accumulator)					
Note: 1. Cylinder on flywheel					
FENDT 900 Vario COM3	TCD 2013 L6 V4	75°	105°	20 Nm	X899.980.236.030

X899.980.236.030 adjustment tool

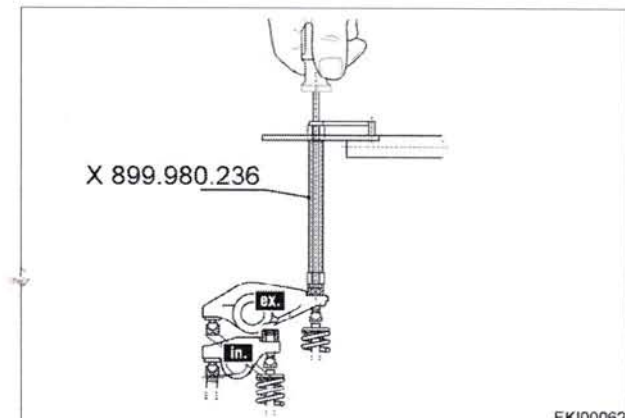

Fig. 1.

EKI00062
1002479

Cylinder numbering (Deutz engine)

The cylinders are counted starting from the flywheel.

The rotational direction of the engine is to the left, when looking at the flywheel (counterclockwise).

Firing sequence, 6-cylinder engine = 1 - 5 - 3 - 6 - 2 - 4

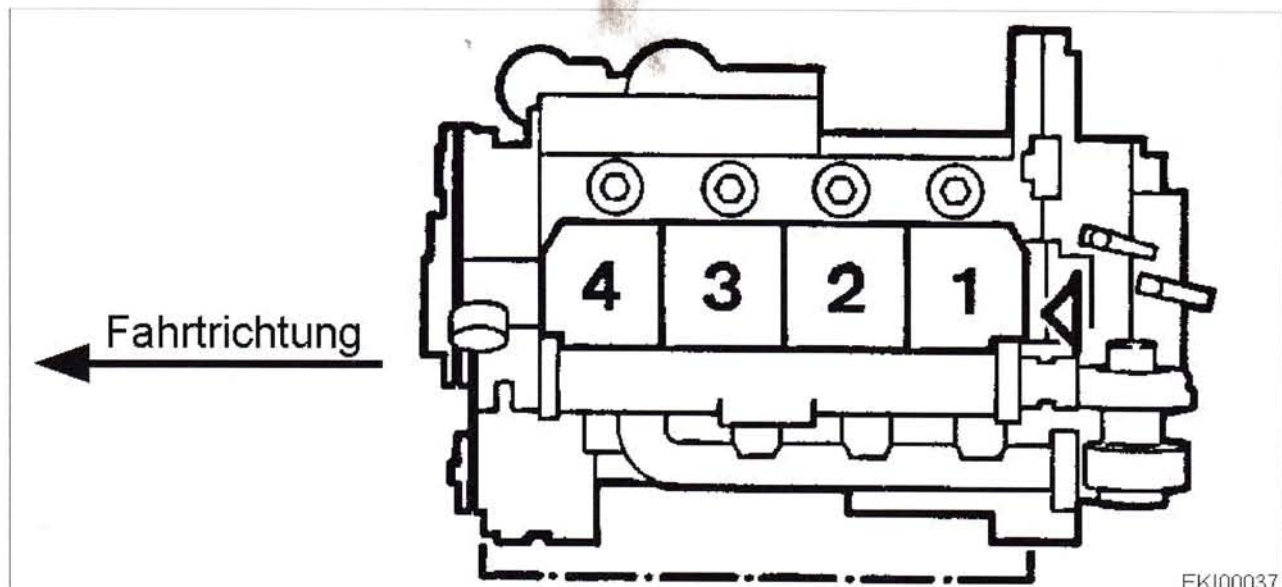

Fig. 2.

EKI00037
1002480

Adjusting valve clearance (FENDT 900 Vario COM3 / Deutz TCD 2013)

See engine sign plate for engine type.

NOTE: See also:

- Technical datasheets
- Maintenance schedule

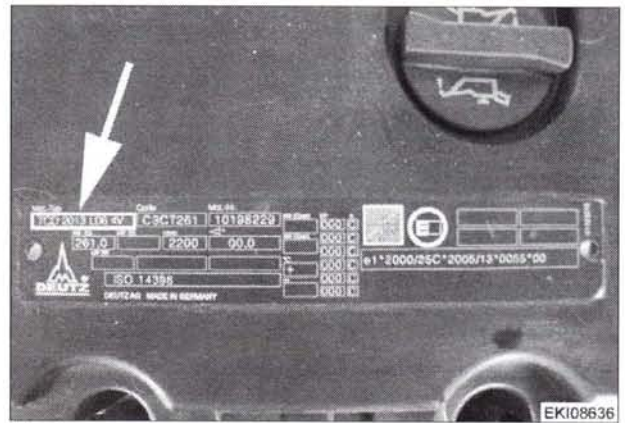
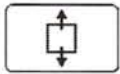

Fig. 3.

EKI08636
1002481



Remove fixing bolts from K063 heater flange relay
Put K063 heater flange relay to one side

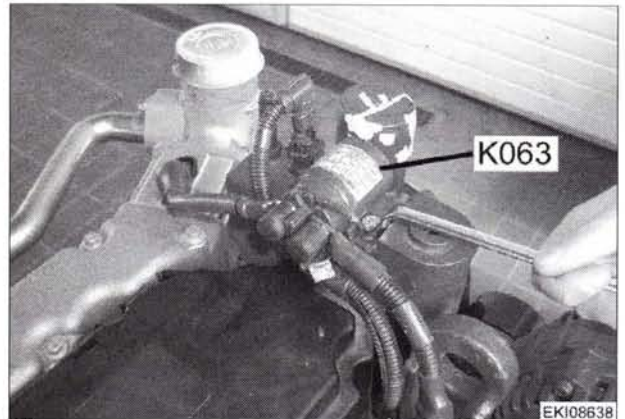
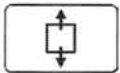

Fig. 4.

EKI08638
1002484



Remove the engine ventilation

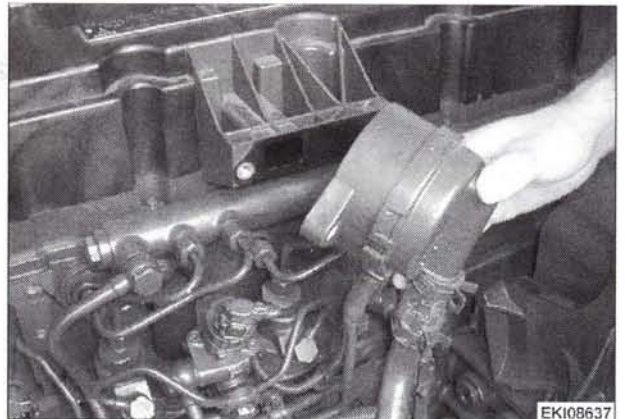
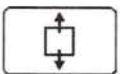

Fig. 5.

EKI08637
1002482



Remove the valve cover

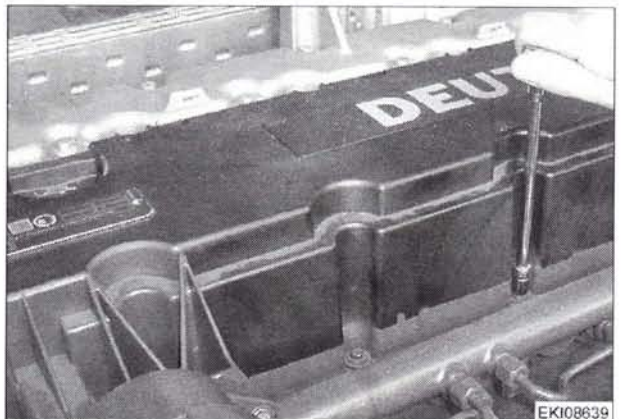
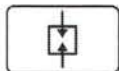

Fig. 6.

EKI08639
1002483



EX = exhaust valve
IN = inlet valve

0,30
0,50

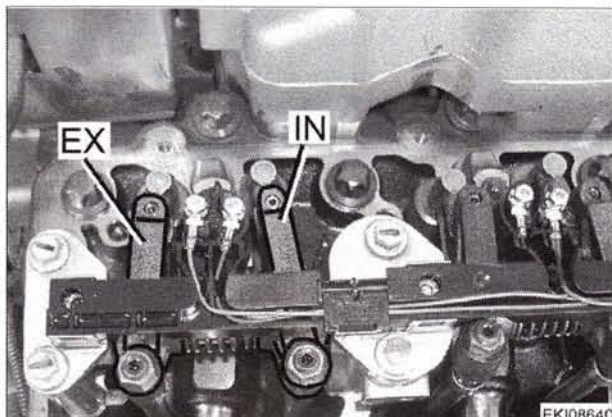
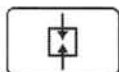

Fig. 7.

EKI08640
1002485



1 = rocker arm
2 = valve spring
3 = push rod
4 = adjustment screw with locknut

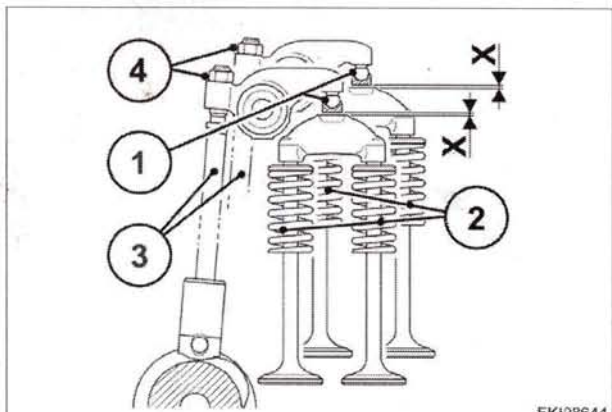
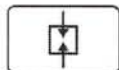

Fig. 8.

EKI08644
1002489



Rotate the engine on the G002 or G004 alternator

NOTE: The engine can only be turned against its rotational direction

Adjust valves according to valve adjustment diagram (see below)

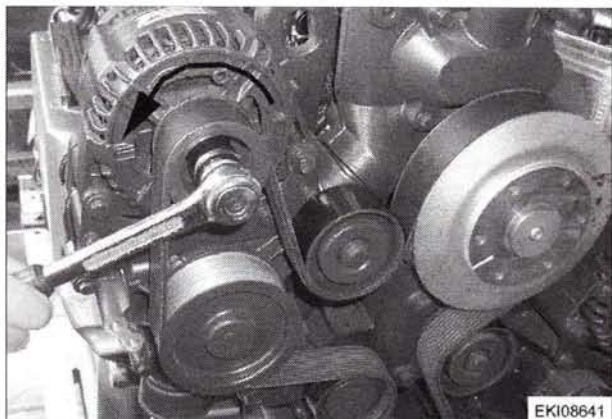

Fig. 9.

EKI08641
1002486

Valve adjustment diagram, engine rotating backwards

Note: Rotate the engine backwards on the G002/G004 alternator against its rotational direction

Crossover	6	3	5	1	4	2
Inlet valve closes						
Exhaust valve opens						
Adjust	1	4	2	6	3	5

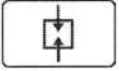

Position **X899.980.236.030** adjustment tool

Loosen locknut

Screw in the adjustment screw until the rocker arm lies directly on the valve with no clearance

Set the indicator to 0

Turn back the adjustment screw until the required clearance is achieved.

Inlet valve (IN) = in. (75°)

Exhaust valve (EX) = ex. (105°)

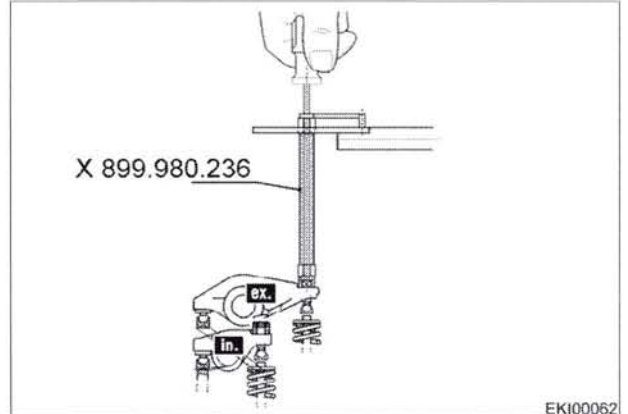
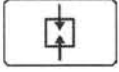

Fig. 10.

EKI00062
1002496



Hold the adjustment screw in place with the screwdriver.

Lock the adjustment screw using the internal serration spanner

Locknut tightening torque = 20 Nm

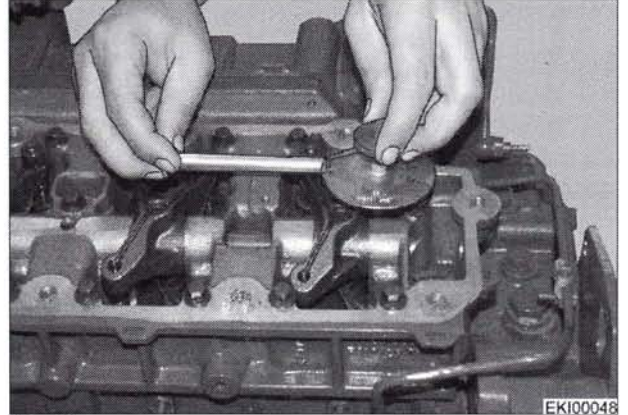
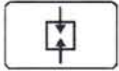

Fig. 11.

EKI00048
1002499



Clean sealing surfaces and seals of valve cover

Tighten valve cover uniformly

Tightening torque = 8,5 Nm

NOTE: Ensure the seals are in the correct position.
Seals can be used more than once if they are not damaged.

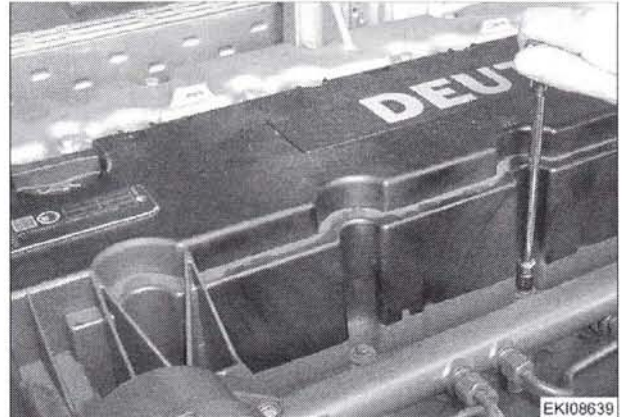
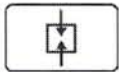

Fig. 12.

EKI08639
1002483



Refit engine ventilation

Tightening torque = 20 Nm

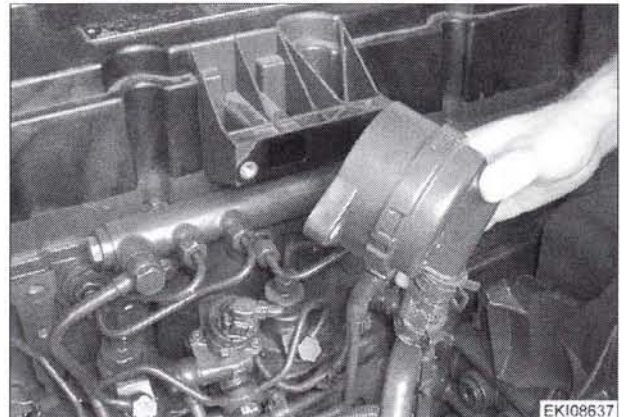
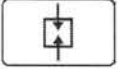

Fig. 13.

EKI08637
1002482



Refit the K063 heater flange relay

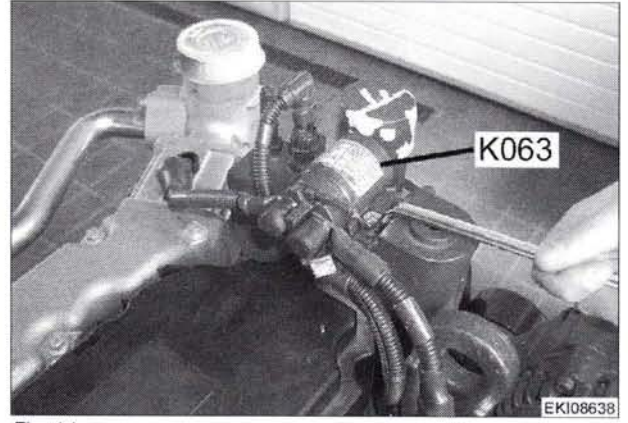

Fig. 14.

