

FENDT

Werkstatthandbuch

Workshopmanual

Manuel d'atelier

Manual de taller

Manuale per l'officina

Werkplaatshandboek

FENDT 900 Vario COM III

X 990.005.057.012

1

FENDT

A	General
B	Faults
C	Documents and Diagrams
D	Component location
E	Testing
F	Setting and Calibration
G	Repair
H	Service – Info

2050

Engine/cooling

FENDT 900 Vario - COM III

Volume 1

0000	Overall system/tractor
1005	Overall system/transmission
1010	Transmission/differential
1015	Transmission/axle drive
1050	Transmission/housing
1070	Transmission / Brake system
1080	Transmission/drive train
1200	Transmission/front PTO
1220	Transmission / Live PTO
1320	Transmission/front wheel drive
2000	Overall system/engine
2010	Engine/cylinder head
2050	Engine/cooling
2060	Engine/fuel system
2210	Engine/crankcase
2312	Engine/lubrication
2400	Engine/exhaust system
2712	Engine/injectors
3000	Overall system/front axle
3120	Front axle/steering cylinder
3180	Front axle/cardan shaft

Volume 2

4000	Overall system/steering
4090	Steering system / hydraulic steering unit
5030	Vehicle layout/operator's seat
5500	Overall system/air conditioning system
8100	Overall system/cab
8610	Power lift/EPC electro-hydraulic control
8631	Power lift/hydraulic lift
8800	Overall system/compressed air system

Volume 3

9000	Overall system/electrical system
9015	Electrical system/starter lockout

FENDT 900 Vario - COM III

Volume 4

- 9410** **Hydraulic pump installation/LS pump**
- 9430** **Hydraulic pump installation/steering pump**
- 9534** **Hydraulic piping/"Rüfa"reverse operation**
- 9600** **Overall system/hydraulic equipment**
- 9605** **Hydraulic equipment/hydraulic connections**
- 9610** **Hydraulic equipment/central control block
(ZSB)**
- 9620** **Hydraulic equipment/valve fitting**
- 9700** **Overall system/electronics**
- 9920** **Service/special tools**
- 9975** **Service/SERDIA - Deutz engine diagnostics
program**

2050 Engine/cooling

A	General.....	5
G	Repair.....	17

A General

1	Coolant circuit: Deutz TCD 2013	7
2	B077 electrical viscous fan	13

1 Coolant circuit: Deutz TCD 2013

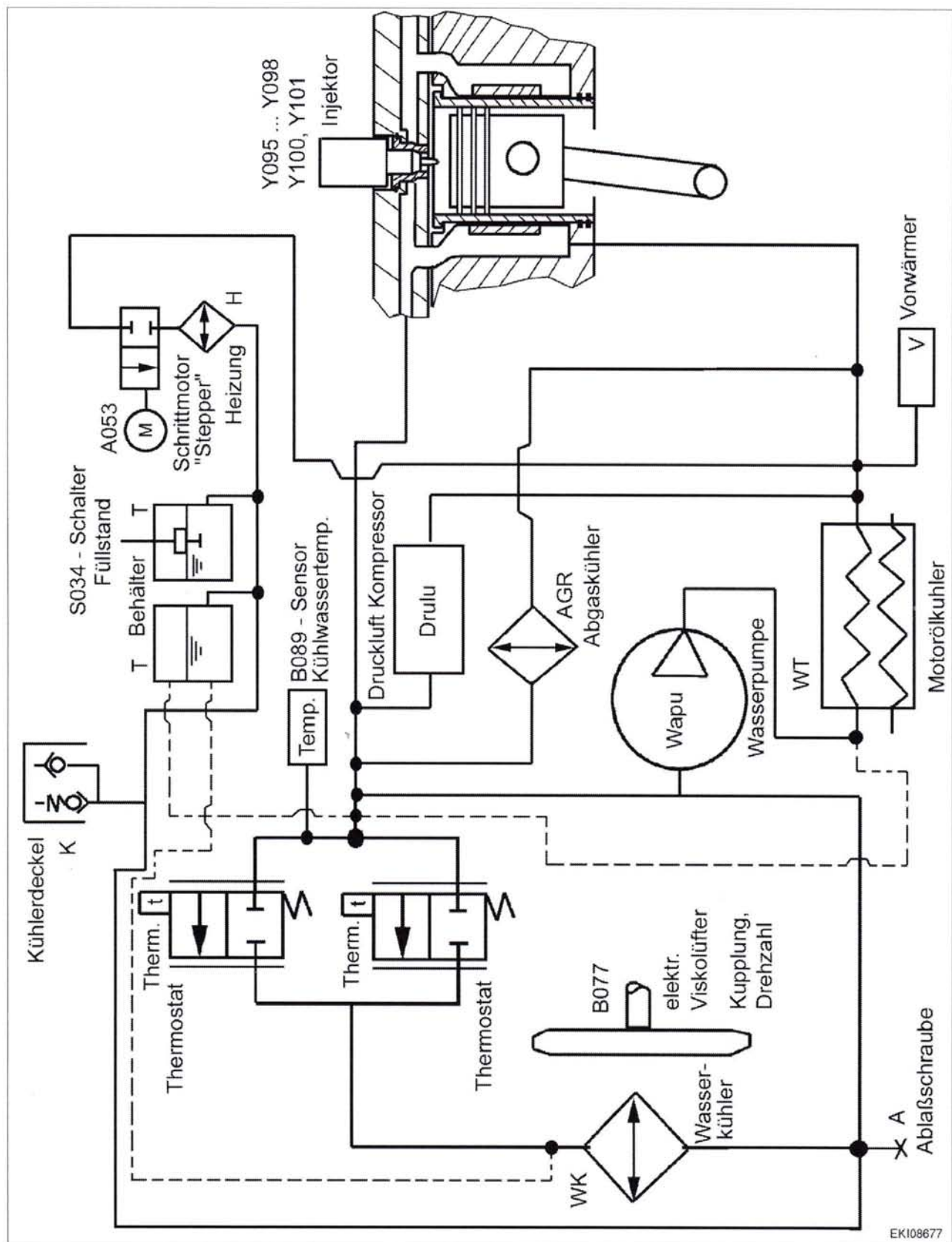

Fig. 1.

EKI08677

1002720

919 .. 0101-1000
919 .. 1001-
922 .. 0101-1000
922 .. 1001-
925 .. 0101-1000

925 .. 1001-
928 .. 0101-1000
928 .. 1001-
931 .. 0101-1000
931 .. 1001-

934 .. 0101-1000
934 .. 1001-

T000833
Version 1
07-11-2007

Item	Designation	Item	Designation
Wapu	Water pump	B089	Water temperature sensor Note: See also: Chapter 9000 Reg. E - Measuring and testing the B089 water temperature sensor
WT	Engine oil cooler (heat exchanger)	K	Cooler cover: Important: Do not open the cooler cover unless the engine is cold!
V	Coolant pre-heater (optional)	T	Expansion tank Coolant fill capacity: Approx. 30 l Proportion of cooling system protective agent min./max.: 35/45 Vol%
Y095...Y098 Y100, Y101	Water-cooled injector (injector valve)	S034	Fill level sensor Note: See also: Chapter 9000 Reg. E - Measuring and testing S034 coolant level switch
Therm.	Thermostat Start of opening: 87°C Perm. constant temperature: 110°C	A053	Air conditioning unit (heater stepper motor, heat exchanger) Note: See also: Chapter 9000 Reg. E - A053 air conditioning unit (area: "Stepper" heater valve) Chapter 5500 Reg. G - Removing the air conditioning unit
WK	Water cooler (with water drain plug (A))	Drulu	Air compressor
B077	Electr. viscous fan Engine speed/fan speed ratio: 1.2 Slip at fully engaged viscous fan: Approx. 7% Max. viscous fan speed at rated speed: 2460 rpm Note: See also: Chapter 9000 Reg. E - Measuring and testing B077 electr. viscous fan	AGR	Exhaust gas recirculation (exhaust gas cooler) Note: See also: Chapter 9000 Reg. E - Y094 exhaust gas recirculation actuator motor

Component position

Wapu = water pump



At the front of the engine

NOTE: See also:

Chapter 2000 Reg. A - Belt drive: Deutz TCD 2013

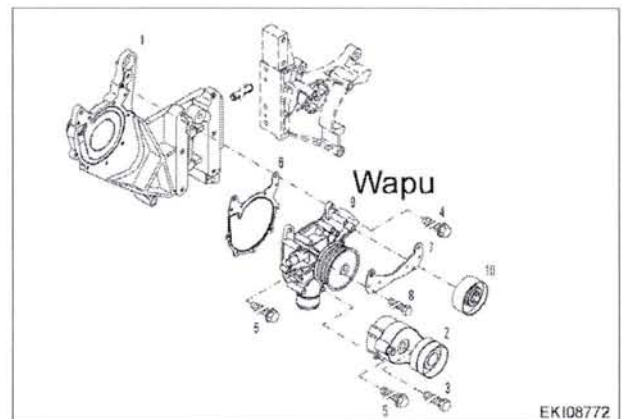

Fig. 2.

1002721

WT = engine oil cooler (heat exchanger)



On right side of engine

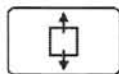

Remove the filter mount

NOTE: The heat from the engine oil is transferred to the coolant in the engine oil cooler.
The engine oil is cooled to approx. 120...130°C.
When the engine is cold, the cold engine oil is heated by the warm coolant.

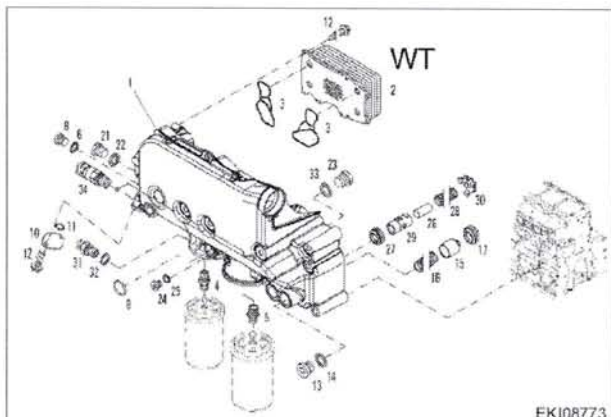

EKI08773

1002722

Fig. 3.

V = pre-heater (coolant) (optional)



On right side of the engine, on the engine oil cooler

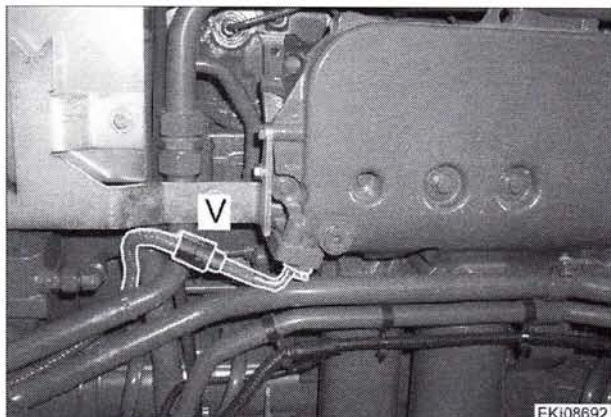

EKI08692

1002727

Fig. 4.

Socket for the pre-heater (coolant)



At the left entrance step

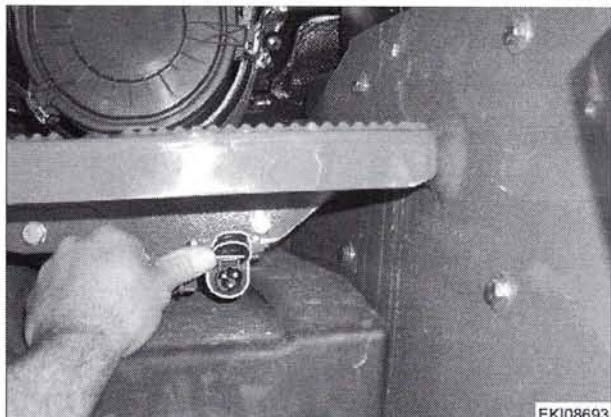

EKI08693

1002728

Fig. 5.

Y - injector (injector valve)

The injectors are water-cooled
The bush is sealed off from the cylinder head by an O-ring.

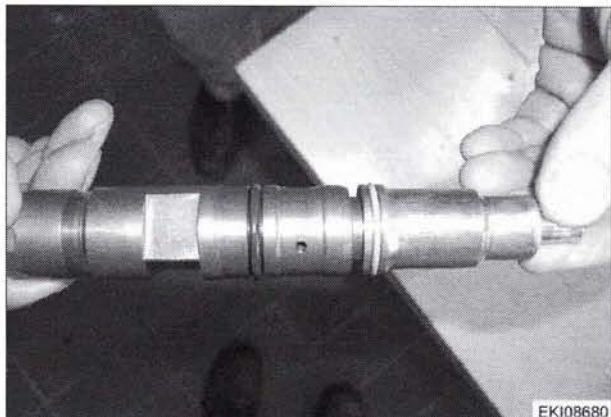

EKI08680

1002724

Fig. 6.

919 .. 0101-1000
919 .. 1001-
922 .. 0101-1000
922 .. 1001-
925 .. 0101-1000

925 .. 1001-
928 .. 0101-1000
928 .. 1001-
931 .. 0101-1000
931 .. 1001-

934 .. 0101-1000
934 .. 1001-

The bush is caulked (rolled) against the cylinder (combustion chamber) (arrow)

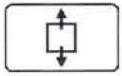

Remove the cylinder head

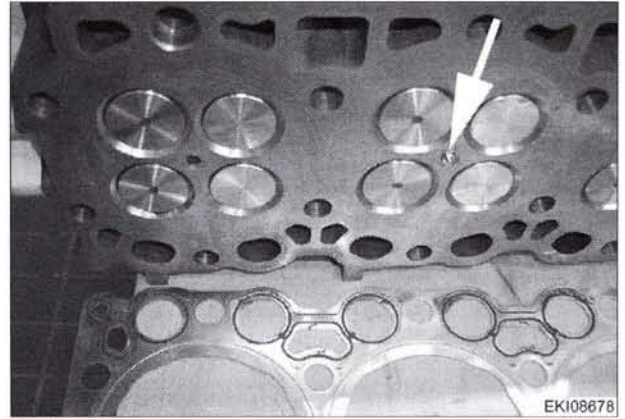

EKI08678
1002729

Fig. 7.

The cylinder liner is sealed off from the crankcase by two O-rings



EKI08682
1002730

Fig. 8.

Upper guidance and sealing of the cylinder liner with a conical guide



EKI08681
1002732

Fig. 9.

Water ducts in the crankcase

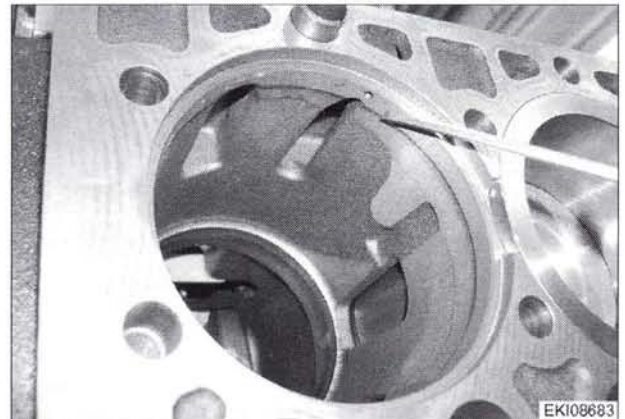

EKI08683
1002731

Fig. 10.

Therm. = thermostat



At the front of the engine

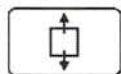

Remove the thermostat housing

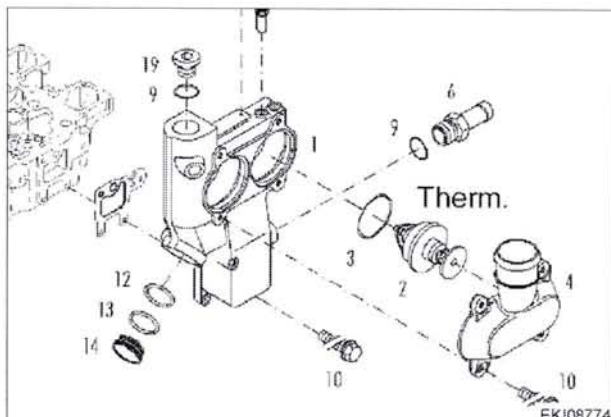

Fig. 11.

EKI08774
1002723

Water cooler with drain plug



On left side of engine.

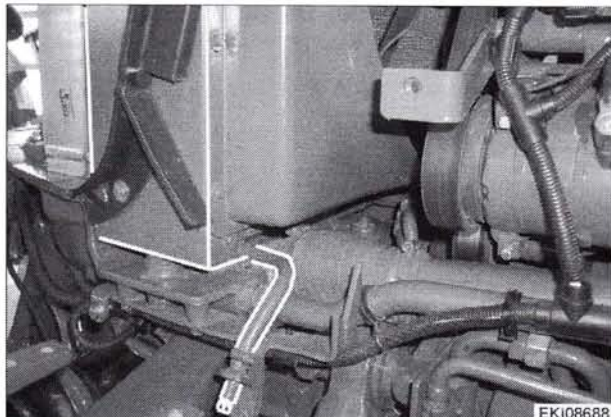

Fig. 12.

EKI08688
1002726

B089 water temperature sensor



At front of the engine, on the thermostat housing

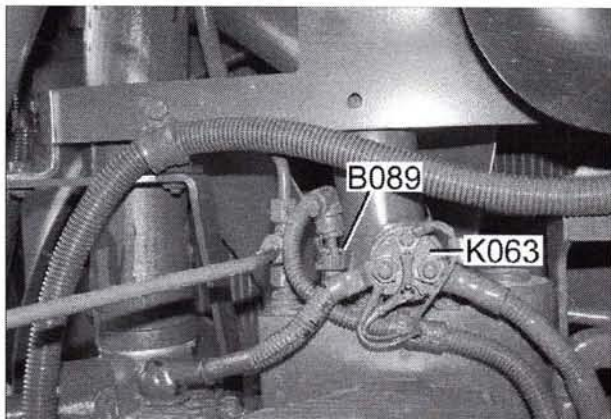

Fig. 13.

1001088

Cooler cover (K)
Expansion tank (T)
S034 coolant level sensor



At top in engine compartment



WARNING: Do not open the cooler cover unless the engine is cold!



Fig. 14.

1001131

919 .. 0101-1000	925 .. 1001-	934 .. 0101-1000
919 .. 1001-	928 .. 0101-1000	934 .. 1001-
922 .. 0101-1000	928 .. 1001-	
922 .. 1001-	931 .. 0101-1000	
925 .. 0101-1000	931 .. 1001-	

A053 air conditioning unit (heater stepper motor and heat exchanger)



Installed under the cab

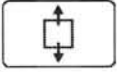

Open the service hatch in the cab floor

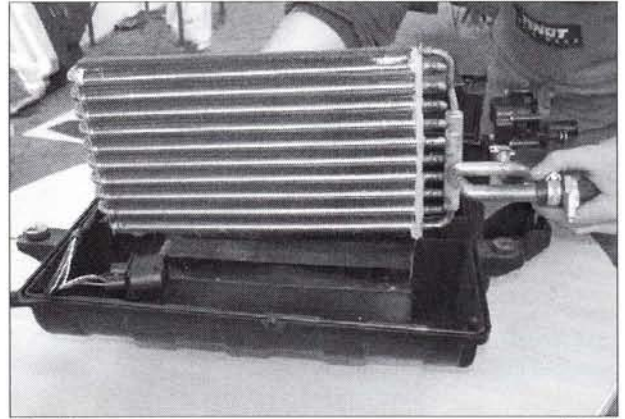

Fig. 15.

1001501

Exhaust gas recirculation (AGR)

The recirculated gas is water-cooled



On left side of engine.

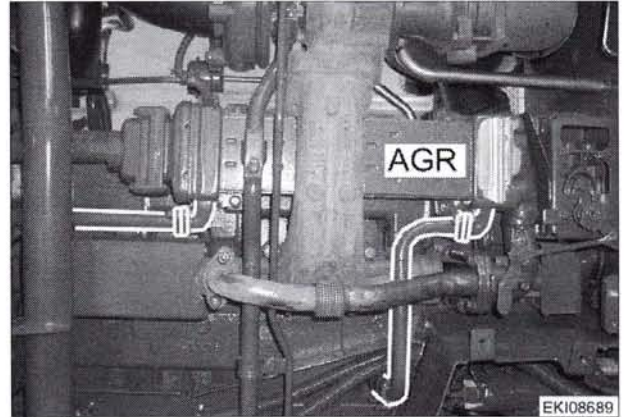

Fig. 16.

EKI08689

1002725

2 B077 electrical viscous fan

Instead of a bi-metal viscous coupling, the FENDTD 900 COM III series has an electrical viscous fan installed. The **B077** - Engine fan (speed sensor/magnetic clutch) is controlled via the **A051** - ECU, engine control unit (EDC 7). and should maintain the coolant temperature at approx. 95°C. The coolant temperature is the main controlled value.

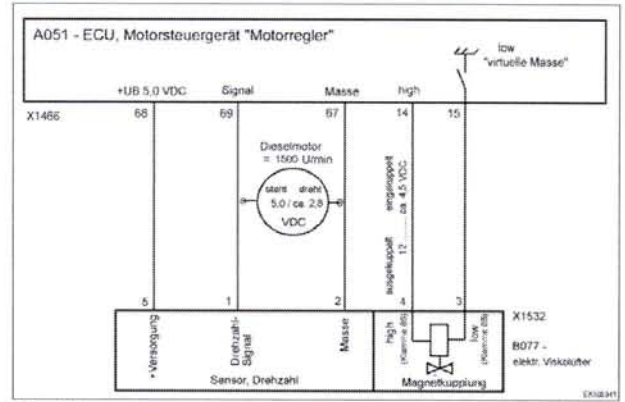

Fig. 17.

1002035

The electrical viscous fan can also be controlled via the transmission oil temperature.

The **B009** - Discharge temperature sensor transmits the transmission oil temperature to the **A050** - ECU, basic control unit. The **A050** - ECU, basic control unit transmits the temperature via the G-bus to the **A051** - ECU, engine control unit (EDC 7). and can thus control the **B077** - Engine fan (speed sensor/magnetic clutch).

The electr. viscous fan can also be controlled via the hydraulic oil temperature.

The **B013** - Sensor, hydraulic oil temperature transmits the hydraulic oil temperature to the **A007** - Instrument panel. Transmission to the **A050** - ECU, basic control unit occurs via K-bus. The **A050** - ECU, basic control unit transmits the temperature via the G-bus to the **A051** - ECU, engine control unit (EDC 7). and can thus control the **B077** - Engine fan (speed sensor/magnetic clutch).

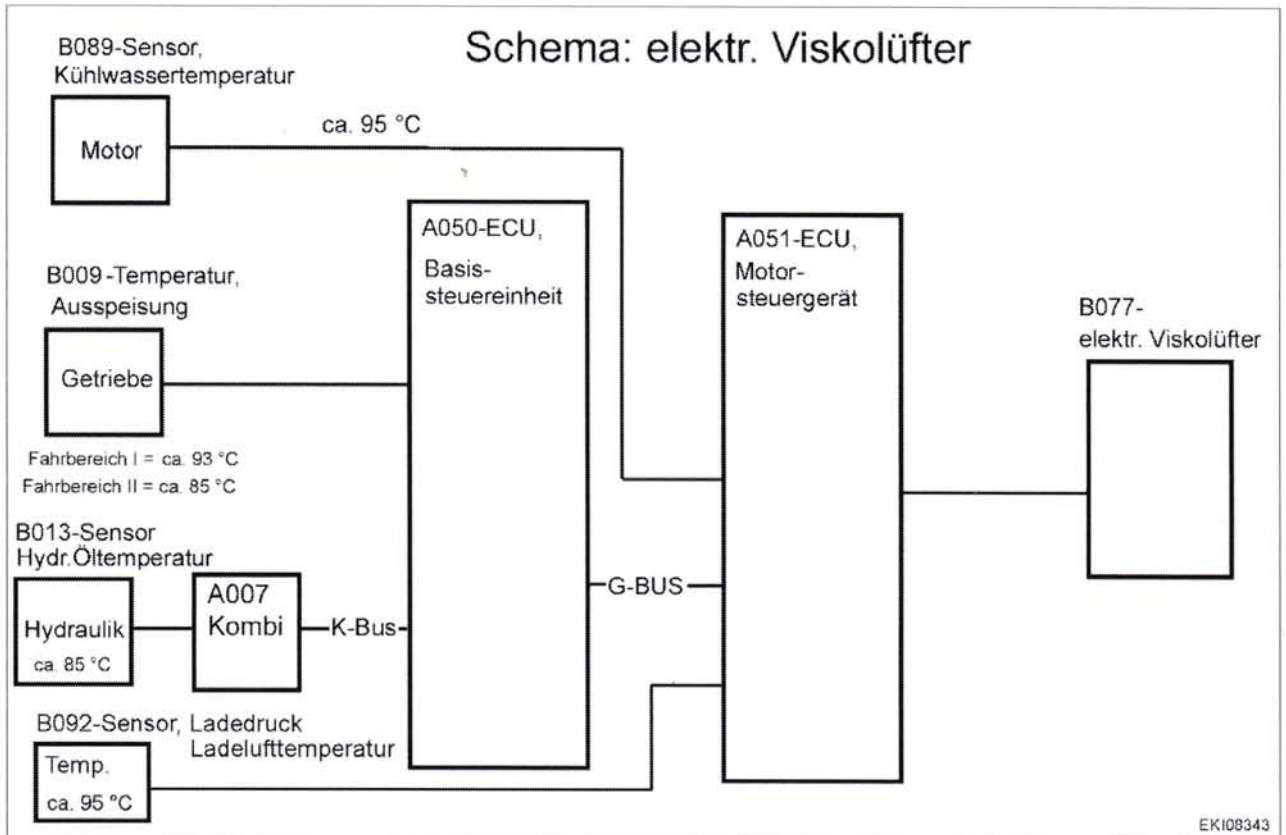

Fig. 18.

EK108343

1002034

Connecting the B077 electr. viscous fan

Unplugging the X1532 separation point causes the viscous fan clutch to become fully engaged.

The fan belt drive ratio is $i = 1.2$ to high speed.

The clutch is hydraulically calibrated so that a residual slip of about 5% remains even when the clutch is fully engaged.

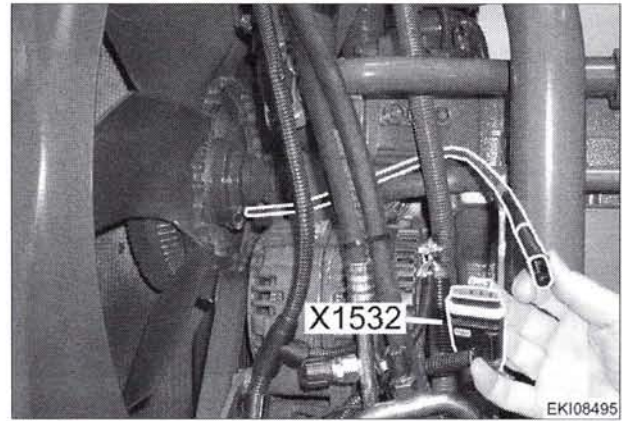

Fig. 19.

EKI08495
1002039

Unplug the X1532 separation point and test the speed of the viscous fan with a tachometer			
Engine speed (rpm)	Fan speed (rpm)		
1500 rpm	Approx. 1710 rpm		
1700 rpm	Approx. 1938 rpm		
1900 rpm	Approx. 2166 rpm		
2100 rpm	Approx. 2394 rpm		
2300 rpm	Approx. 2622 rpm		

Designation	Sensor	Condition for engagement	Note
Transmission	B009 discharge temperature sensor	In travel range I (field): approx. 93 °C (approx. 54 ohms) In travel range II (road): approx. 85 °C (approx. 70 ohms)	If the temperature limit is reached, the A051 ECU, engine control unit engages the B077 electr. viscous fan. The B077 electr. viscous fan is not controlled for the transmission oil temperature.
Working and steering hydraulics	B013 hydraulic oil temperature sensor	approx. 85 °C (approx. 240 ohms)	If the temperature limit is reached, the A051 ECU, engine control unit engages the B077 electr. viscous fan. The B077 electronic viscous fan is not controlled for the hydraulic oil temperature.

Designation	Sensor	Condition for engagement	Note
Diesel engine	B089 coolant temperature sensor	approx. 95 °C (approx. 200 ohms)	If the temperature limit is reached, the A051 ECU, engine control unit engages the B077 electr. viscous fan. The coolant temperature is limited to approx. 95°C by means of the B077 electr. viscous fan
	B092 boost pressure/charge air temperature sensor	approx. 95 °C (approx. 210 ohms)	If the temperature limit is reached, the A051 ECU, engine control unit engages the B077 electr. viscous fan. The B077 electr. viscous fan is not controlled for the charge air temperature

NOTE: see 573

G Repair

1	Removing radiators individually	19
2	Fitting radiators individually	25
3	Removing the cooler assembly	31
4	Fitting cooler assembly	36

1 Removing radiators individually

NOTE: This section explains how to remove all radiators. It may not be necessary to carry out all the steps, depending on which radiator is causing the problem.

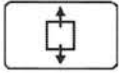

Drain the coolant.

NOTE: Only if the water cooler is being removed!

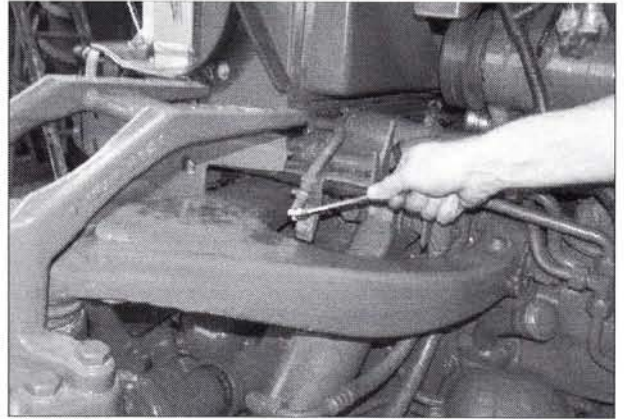
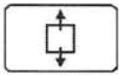

Fig. 1.

1001470



Loosen plugs (arrows) on the left side and drain the oil

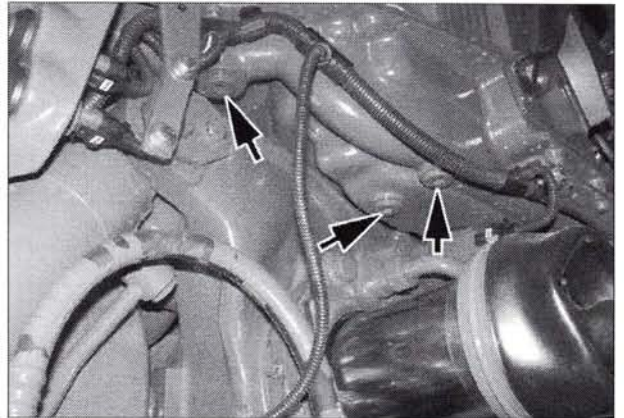
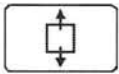

Fig. 2.

1003256



Loosen plugs (arrows) on the right side and drain the oil

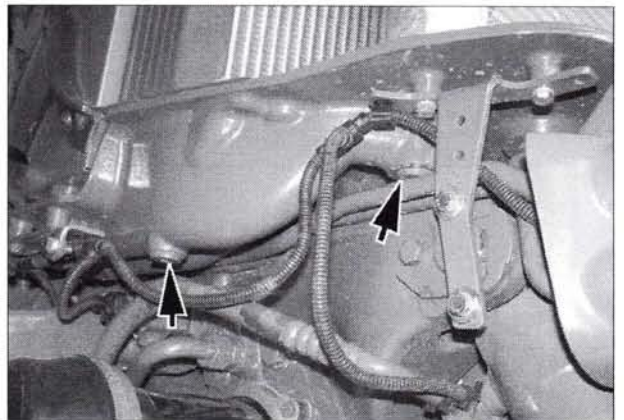
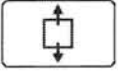

Fig. 3.

1003257



Remove the condenser bracket.

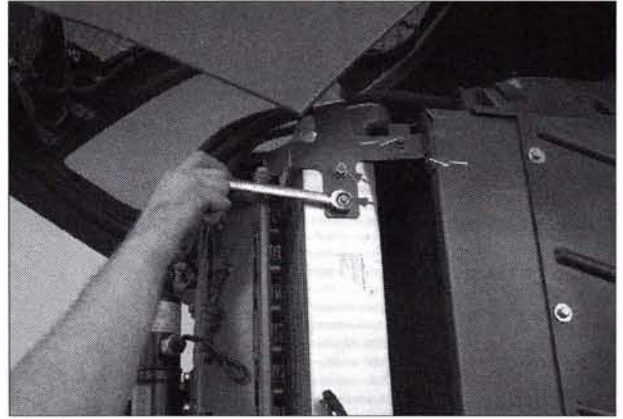
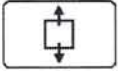

Fig. 4.

1001418



Remove the protective cover from the radiator.

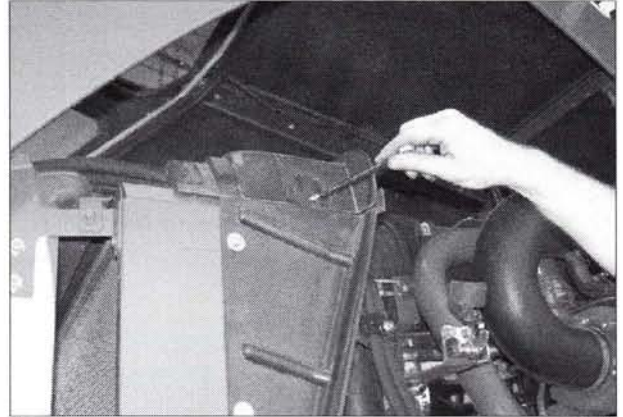
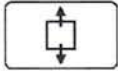

Fig. 5.

1001419



Remove clamps and retaining brackets from the coolant hoses.



Fig. 6.

1001420

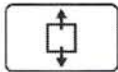

Attach condenser to the engine

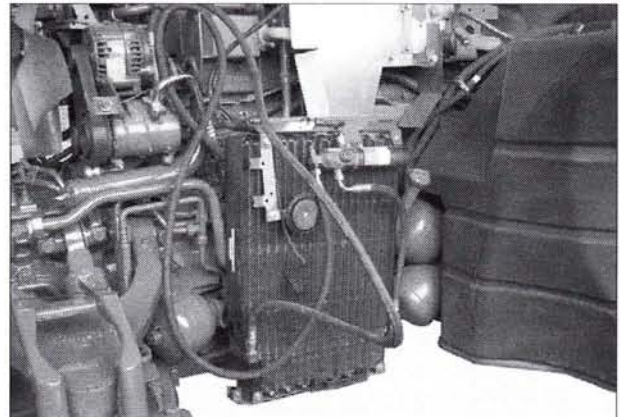
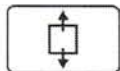

Fig. 7.

1003298



Loosen clamp and pull out air hose



Fig. 8.

1003266

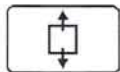

Loosen clamp and pull out coolant hose

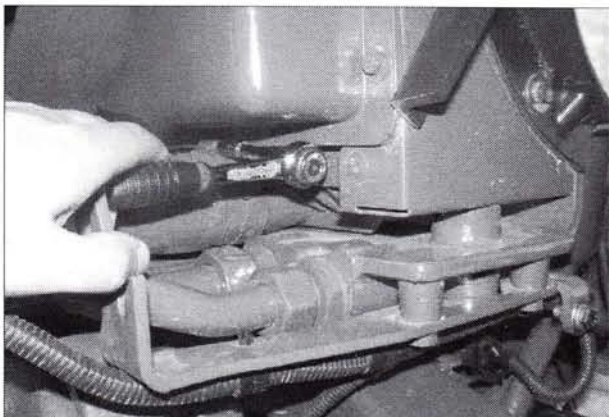
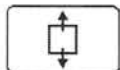

Fig. 9.

1003267



Disconnect hydraulic line from the transmission oil cooler

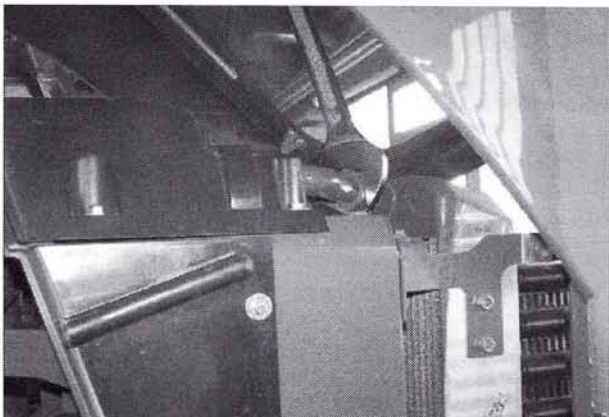
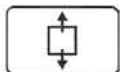

Fig. 10.

1003268



Loosen clamp and remove charge air hose



Fig. 11.

1003211

919 .. 0101-1000
 919 .. 1001-
 922 .. 0101-1000
 922 .. 1001-
 925 .. 0101-1000

925 .. 1001-
 928 .. 0101-1000
 928 .. 1001-
 931 .. 0101-1000
 931 .. 1001-

934 .. 0101-1000
 934 .. 1001-

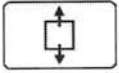

Loosen clamp and remove coolant hose

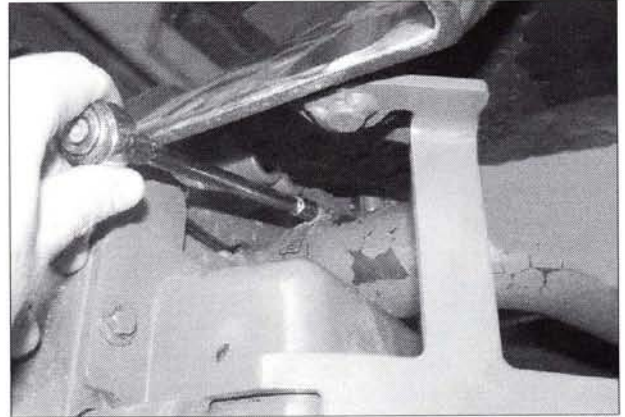
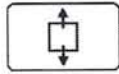

Fig. 12.

1003322



Remove screws on the hydraulic oil cooler

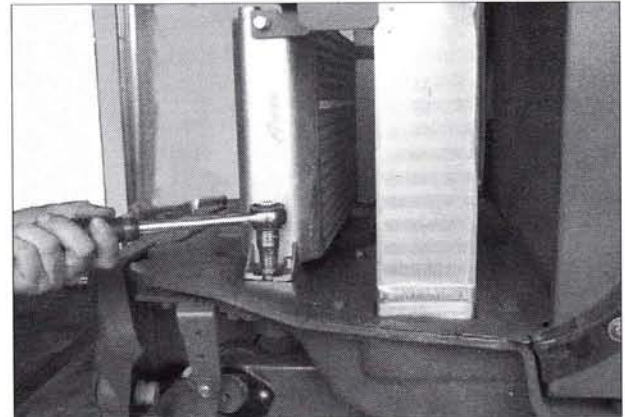
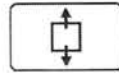

Fig. 13.

1003212



Remove the hydraulic oil cooler

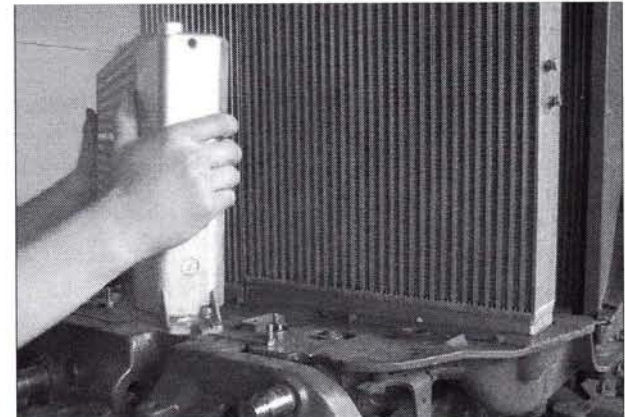
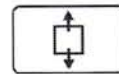

Fig. 14.

1003213



Remove the water cooler bracket on the intercooler

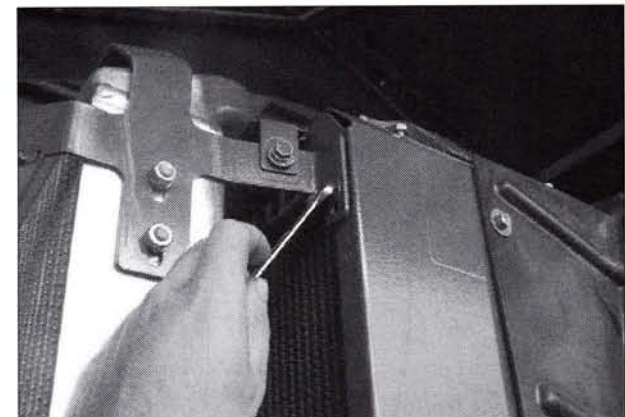
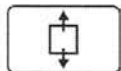

Fig. 15.

1003258



Remove the cover panel from the charge air transmission oil cooler



Fig. 16.

1003259

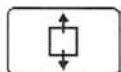

Remove the retaining bolts on the charge air transmission oil cooler



Fig. 17.

1003260

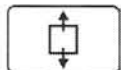

Remove the charge air transmission oil cooler

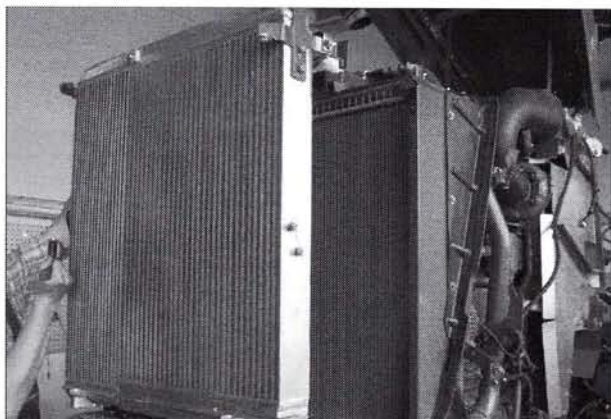
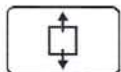

Fig. 18.

1003261



Remove the intake air duct



Fig. 19.

1003217

919 .. 0101-1000
 919 .. 1001-
 922 .. 0101-1000
 922 .. 1001-
 925 .. 0101-1000

925 .. 1001-
 928 .. 0101-1000
 928 .. 1001-
 931 .. 0101-1000
 931 .. 1001-

934 .. 0101-1000
 934 .. 1001-

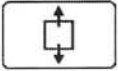

Remove the ventilator cowl bolts and slide the cowl back

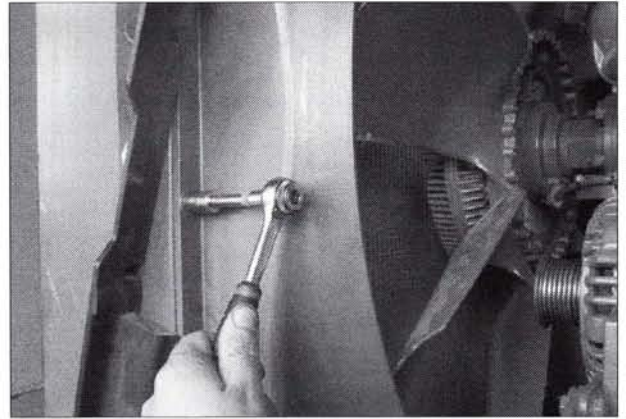
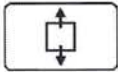

Fig. 20.

I003219



Remove the bolts on the water cooler retaining bracket

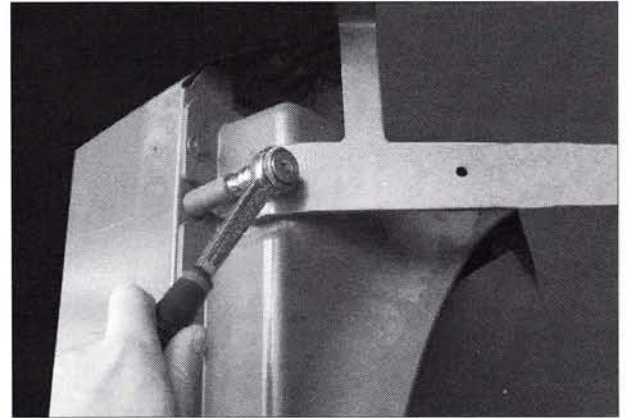
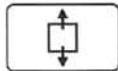

Fig. 21.

I003323



Remove the retaining bolts on the water cooler

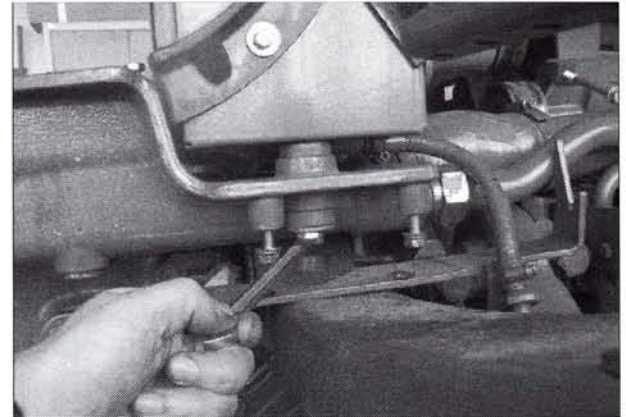
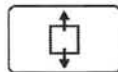

Fig. 22.

I003262



Remove the water cooler

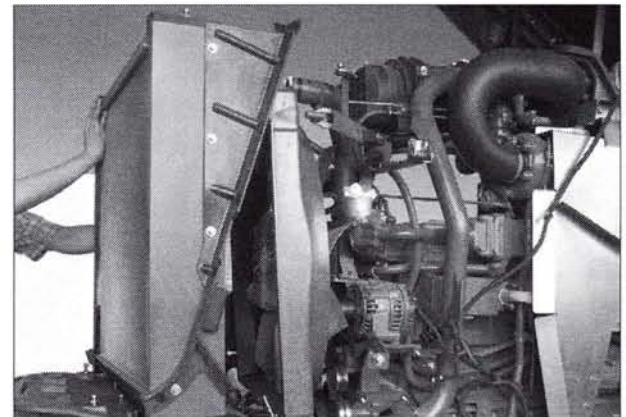
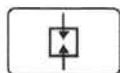

Fig. 23.

I003263

2 Fitting radiators individually



Use a small amount of grease to seat the O-rings



Fig. 24.

1003320

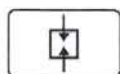

Fit the water cooler

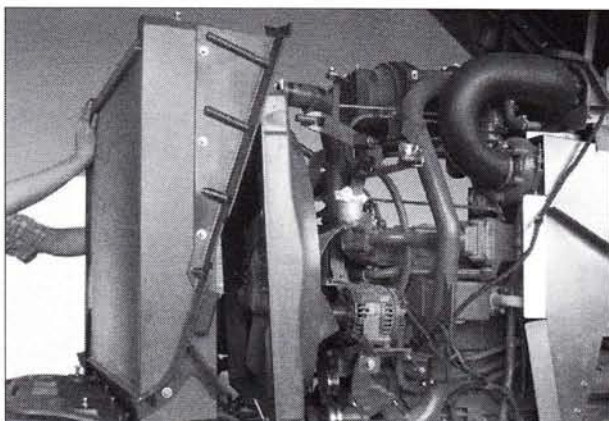
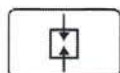

Fig. 25.

1003263



Fit the water cooler retaining bolts and bearing

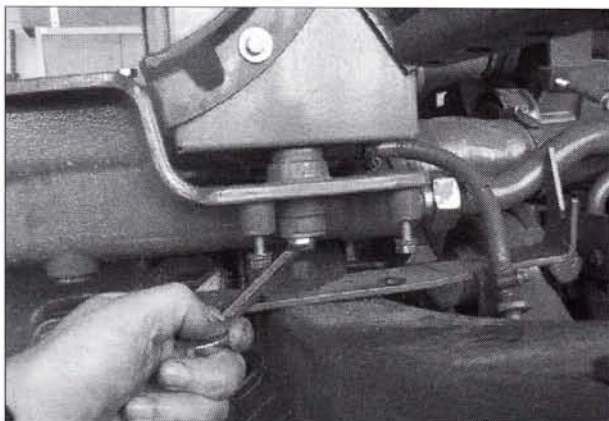
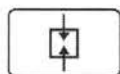

Fig. 26.

1003262



Slide the ventilator cowl forwards and fit the cowl bolts

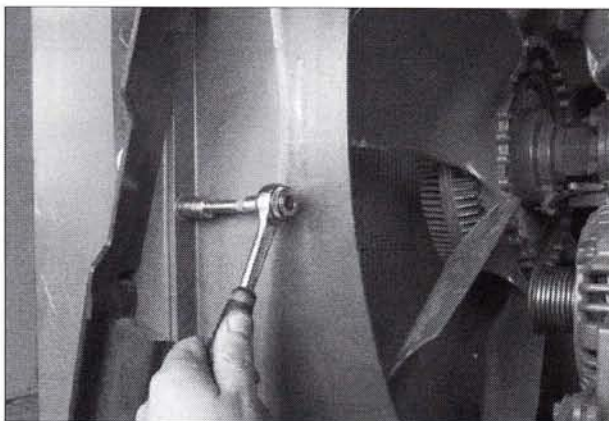

Fig. 27.

1003219

919 .. 0101-1000
919 .. 1001-
922 .. 0101-1000
922 .. 1001-
925 .. 0101-1000

925 .. 1001-
928 .. 0101-1000
928 .. 1001-
931 .. 0101-1000
931 .. 1001-

934 .. 0101-1000
934 .. 1001-

T001174
Version 1
07-11-2007

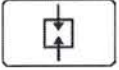

Fit the water cooler on the retaining bracket

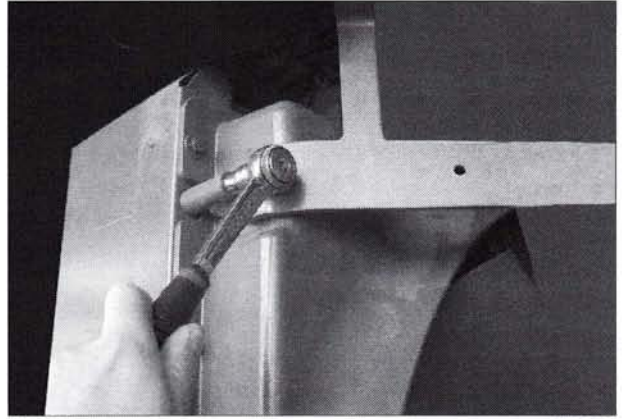
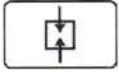

Fig. 28.

1003323



Fit the intake air duct

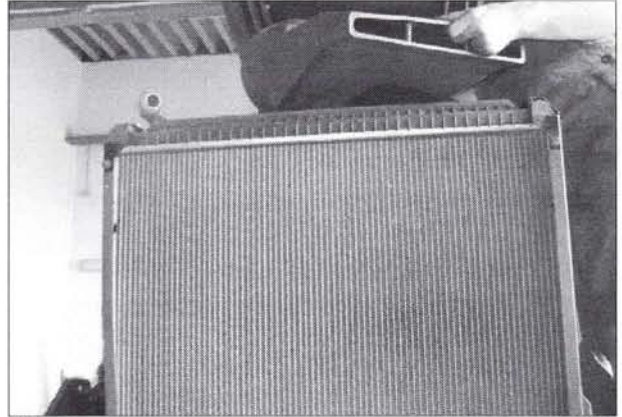
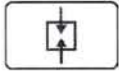

Fig. 29.

1003217



Fit the charge air transmission oil cooler

NOTE: Take care not to damage the O-rings!

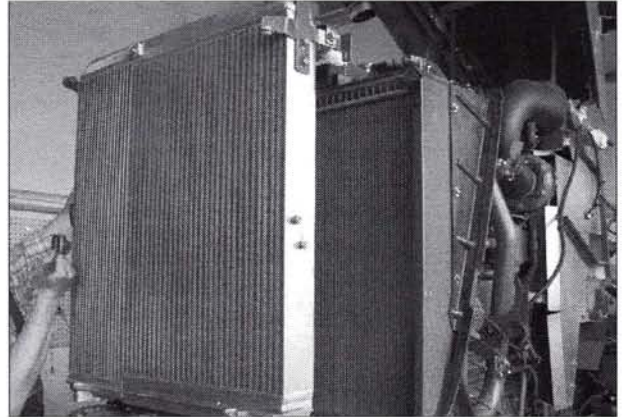
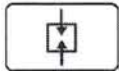

Fig. 30.

1003261



Fit the retaining bolts on the charge air transmission oil cooler



Fig. 31.

1003260

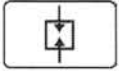

Fit the cover panel bolts on the charge air transmission oil cooler

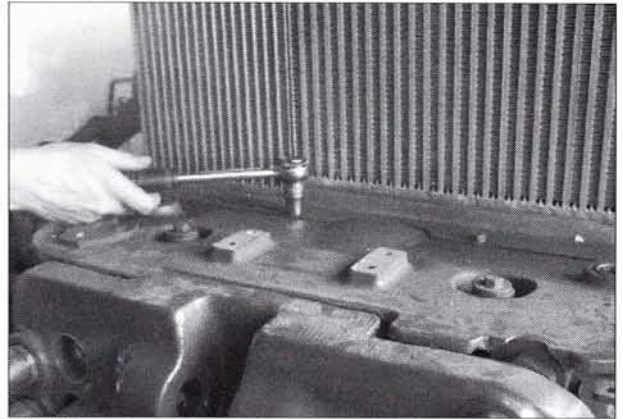
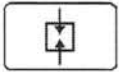

Fig. 32.

1003259



Fit the water cooler bracket on the intercooler

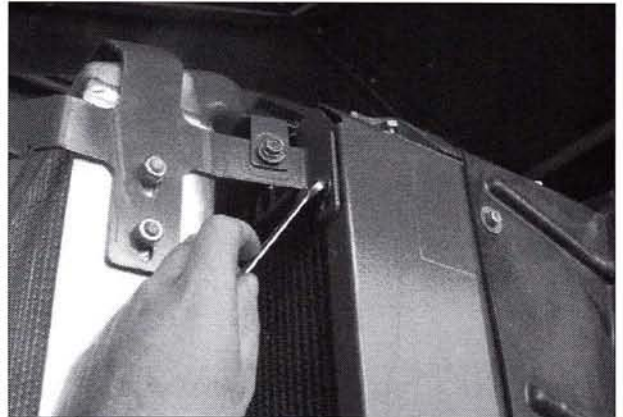
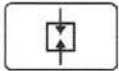

Fig. 33.

1003258



Fit the hydraulic oil cooler

NOTE: Take care not to damage the O-rings!

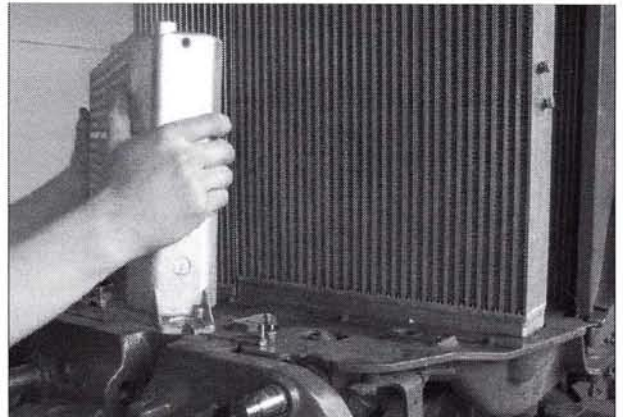
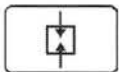

Fig. 34.

1003213



Fit the bolts on the hydraulic oil cooler



Fig. 35.

1003212

919 .. 0101-1000
919 .. 1001-
922 .. 0101-1000
922 .. 1001-
925 .. 0101-1000

925 .. 1001-
928 .. 0101-1000
928 .. 1001-
931 .. 0101-1000
931 .. 1001-

934 .. 0101-1000
934 .. 1001-

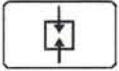

Fit the charge air hose and tighten the clamp

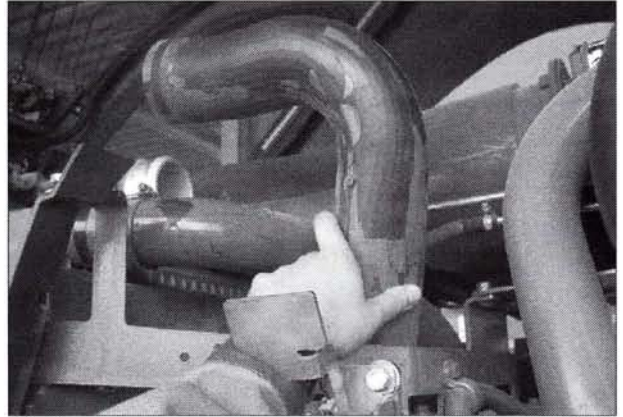
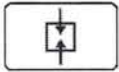

Fig. 36.

1003211



Fit the coolant hose and tighten the clamp



Fig. 37.

1003322

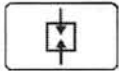

Fit the hydraulic line on the transmission oil cooler

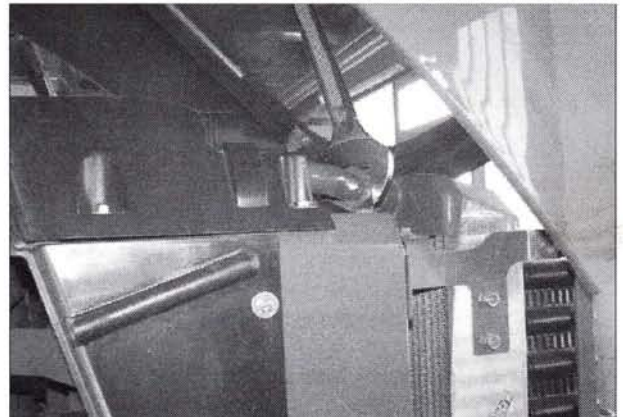
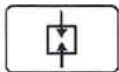

Fig. 38.

1003268



Fit the coolant hose and tighten the clamp

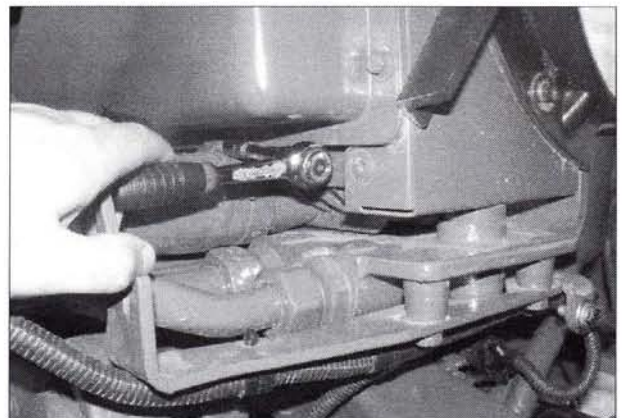
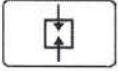

Fig. 39.

1003267



Fit the air hose and tighten the clamp



Fig. 40.

1003266

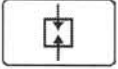

Place condenser in position and fit the bracket

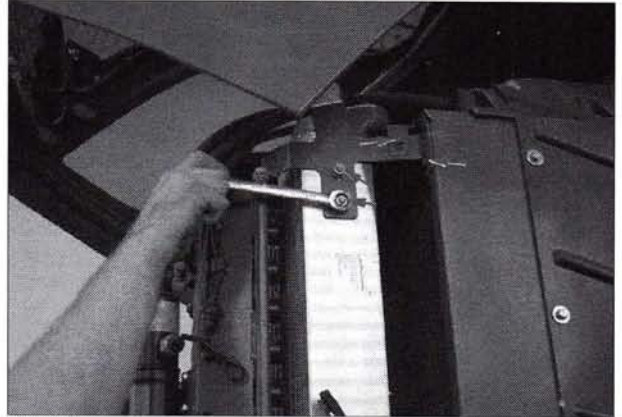
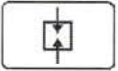

Fig. 41.

1001418



Fit the protective cover on the radiator.

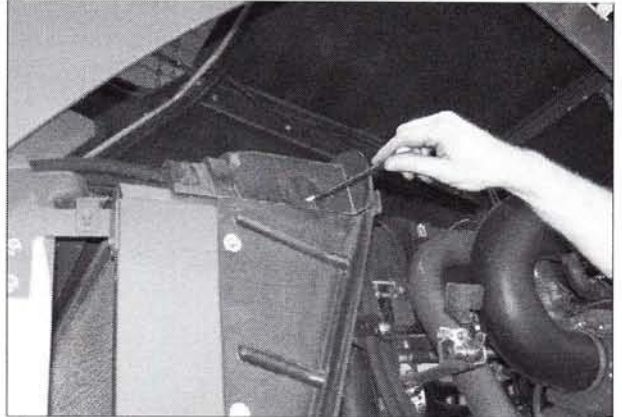
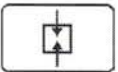

Fig. 42.

1001419



Fit clamps and retaining brackets on the coolant hoses.



Fig. 43.

1001420

919 .. 0101-1000
 919 .. 1001-
 922 .. 0101-1000
 922 .. 1001-
 925 .. 0101-1000

925 .. 1001-
 928 .. 0101-1000
 928 .. 1001-
 931 .. 0101-1000
 931 .. 1001-

934 .. 0101-1000
 934 .. 1001-

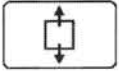

Fit all screw plugs that were removed on the left and right sides

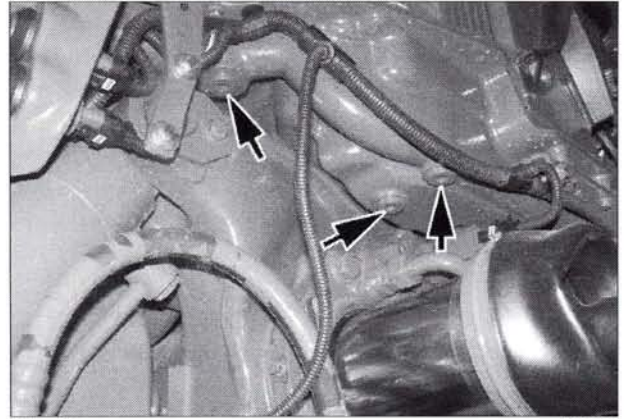
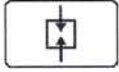

Fig. 44.

1003256



Fit screw plug and fill with coolant

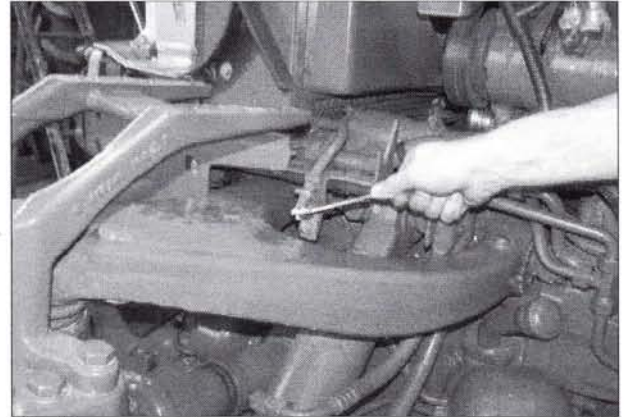
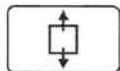

Fig. 45.

1001470

3 Removing the cooler assembly



Drain the coolant.

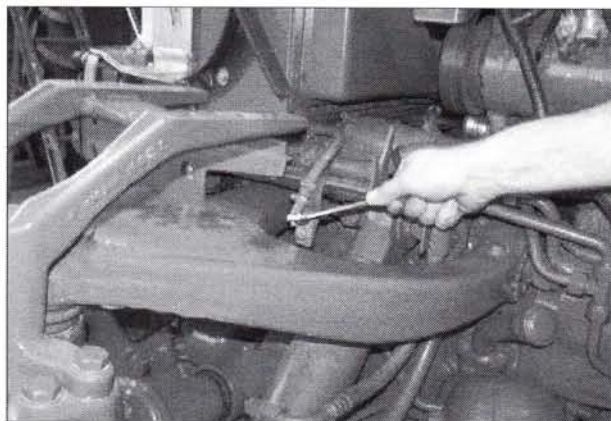
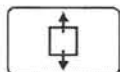

Fig. 46.

1001470



Loosen plugs (arrows) on the left side and drain the oil

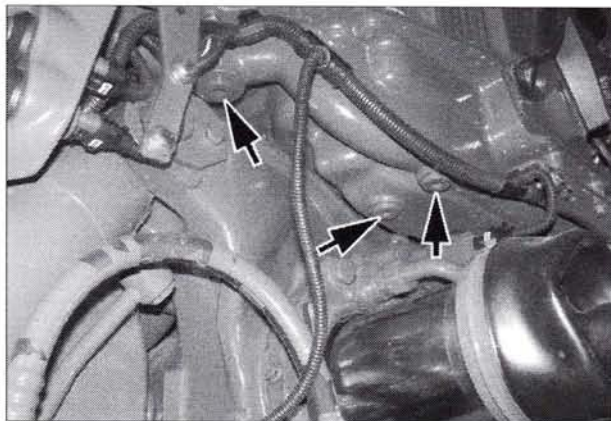
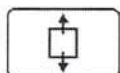

Fig. 47.

1003256



Loosen plugs (arrows) on the right side and drain the oil

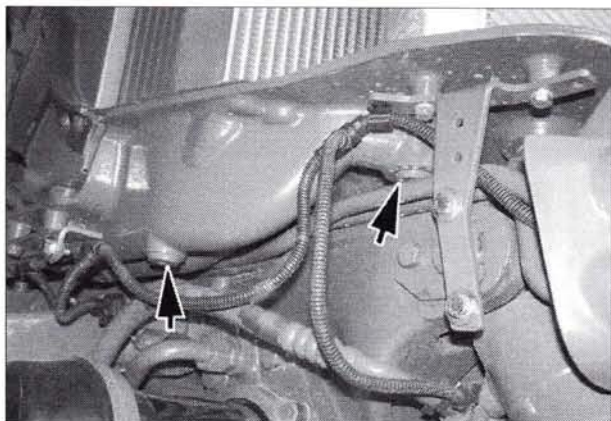
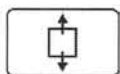

Fig. 48.

1003257



Remove the condenser bracket.



Fig. 49.

1001418

919 .. 0101-1000
919 .. 1001-
922 .. 0101-1000
922 .. 1001-
925 .. 0101-1000

925 .. 1001-
928 .. 0101-1000
928 .. 1001-
931 .. 0101-1000
931 .. 1001-

934 .. 0101-1000
934 .. 1001-

T001190
Version 1
07-11-2007

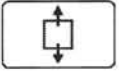

Remove the protective cover from the radiator.

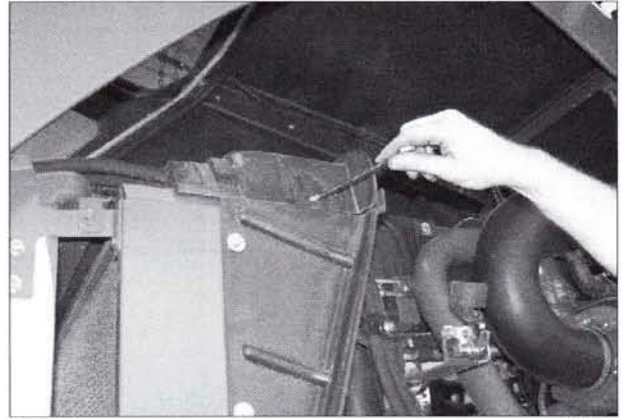
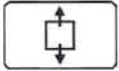

Fig. 50.

1001419



Remove clamps and retaining brackets from the coolant hoses.



Fig. 51.

1001420

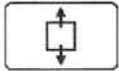

Attach condenser to the engine

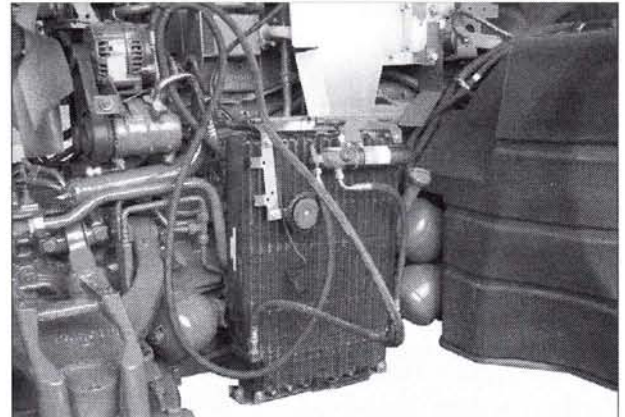
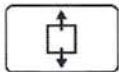

Fig. 52.

1003298



Loosen clamp and pull out air hose

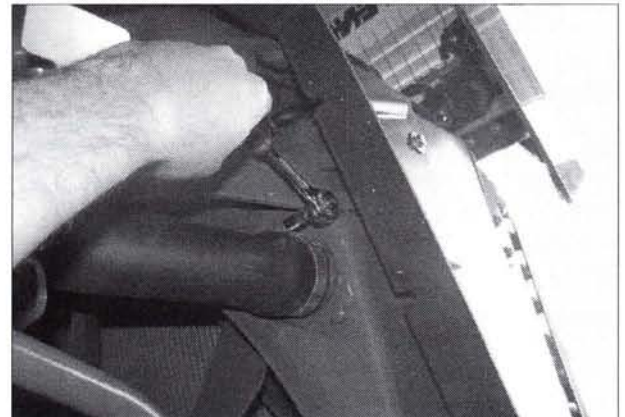
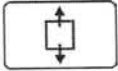

Fig. 53.

1003266



Loosen clamp and pull out coolant hose

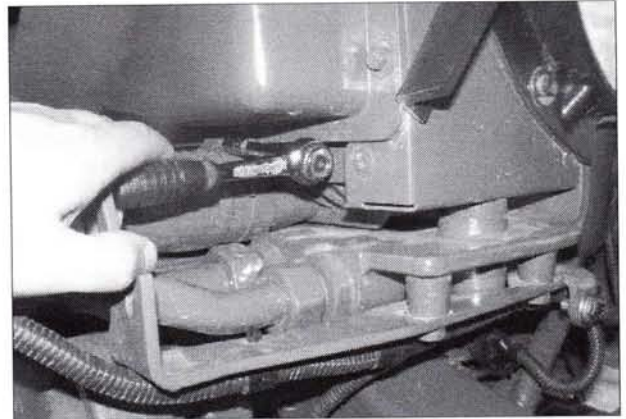
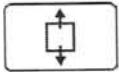

Fig. 54.

I003267



Disconnect hydraulic line from the transmission oil cooler

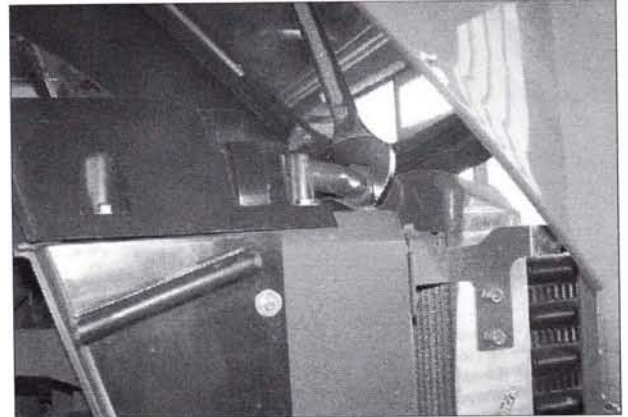
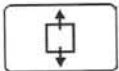

Fig. 55.

I003268



Disconnect both hydraulic lines from the cooler pan

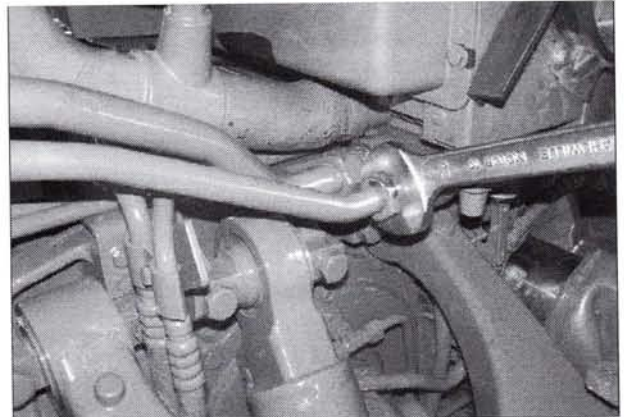
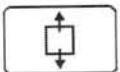

Fig. 56.

I003417



Loosen clamp and remove charge air hose



Fig. 57.

I003211

919 .. 0101-1000
 919 .. 1001-
 922 .. 0101-1000
 922 .. 1001-
 925 .. 0101-1000

925 .. 1001-
 928 .. 0101-1000
 928 .. 1001-
 931 .. 0101-1000
 931 .. 1001-

934 .. 0101-1000
 934 .. 1001-

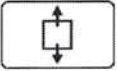

Loosen clamp and remove coolant hose

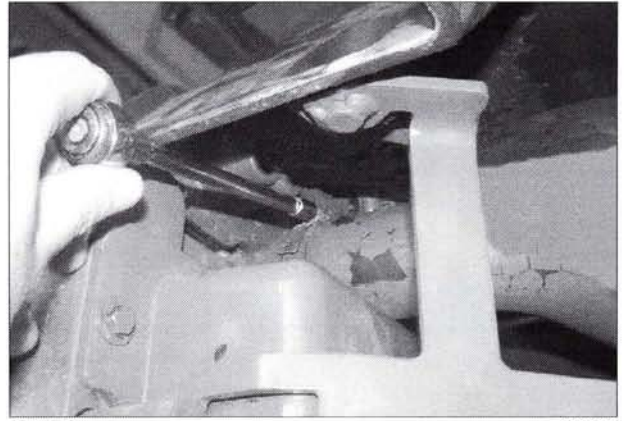
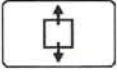

Fig. 58.

1003322



Disconnect the hydraulic line from the front return flow

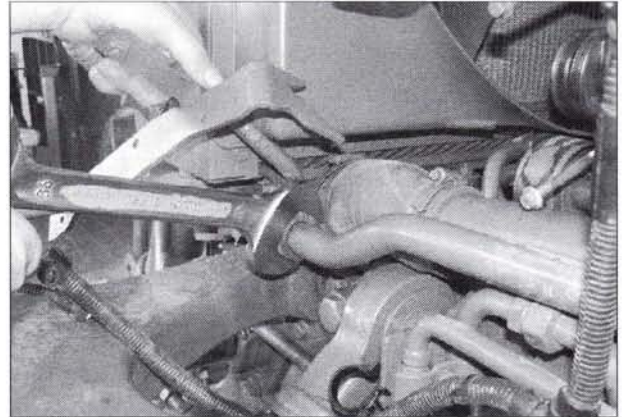
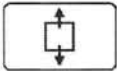

Fig. 59.

1003202



Loosen clamps and remove bottom charge air line

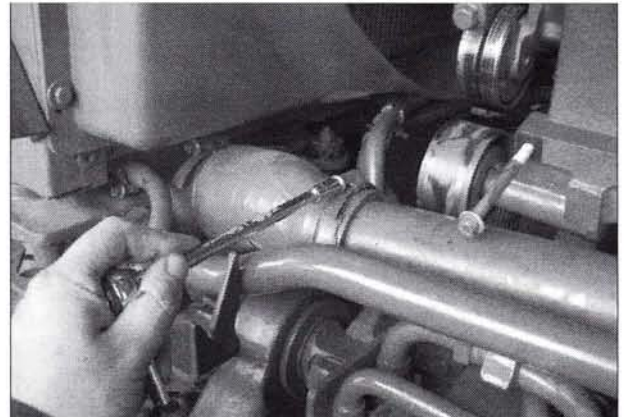
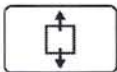

Fig. 60.

1003209



Remove the intake air duct

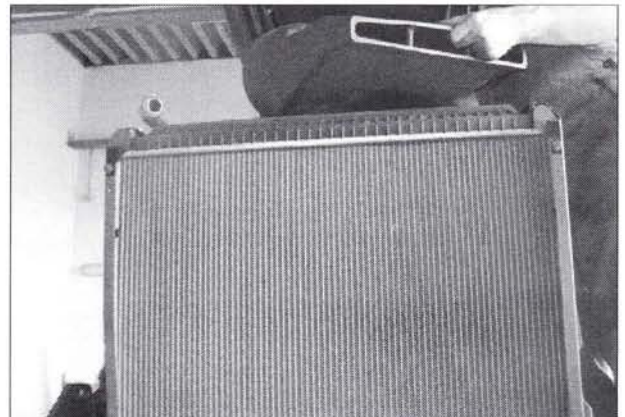
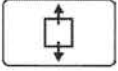

Fig. 61.

1003217



Remove the ventilator cowl bolts and slide the cowl back



Fig. 62.

I003219

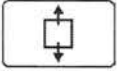

Remove the bolts on the water cooler retaining bracket

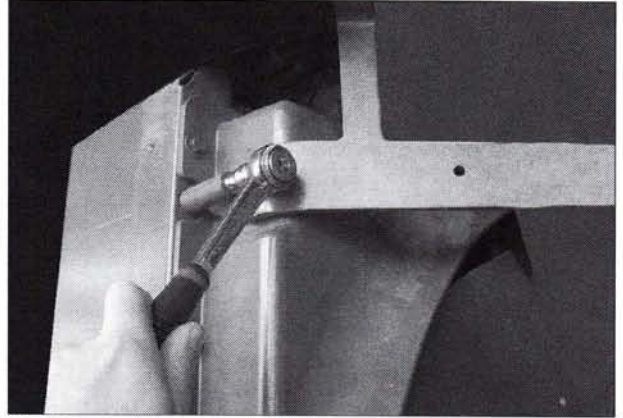
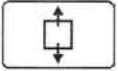

Fig. 63.

I003323



Remove nuts and bearings from the pan



Fig. 64.

I003220

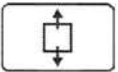

Carefully lift and remove the cooler assembly

NOTE: Ensure there is sufficient clearance between all components.

⚠ DANGER: Do not walk or stand under suspended loads!

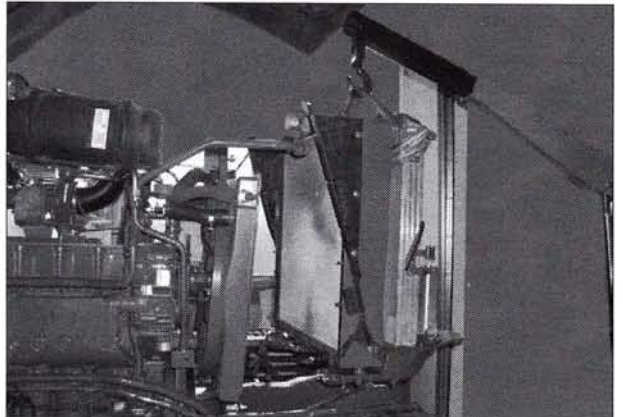
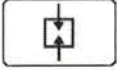

Fig. 65.

I003418

4 Fitting cooler assembly



Carefully lift the cooler assembly and raise it into position

NOTE: Ensure there is sufficient clearance between all components.



DANGER: Do not walk or stand under suspended loads!

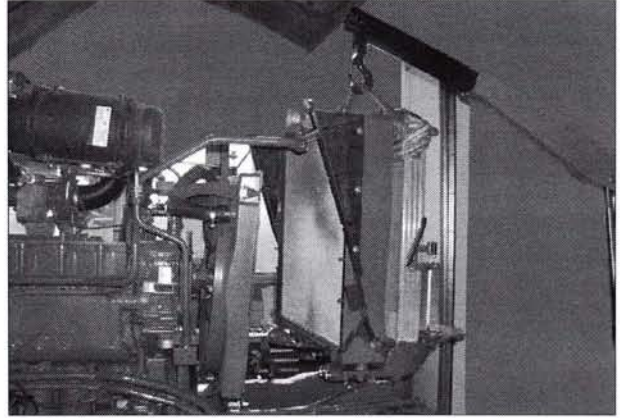
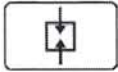

Fig. 66.

1003418



Fit nuts and bearings on the cooler pan



Fig. 67.

1003220

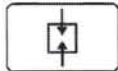

Slide the ventilator cowl forwards and fit the cowl bolts



Fig. 68.

1003219

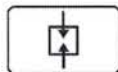

Fit the water cooler on the retaining bracket

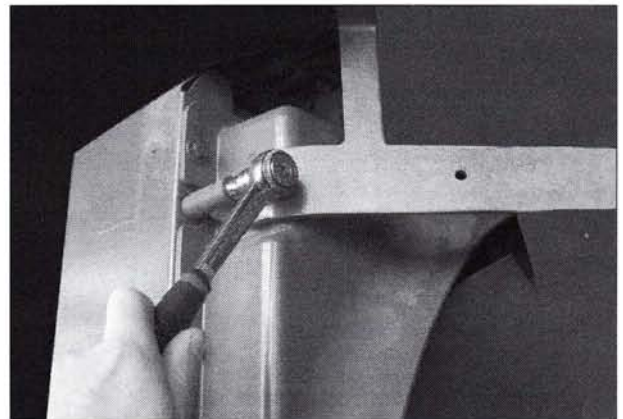
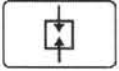

Fig. 69.

1003323



Fit the intake air duct

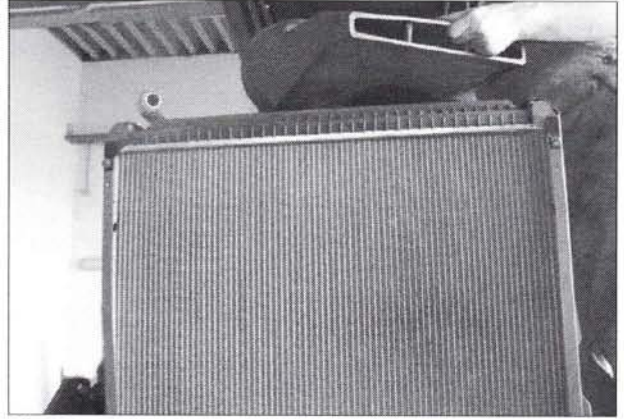
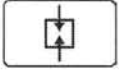

Fig. 70.

1003217



Fit the charge air hose and tighten the clamp



Fig. 71.

1003211

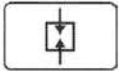

Fit the coolant hose and tighten the clamp,



Fig. 72.

1003322

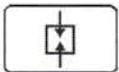

Fit the hydraulic line on the front return flow

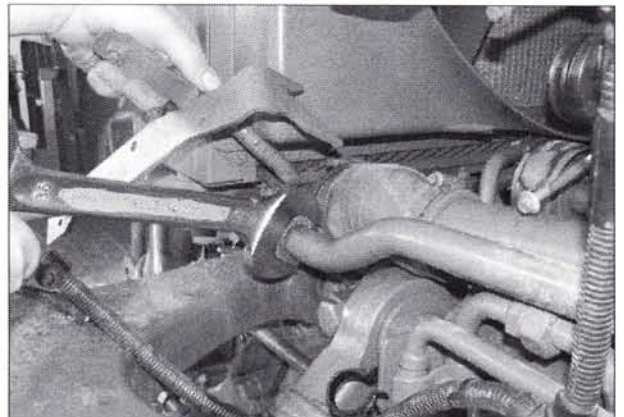

Fig. 73.

1003202

919 .. 0101-1000
919 .. 1001-
922 .. 0101-1000
922 .. 1001-
925 .. 0101-1000

925 .. 1001-
928 .. 0101-1000
928 .. 1001-
931 .. 0101-1000
931 .. 1001-

934 .. 0101-1000
934 .. 1001-

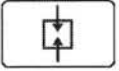

Fit the hydraulic line on the transmission oil cooler



Fig. 74.

1003268

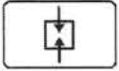

Fit the coolant hose and tighten the clamp

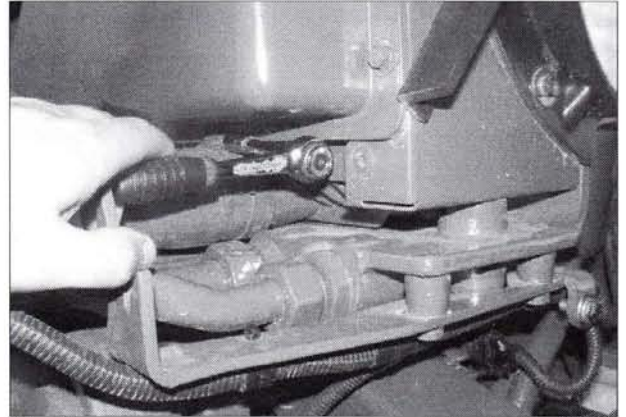
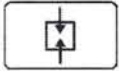

Fig. 75.

1003267



Fit the air hose and tighten the clamp



Fig. 76.

1003266

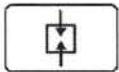

Place condenser in position and fit the bracket

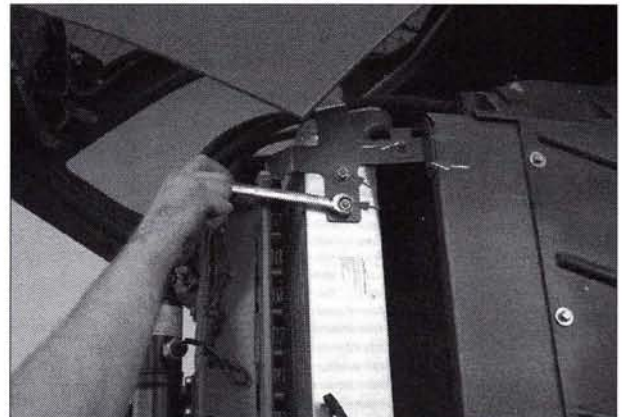
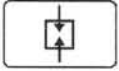

Fig. 77.

1001418



Fit the protective cover on the radiator.

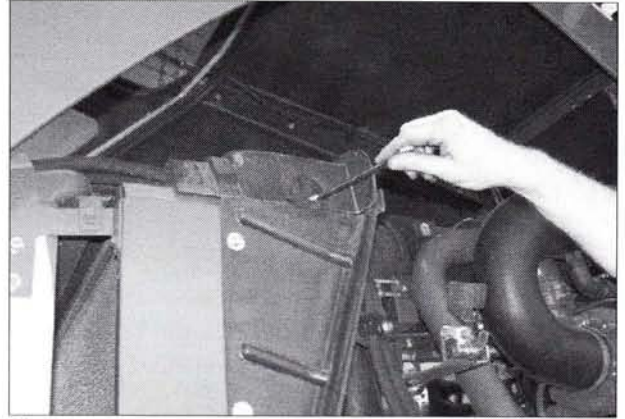
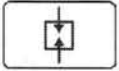

Fig. 78.

I001419



Fit clamps and retaining brackets on the coolant hoses.



Fig. 79.

I001420

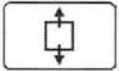

Fit all screw plugs that were removed on the left and right sides

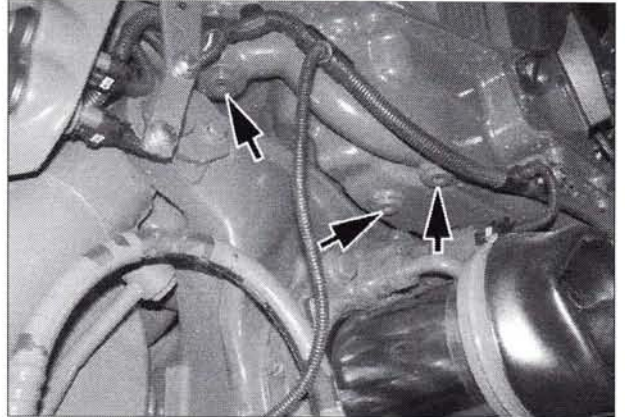
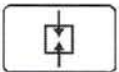

Fig. 80.

I003256



Fit screw plug and fill with coolant

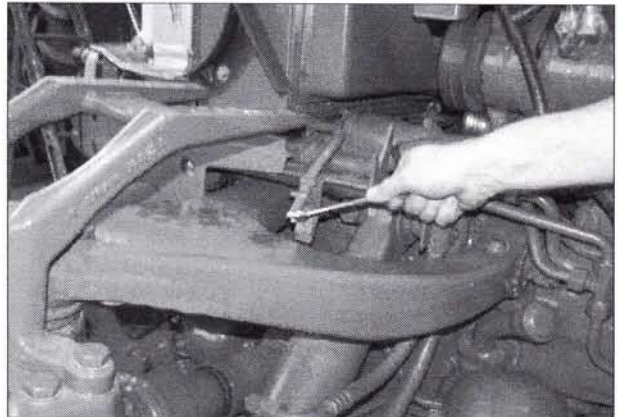

Fig. 81.

I001470

919 .. 0101-1000
 919 .. 1001-
 922 .. 0101-1000
 922 .. 1001-
 925 .. 0101-1000

925 .. 1001-
 928 .. 0101-1000
 928 .. 1001-
 931 .. 0101-1000
 931 .. 1001-

934 .. 0101-1000
 934 .. 1001-

